

PRODUCT INFORMATION PACKET



Model No: C6T17WC63A

Catalog No: 191567.00

..1 1/2HP..1740RPM.56.TEFC.208-230/460V.3PH.60HZ.CONT.40C.1.15SF.C FACE.....WASHGUARD-ALL
STAINLESS.NOT.....

Paint Free



Regal and Leeson are trademarks of Regal Beloit Corporation or one of its affiliated companies.

©2018 Regal Beloit Corporation, All Rights Reserved. MC017097E





Nameplate Specifications

Output HP	1.50 Hp	Output KW	1.1 kW
Frequency	60 Hz	Voltage	208-230/460 V
Current	4.8-4.4/2.2 A	Speed	1750 rpm
Service Factor	1.15	Phase	3
Efficiency	86.5 %	Duty	Continuous
Insulation Class	F	Design Code	B
KVA Code	M	Frame	56C
Enclosure	Totally Enclosed Fan Cooled	Overload Protector	No
Ambient Temperature	40 °C	Drive End Bearing Size	6205
Opp Drive End Bearing Size	6205	UL	Recognized
CSA	Y	CE	Y
IP Code	55		

Technical Specifications

Electrical Type	Squirrel Cage Inverter Rated	Starting Method	Line Or Inverter
Poles	4	Rotation	Reversible
Mounting	Round	Motor Orientation	HORIZONTAL
Drive End Bearing	BALL	Opp Drive End Bearing	BALL
Frame Material	Stainless Steel	Shaft Type	NEMA 56
Overall Length	13.77 in	Frame Length	7.99 in
Shaft Diameter	0.625 in	Shaft Extension	1.88 in
Assembly/Box Mounting	F1/F2 CAPABLE		
Outline Drawing	16992600	Connection Diagram	005010.01

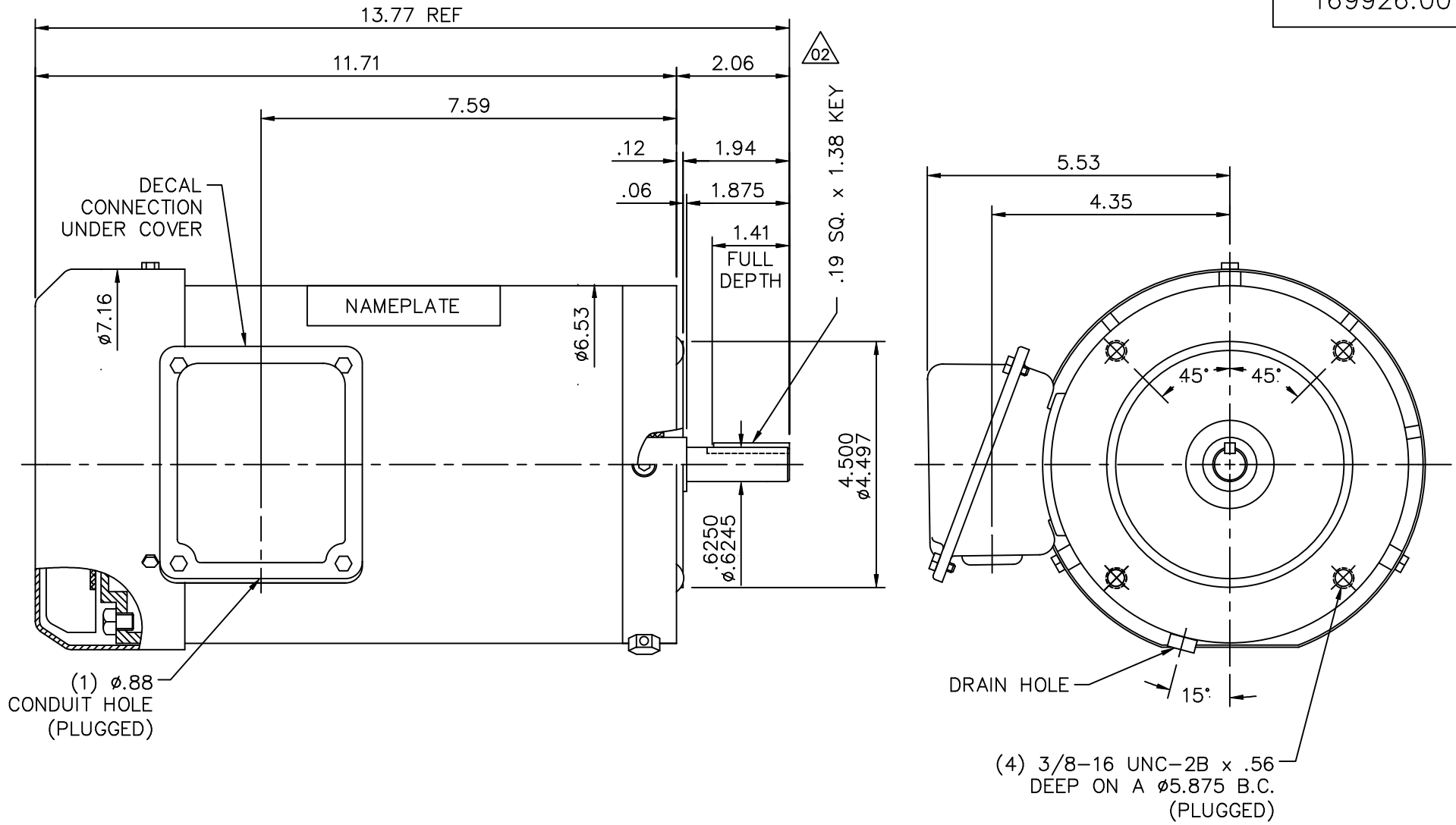

MAXIMUM FACE RUNOUT TO BE .004 T.I.R.
 MAXIMUM PILOT ECCENTRICITY .004 T.I.R.
 PERMISSIBLE SHAFT RUNOUT .002 T.I.R.

GASKETS THROUGHOUT

				TOLERANCES UNLESS SPECIFIED		 ELECTRIC MOTORS GEARMOTORS AND DRIVES	DRAWN
				DEC.	INCHES		MGM
				.X	±.1		04/09/03
				.XX	±.03		RDW
				.XXX	±.005	TITLE	APPD
02	UPDATED SHAFT EXT DIMS	RDW 4/26/04	SW	.XXX	±.005	OUTLINE - 56C FRAME TEFC - "C" FACE	SCALE 3=8
01	CONDUIT HOLE WAS 1/2-14 NPT, DIM .157 WAS .12	SW 10/7/2003	RDW	.XXXX	±.0005	MAT'L.	REF
NO.	REVISION	BY & DATE	CHK	ANG	±1/2'	FINISH	FMF
THIS DRAWING IN DESIGN AND DETAIL IS OUR PROPERTY AND MUST NOT BE USED EXCEPT IN CONNECTION WITH OUR WORK ALL RIGHTS OF DESIGN AND INVENTION ARE RESERVED THIS IS AN ELECTRONICALLY GENERATED DOCUMENT - DO NOT SCALE THIS PRINT				RFP		CAD FILE	16992600
				DIST		SIZE	DRAWING NO.
						A	169926.00
							REV.
							01

005010-01

VIEW FROM OUTSIDE OF MOTOR AT SWITCH END.



VOLTAGE	L1	L2	L3	JOIN & INSULATE
HIGH	T1	T2	T3	(T4,T7) (T5,T8) (T6,T9)
LOW	T1,T7	T2,T8	T3,T9	T4,T5,T6

				TOLERANCES UNLESS SPECIFIED		REGAL ™ Regal Beloit America, Inc.		DRAWN RDW 04/12/02		
				DEC.	INCHES			CHK		
				.X	±.1			APPD		
				.XX	±.01			SCALE 1=1		
				.XXX	±.005	TITLE		REF FIG.2-51		
A	UPDATED TO REGAL LOGO	SAJ 06/26/15	AJY	.XXXX	±.0005	MAT'L.		FMF		
NO.	REVISION	BY & DATE	CHK	ANG	±1/2"	FINISH		PREV		
THIS DRAWING IN DESIGN AND DETAIL IS OUR PROPERTY AND MUST NOT BE USED EXCEPT IN CONNECTION WITH OUR WORK ALL RIGHTS OF DESIGN AND INVENTION ARE RESERVED THIS IS AN ELECTRONICALLY GENERATED DOCUMENT - DO NOT SCALE THIS PRINT				RFP	04/12/02	CAD FILE		SIZE	DRAWING NO.	REV.
				DIST	BRF-NLV	00501001		A	005010-01	A



P.O. BOX 8003
WAUSAU, WI 54401-8003
PH. 715-675-3311

DATA VOLTS: 460

CERTIFICATION DATA SHEET

CONN. DIAGRAM: 005010.01
OUTLINE: 16992600
WINDING: QT639421

CAT #: 191567.00

FR 3

TYPICAL MOTOR PERFORMANCE DATA

HP	KW	SYNC RPM	FL RPM	FRAME	ENCLOSURE	TYPE	KVA CODE	DESIGN		
1.5	1.1	1800	1745	56C	TEFC	NA	M	B		
PH	HZ	VOLTS	AMPS	START TYPE	DUTY	INSL	S.F.	AMB	ELEV.	
3	60/50	208-230/460#190/380	4.8-4.4/2.283/8/1.9	LINE OR INVERTER	CONT	F	1.15	40	3300	
F.L. EFF		3/4 LD EFF		1/2 LD EFF		ELECT. TYPE				
84.6		84.1		79.5		SQ CAGE INVERTED				
F.L. PF		3/4 LD PF		1/2 LD PF						
75.5		66.3		54.4		0.0				
F.L. TORQUE		LR AMPS @ 460 V		L.R. TORQUE		B.D. TORQUE		F.L. RISE (°C)		
4.5 LB-FT		19.9		18.1 LB-FT		402%		21.1 LB-FT		
PRESSURE @ 3		POWER		ROTOR WK²		MAX. LOAD WK²		SAFE STALL TIME	STARTS/HOUR	MOTOR WGT
999 DBA		1008 DBA		-1.00 LB-FT²		0 LB-FT²		10 SEC.	0	0 LB.

*** SUPPLEMENTAL INFORMATION ***

DE BRACKET TYPE	ODE BRACKET TYPE	MOUNT TYPE	MOTOR ORIENTATION	SEVERE DUTY	HAZARDOUS LOCATION	DRIIP COVER	SCREENS	PAINT		
C-FACE	STANDARD	ROUND	HORIZONTAL	NO	NONE	NO	NONE	NO PAINT		
BEARINGS		SHAFT TYPE		SPECIAL DE		SHAFT MATERIAL		FRAME MATERIAL		
DE ODE	GREASE	BALL BALL	STANDARD 56	NONE		303 STAINLESS (C-501)		STAINLESS STEEL		
6205										
6205										
THERMOSTATS		WIDG RTD's		BRG RTD's		THERMISTORS		SPACE HEATERS		
NONE		NOT		NONE		NONE		NA		
R1 (ohms/ph)		R2 (ohms/ph)		X1 (ohms/ph)		X2 (ohms/ph)		Xm (ohms/ph)	VIBRATION (in/sec)	FLOAT ODE
0		0		0		0		0	0.150	

INVERTER TORQUE: CONSTANT 20:1
INV. HP SPEED RANGE: 2.0 X BASE SPEED

ENCODER: NONE
BRAKE: NONE
FT-LB: NONE
VOLTAGE: NONE
NONE PPR

DATE: 1/31/2018

UL: Y
HZ:



Motor Load Data

Load	0%	25%	50%	75%	100%	115%	125%	LR
Current (Amps)	1.30	1.40	1.60	1.90	2.20	2.48	2.60	19.9
Torque (ft-lb)	0.00	1.11	2.19	3.4	4.5	5.2	5.7	18.1
RPM	1800	1785	1773	1759	1745	1.735	1730	0
Efficiency (%)		70.5	79.5	84.1	84.6	83.8	84.6	
P.F. (%)	10.2	35.7	54.4	66.3	75.5	77.9	80.1	59.5

Motor Speed Data

	LR	Pull-Up	BD	Rated	Idle
Speed (RPM)	0	257	1286	1745	1800
Current (Amps)	19.9	19.4	12.5	2.20	1.30
Torque (ft-lb)	18.1	15.3	21.1	4.5	0.00

Information Block

HP	1.5			
Sync. RPM	1800			
Frame	140			
Enclosure	TEFC			
Construction	NA			
Voltage	208-230/460#190/380 V			
Frequency	60 Hz			
Design	A			
LR Code letter	M			
Service Factor	1.15			
Temp Rise @ FL	53 °C			
Duty	CONT			
Ambient	40 °C			
Elevation	1,000 feet			
Rotor/Shaft wk ²	-1.00 Lb-Ft ²			
Ref Wdg	QT63421 FR			
Sound Pressure @ 1M	999 dBA			
VFD Rating	CONSTANT 20:1			
Outline Dwg	16992600			
Conn. Diag	005010.01			
Additional Specifications:				
0				
EQUIV CKT (OHMS / PHASE)				
R1	R2	X1	X2	Xm
0.0000	0.0000	0.0000	0.0000	0.0000

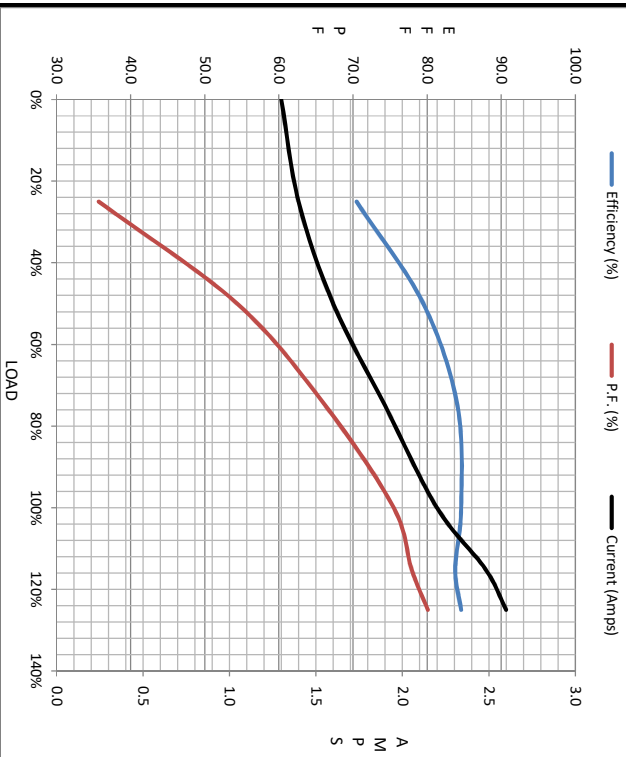

Speed - Torque Curve

