

# PRODUCT INFORMATION PACKET



Model No: A6T34XC48A

Catalog No: 119428.00

..1.5HP..3600RPM.56C.EPFC.230/460V.3PH.60HZ.CONT.40C.1.00SF.C FACE.....GENERAL  
PURPOSE.AUTO.....

Explosion Proof



Regal and Leeson are trademarks of Regal Beloit Corporation or one of its affiliated companies.

©2018 Regal Beloit Corporation, All Rights Reserved. MC017097E





### Nameplate Specifications

Output HP	1.50 Hp	Output KW	1.1 kW
Frequency	60 Hz	Voltage	208-230/460 V
Current	4.2-4.0/2.0 A	Speed	3450 rpm
Service Factor	1	Phase	3
Efficiency	84 %	Duty	Continuous
Insulation Class	B	Design Code	B
KVA Code	M	Frame	56C
Enclosure	Explosion Proof Fan cooled	Overload Protector	Automatic
Ambient Temperature	40 °C	Drive End Bearing Size	6203
Opp Drive End Bearing Size	6203	UL	Recognized
CSA	Y	CE	N
IP Code	54		

### Technical Specifications

Electrical Type	Squirrel Cage Induction Run	Starting Method	Across The Line
Poles	2	Rotation	Reversible
Mounting	Round	Motor Orientation	HORIZONTAL
Drive End Bearing	BALL	Opp Drive End Bearing	BALL
Frame Material	Rolled Steel	Shaft Type	NEMA 56
Overall Length	14.94 in	Frame Length	7.81 in
Shaft Diameter	0.625 in	Shaft Extension	1.88 in
Assembly/Box Mounting	F1 ONLY		
Outline Drawing	B-104188LE-781	Connection Diagram	EE7335-LE

NAMEPLATES TO BE READ FROM SHAFT EXT. END.

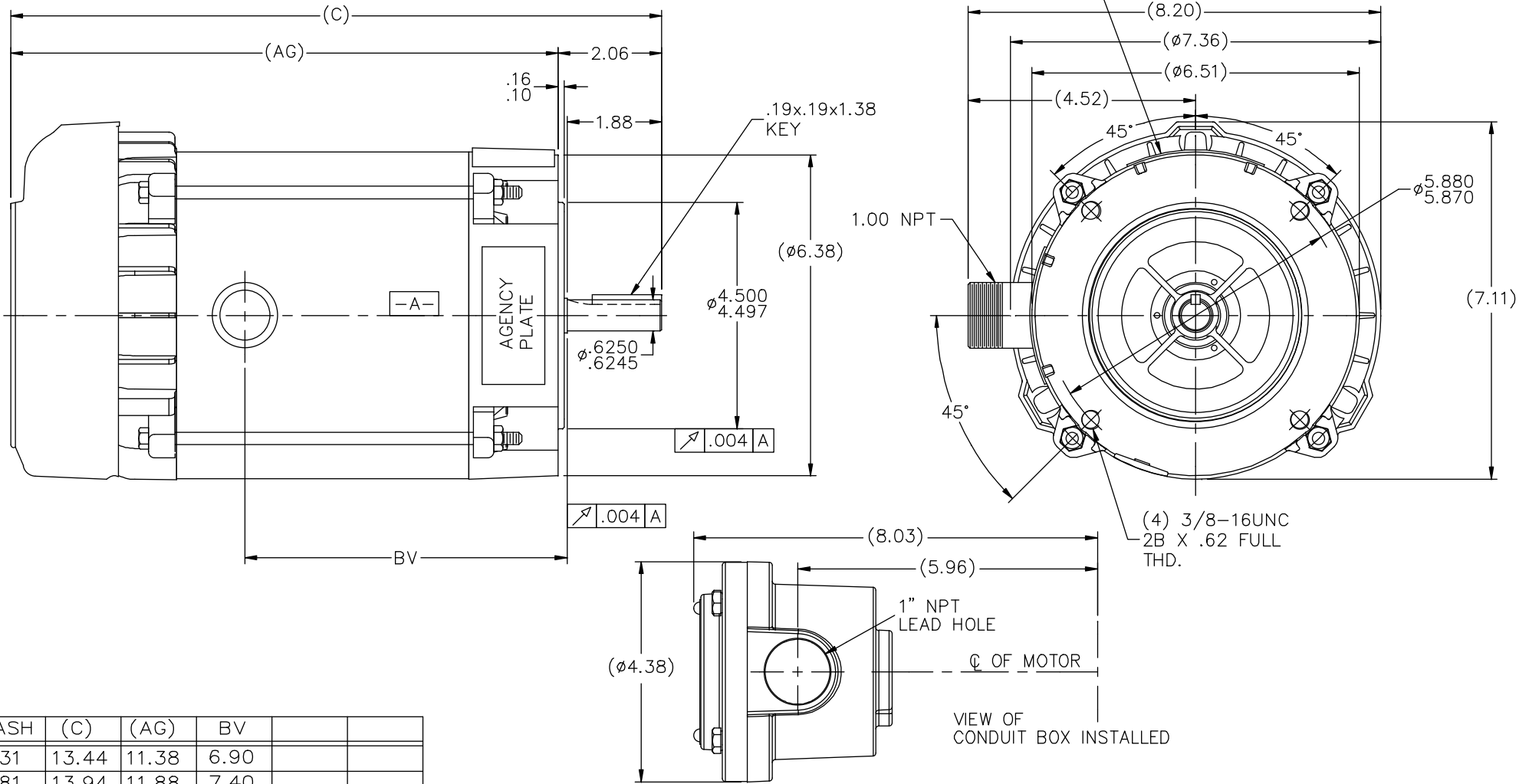

DASH	(C)	(AG)	BV		
631	13.44	11.38	6.90		
681	13.94	11.88	7.40		
731	14.44	12.38	7.90		
781	14.94	12.88	8.40		
831	15.44	13.38	8.90		
881	15.94	13.88	9.40		
931	16.44	14.38	9.90		
981	16.94	14.88	10.40		

		TOLERANCES UNLESS SPECIFIED		 ELECTRIC MOTORS GEARMOTORS AND DRIVES		DRAWN RJW 06-22-2007	
		DEC.	INCHES			CHK	ML 06-22-2007
		.X	±.1			APPD	GK 06-22-2007
		.XX	±.03				SCALE 17=32
		.XXX	±.005			REF	
01	COND. BOX INSTALLED VIEW UPDATED PER ECR-0044571	UD	10/10/13	ST	.XXXX ±.0005	MAT'L.	FMF
NO.	REVISION	BY & DATE		CHK	ANG ±7'30"	FINISH	PREV
THIS DRAWING IN DESIGN AND DETAIL IS OUR PROPERTY AND MUST NOT BE USED EXCEPT IN CONNECTION WITH OUR WORK ALL RIGHTS OF DESIGN AND INVENTION ARE RESERVED THIS IS AN ELECTRONICALLY GENERATED DOCUMENT - DO NOT SCALE THIS PRINT				RFP	06-22-2007	CAD FILE	104188LE
				DIST	WP	SIZE	DRAWING NO. PAGE OF REV. B 104188LE 01

HIGH VOLTAGE CONNECTIONS

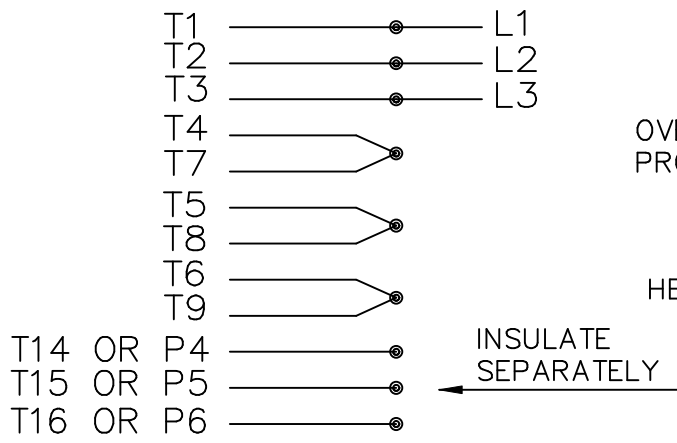

THREE PHASE - DUAL VOLTAGE MOTOR WITH OVERLOAD PROTECTOR

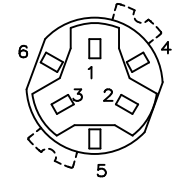

NOTE:  
ACTUAL PROTECTORS  
TERMINAL LOCATIONS  
FOR LEAD CONNECTIONS

OVERLOAD PROTECTOR  
DISC  
HEATER

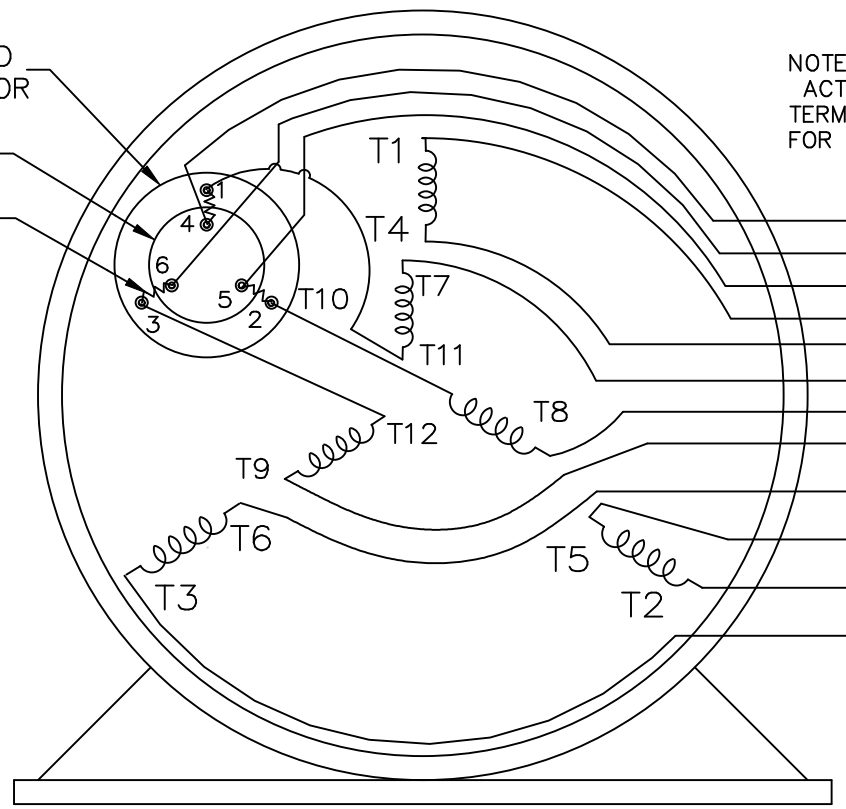

T14 OR P4  
T16 OR P6  
T15 OR P5

LOW VOLTAGE CONNECTIONS

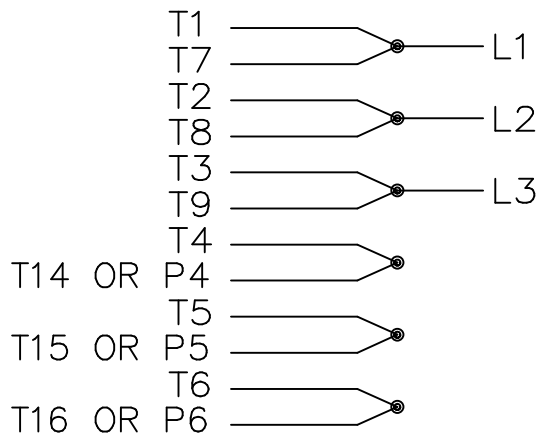

VIEW OF TERMINAL END

T2K  
T4D  
T6AN

				TOLERANCES UNLESS SPECIFIED		ELECTRIC MOTORS GEARMOTORS AND DRIVES	DRAWN NJS 04-20-2005			
				DEC.	INCHES		CHK ML 04-20-2005			
				.X	± -		APPD MJS 04-20-2005			
				.XX	± -		SCALE			
				.XXX	± -		REF			
				.XXXX	± -	MAT'L.				
NO.	REVISION	BY & DATE	CHK	ANG	± -	FINISH	PREV			
THIS DRAWING IN DESIGN AND DETAIL IS OUR PROPERTY AND MUST NOT BE USED EXCEPT IN CONNECTION WITH OUR WORK ALL RIGHTS OF DESIGN AND INVENTION ARE RESERVED THIS IS AN ELECTRONICALLY GENERATED DOCUMENT - DO NOT SCALE THIS PRINT				RFP	04-20-2005	CAD FILE EE7335_LE	SIZE A	DRAWING NO. EE7335-LE	PAGE OF	REV.
				DIST	WP					



