

PRODUCT INFORMATION PACKET



Model No: C143T17WC9A

Catalog No: 191565.00

..1HP..1800.143TC.TEFC.230/460V.3PH.60HZ.CONT.40C..C-FACE.....STAINLESS WASHDOWN.....

Paint Free



Regal and Leeson are trademarks of Regal Beloit Corporation or one of its affiliated companies.

©2018 Regal Beloit Corporation, All Rights Reserved. MC017097E





Nameplate Specifications

Output HP	1 Hp	Output KW	0.75 kW
Frequency	60 Hz	Voltage	208-230/460 V
Current	3.2-3.0/1.5 A	Speed	1750 rpm
Service Factor	1.15	Phase	3
Efficiency	85.5 %	Duty	Continuous
Insulation Class	F	Design Code	B
KVA Code	N	Frame	143TC
Enclosure	Totally Enclosed Fan Cooled	Overload Protector	No
Ambient Temperature	40 °C	Drive End Bearing Size	6205
Opp Drive End Bearing Size	6205	UL	Recognized
CSA	Y	CE	Y
IP Code	55		

Technical Specifications

Electrical Type	Squirrel Cage Inverter Rated	Starting Method	Line Or Inverter
Poles	4	Rotation	Reversible
Mounting	Round	Motor Orientation	HORIZONTAL
Drive End Bearing	BALL	Opp Drive End Bearing	BALL
Frame Material	Stainless Steel	Shaft Type	T
Overall Length	13.62 in	Frame Length	7.99 in
Shaft Diameter	0.875 in	Shaft Extension	2.25 in
Assembly/Box Mounting	F1/F2 CAPABLE		
Outline Drawing	16992700	Connection Diagram	005010.01

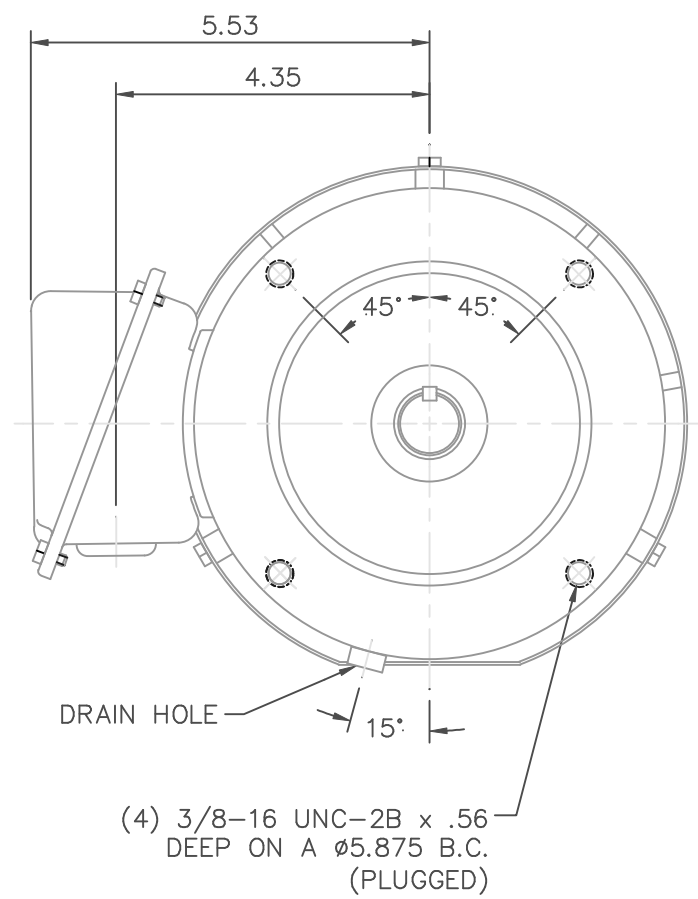
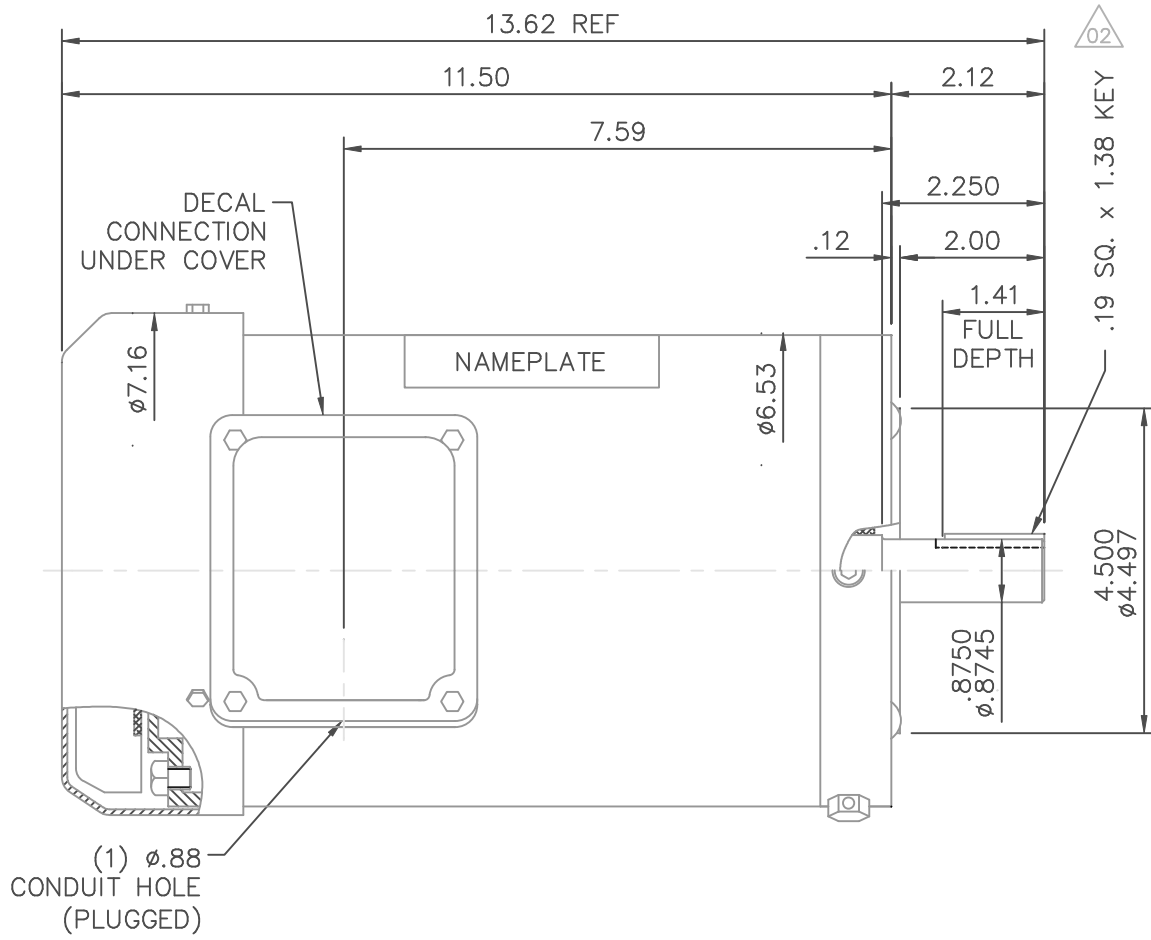

MAXIMUM FACE RUNOUT TO BE .004 T.I.R.
 MAXIMUM PILOT ECCENTRICITY .004 T.I.R.
 PERMISSIBLE SHAFT RUNOUT .002 T.I.R.

GASKETS THROUGHOUT

				TOLERANCES UNLESS SPECIFIED		 ELECTRIC MOTORS GEARMOTORS AND DRIVES	DRAWN MGM 04/09/03		
				DEC.	INCHES		CHK RDW 04/09/03	APPD	
				.X	±.1		TITLE	SCALE 3=8	
02	UPDATED SHAFT EXT DIMS	RDW 4/26/04	SW	.XXX	±.005	OUTLINE - 143-145TC FRAME	REF		
01	CONDUIT HOLE WAS 1/2-14 NPT, DIM .157 WAS .12	SW 10/7/2003	RDW	.XXXX	±.0005	TEFC - "C" FACE	FMF		
NO.	REVISION	BY & DATE	CHK	ANG	±1/2'	MAT'L.	PREV		
THIS DRAWING IN DESIGN AND DETAIL IS OUR PROPERTY AND MUST NOT BE USED EXCEPT IN CONNECTION WITH OUR WORK ALL RIGHTS OF DESIGN AND INVENTION ARE RESERVED THIS IS AN ELECTRONICALLY GENERATED DOCUMENT - DO NOT SCALE THIS PRINT				RFP	CAD FILE	16992700	SIZE	DRAWING NO.	REV.
				DIST			A	169927.00	01

005010-01

VIEW FROM OUTSIDE OF MOTOR AT SWITCH END.



VOLTAGE	L1	L2	L3	JOIN & INSULATE
HIGH	T1	T2	T3	(T4,T7) (T5,T8) (T6,T9)
LOW	T1,T7	T2,T8	T3,T9	T4,T5,T6

				TOLERANCES UNLESS SPECIFIED		Regal Beloit America, Inc.		DRAWN RDW 04/12/02				
				DEC.	INCHES			CHK				
				.X	±.1			APPD				
				.XX	±.01			SCALE 1=1				
				.XXX	±.005	TITLE		REF FIG.2-51				
A	UPDATED TO REGAL LOGO			SAJ	06/26/15	AJY	.XXXX	±.0005	MAT'L. DECAL - 004014	FMF		
NO.	REVISION			BY & DATE	CHK	ANG	±1/2"		FINISH	PREV		
THIS DRAWING IN DESIGN AND DETAIL IS OUR PROPERTY AND MUST NOT BE USED EXCEPT IN CONNECTION WITH OUR WORK ALL RIGHTS OF DESIGN AND INVENTION ARE RESERVED THIS IS AN ELECTRONICALLY GENERATED DOCUMENT - DO NOT SCALE THIS PRINT				RFP	04/12/02		CAD FILE		00501001	SIZE	DRAWING NO.	REV.
				DIST		BRF-NLV				A	005010-01	



P.O. BOX 8003
WAUSAU, WI 54401-8003
PH. 715-675-3311

DATA VOLTS: 460

CERTIFICATION DATA SHEET

CONN. DIAGRAM: 005010.01
OUTLINE: 16992700
WINDING: QTS9420

CAT #: 191565.00

FR 3

TYPICAL MOTOR PERFORMANCE DATA

HP	KW	SYNC RPM	FL RPM	FRAME	ENCLOSURE	TYPE	KVA CODE	DESIGN
1	0.75	1800	1757	143TC	TEFC	NA	N	B

PH	HZ	VOLTS	AMPS	START TYPE	DUTY	INSL	S.F.	AMB	ELEV.
3	60/50	208-230/460#190/380	3.2-3/1.583/0/1.5	LINE OR INVERTER	CONT	F	1.15	40	3300

F.L. EFF	F.L. PF	3/4 LD EFF	86.1	1/2 LD EFF	83.4	GTD EFF	0.0	ELECT. TYPE
	71.9	3/4 LD PF	62.8	1/2 LD PF	51.1			SO CAGE INVERTED

F.L. TORQUE	LR AMPS @ 460 V	13.2	LB-FT	441%	15.8	LB-FT	F.L. RISE (°C)
2.99	15.1					528%	33

PRESSURE @ 3	POWER	ROTOR WK²	MAX. LOAD WK²	SAFE STALL TIME	STARTS/HOUR	MOTOR WGT
999	1008	0.00	0	10	0	0 LB.

*** SUPPLEMENTAL INFORMATION ***

DE BRACKET TYPE	ODE BRACKET TYPE	MOUNT TYPE	MOTOR ORIENTATION	SEVERE DUTY	HAZARDOUS LOCATION	DRIIP COVER	SCREENS	PAINT
C-FACE	STANDARD	ROUND	HORIZONTAL	NO	NONE	NO	NONE	NO PAINT

BEARINGS DE	ODE	GREASE	SHAFT TYPE	SPECIAL DE	SPECIAL ODE	SHAFT MATERIAL	FRAME MATERIAL
BALL	BALL	POLYREX EM	T	NONE	NONE	303 STAINLESS (C-501)	STAINLESS STEEL

THERMOSTATS	PROTECTORS	WDG RTD's	BRG RTD's	THERMISTORS	CONTROL	SPACE HEATERS
NONE	NOT	NONE	NONE	NONE	FALSE	NA

R1 (ohms/ph)	R2 (ohms/ph)	X1 (ohms/ph)	X2 (ohms/ph)	Xm (ohms/ph)	VIBRATION (in/sec)	FLOAT ODE
0	0	0	0	0	0.150	

* NOTES	INVERTER TORQUE: CONSTANT 20:1	INV. HP SPEED RANGE: 2.0 X BASE SPEED
ENCODER: NONE		
BRAKE: NONE		
FT-LB: NONE		
VOLTAGE: NONE		
UI: Y		

DATE:	1/31/2018	HZ:
-------	-----------	-----



Motor Load Data						LR	
Load	0%	25%	50%	75%	100%	115%	125%
Current (Amps)	1.00	1.00	1.10	1.30	1.50	1.70	1.80
Torque (ft-lb)	0.00	0.74	1.48	2.23	2.99	3.5	3.8
RPM	1800	1790	1779	1768	1757	1750	1745
Efficiency (%)		74.5	83.4	86.1	86.9	84.5	86.8
P.F. (%)		31.6	51.1	62.8	71.9	74.9	75.0

Motor Speed Data

	LR	Pull-Up	BD	Rated	Idle	Information Block				
Speed (RPM)	0	193	1264	1757	1800	HP	1.0			
Current (Amps)	15.1	14.8	10.1	1.50	1.00	Sync. RPM	1800			
Torque (ft-lb)	13.2	10.5	15.8	2.99	0.00	Frame	143			
						Enclosure	TEFC			
						Construction	NA			
						Voltage	208-230/460#190/380	V		
						Frequency	60	Hz		
						Design	A			
						LR Code letter	N			
						Service Factor	1.15			
						Temp Rise @ FL	33	°C		
						Duty	CONT			
						Ambient	40	°C		
						Elevation	1,000	feet		
						Rotor/Shaft wk ²	0.00	LB-Ft ²		
						Ref Wdg	QT63420	FR		
						Sound Pressure @ 1M	999	dB(A)		
						VFD Rating	CONSTANT 20:1			
						Outline Dwg	16992700			
						Conn. Diag	005010.01			
						Additional Specifications:	0			
							EQUIV CKT (OHMS / PHASE)			
						R1	R2	X1	X2	Xm
						0.0000	0.0000	0.0000	0.0000	0.0000

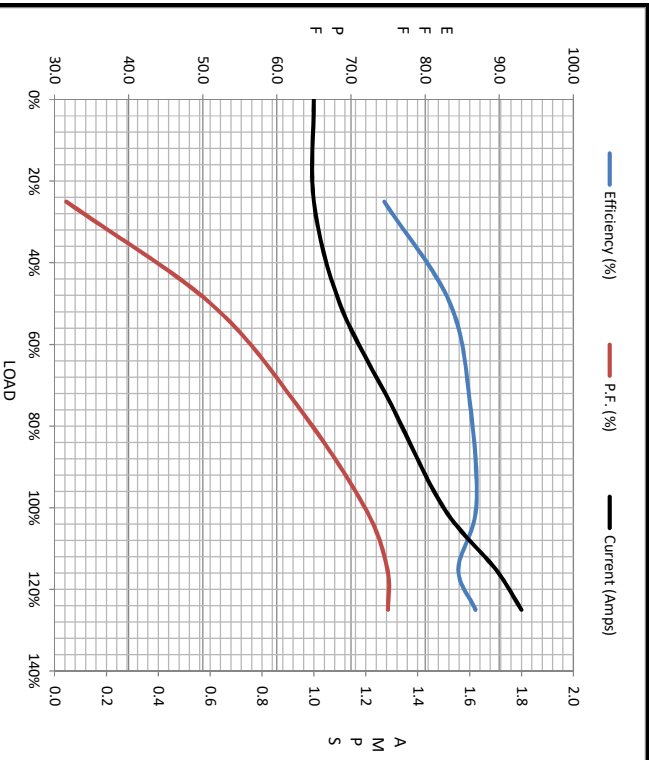

	R1	R2	X1	X2	Xm
	0.0000	0.0000	0.0000	0.0000	0.0000

