

# PRODUCT INFORMATION PACKET



Model No: 171844.60

Catalog No: 171844.60

30 HP Grain Stirring Motor, 3 phase, 1800 RPM, 208-230/460 V, 286TZ Frame, TEFC  
Grain Stirring Motors

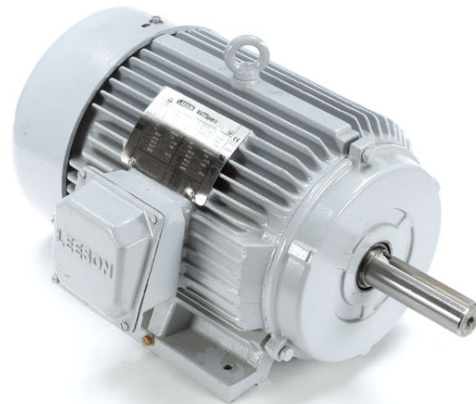

Regal and Leeson are trademarks of Regal Beloit Corporation or one of its affiliated companies.  
©2019 Regal Beloit Corporation, All Rights Reserved. MC017097E

The Regal logo is located in the bottom right corner. It features the word "REGAL" in a white, sans-serif font, set against a dark grey, trapezoidal background. The background of the entire page on the right side is a blue gradient with a halftone dot pattern.



### Nameplate Specifications

Output HP	30 Hp	Output KW	22.4 kW
Frequency	60 Hz	Voltage	208-230/460 V
Current	77.0-70.0/35.0 A	Speed	1780 rpm
Service Factor	1.15	Phase	3
Efficiency	94.1 %	Power Factor	85.6
Duty	Continuous	Insulation Class	F
Design Code	A	KVA Code	H
Frame	286TZ	Enclosure	Totally Enclosed Fan Cooled
Thermal Protection	No	Ambient Temperature	40 °C
Drive End Bearing Size	6311	Opp Drive End Bearing Size	6309
UL	Recognized	CSA	Y
CE	Y	IP Code	55

### Technical Specifications

Electrical Type	Squirrel Cage Inverter Rated	Starting Method	Wye Start Delta Run Or Inverter
Poles	4	Rotation	Reversible
Resistance Main	.052 Ohms	Mounting	Rigid base
Motor Orientation	Horizontal	Drive End Bearing	Ball
Opp Drive End Bearing	Ball	Frame Material	Cast Iron
Shaft Type	Single Special Extension	Overall Length	29.09 in
Shaft Diameter	1.875 in	Shaft Extension	5.6 in
Assembly/Box Mounting	F1/F2 CAPABLE		

This is an uncontrolled document once printed or downloaded and is subject to change without notice. Date Created:01/11/2019

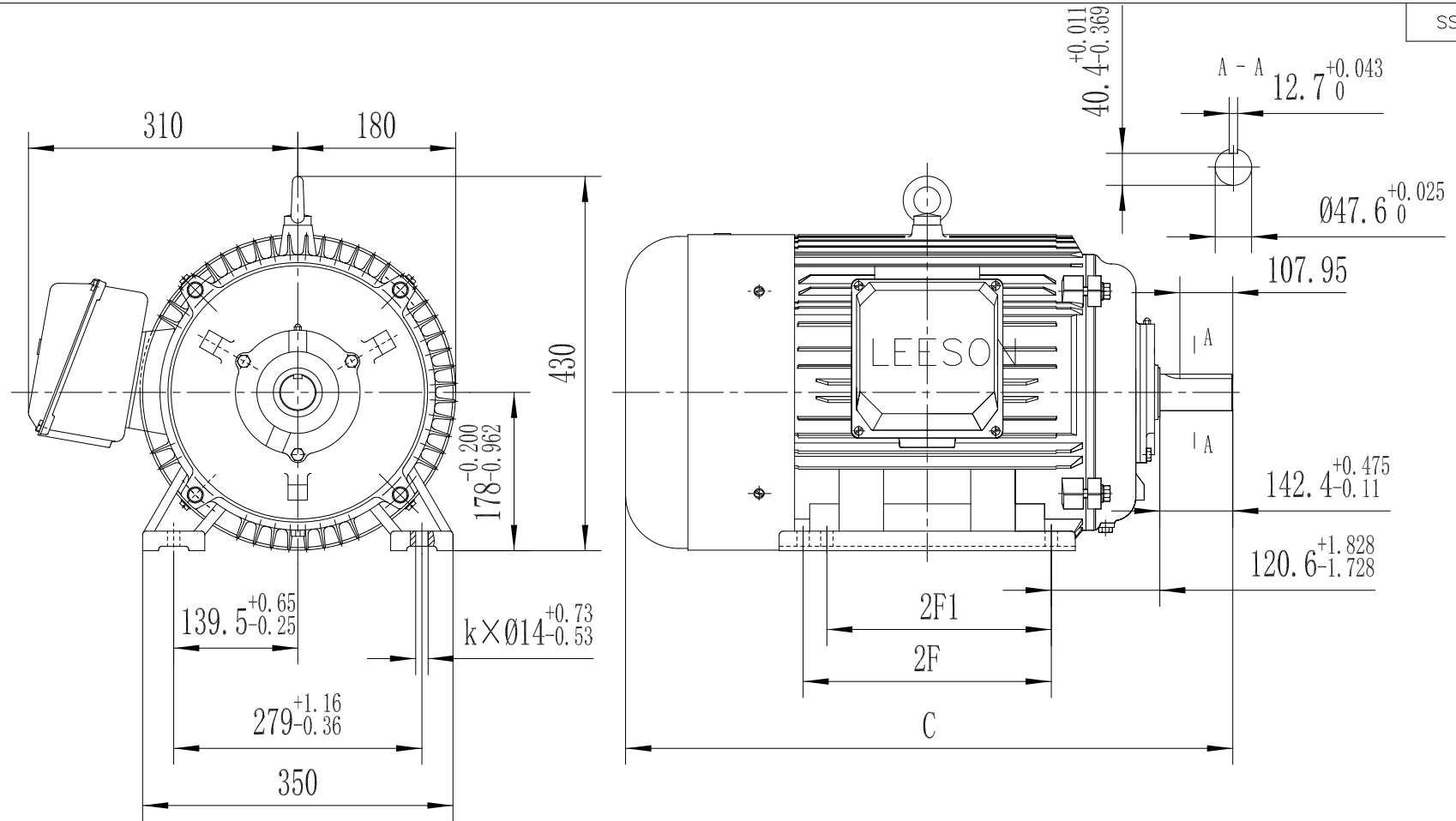

CAT. NO.	TYPE	2F	2F1	K	C
171843.60	N284TZ-4	241 <sup>+1.06</sup> <sub>-0.46</sub>		4	701
171844.60	N286TZ-4	279 <sup>+1.16</sup> <sub>-0.36</sub>	241 <sup>+1.06</sup> <sub>-0.46</sub>	6	739

		TOLERANCES UNLESS SPECIFIED		REGAL Regal-Beloit Corporation		DRAWN				
		DEC.	INCHES			CHK				
		.X	±.1	TITLE		APPD				
		.XX	±.03	OUTLINE		SCALE				
		.XXX	±.005	N280TZ-4		REF				
A	RELEASED FOR PRODUCTION ECO-0138957	WGJ	2/1/2018	EMH	.XXXX	±.0005	MAT'L.	FMF		
NO.	REVISION	BY & DATE	CHK	ANG	±1/2	FINISH	PREV			
THIS DRAWING IN DESIGN AND DETAIL IS OUR PROPERTY AND MUST NOT BE USED EXCEPT IN CONNECTION WITH OUR WORK ALL RIGHTS OF DESIGN AND INVENTION ARE RESERVED THIS IS AN ELECTRONICALLY GENERATED DOCUMENT - DO NOT SCALE THIS PRINT						RFP	CAD FILE	SIZE	DRAWING NO.	REV.
						DIST	B	SS620865	A	