

PRODUCT INFORMATION PACKET



Model No: 171845.60
Catalog No: 171845.60
3 HP Grain Stirring Motor, 3 phase, 1800 RPM, 208-230/460 V, 182TZ Frame, TEFC
Grain Stirring Motors



Regal and Leeson are trademarks of Regal Beloit Corporation or one of its affiliated companies.
©2019 Regal Beloit Corporation, All Rights Reserved. MC017097E

The Regal logo is located in the bottom right corner. It features the word "REGAL" in a white, bold, sans-serif font, set against a dark grey, trapezoidal background. The background of the entire page on the right side is a blue gradient with a halftone dot pattern.



Nameplate Specifications

Output HP	3 Hp	Output KW	2.2 kW
Frequency	60 Hz	Voltage	208-230/460 V
Current	8.3-7.8/3.9 A	Speed	1770 rpm
Service Factor	1.15	Phase	3
Efficiency	89.5 %	Power Factor	79.5
Duty	Continuous	Insulation Class	F
Design Code	B	KVA Code	J
Frame	182TZ	Enclosure	Totally Enclosed Fan Cooled
Thermal Protection	No	Ambient Temperature	40 °C
Drive End Bearing Size	6206	Opp Drive End Bearing Size	6205
UL	Recognized	CSA	Y
CE	Y	IP Code	55

Technical Specifications

Electrical Type	Squirrel Cage Inverter Rated	Starting Method	Line Or Inverter
Poles	4	Rotation	Reversible
Mounting	Rigid base	Motor Orientation	Horizontal
Drive End Bearing	Ball	Opp Drive End Bearing	Ball
Frame Material	Cast Iron	Shaft Type	Single Special Extension
Overall Length	17.10 in	Shaft Diameter	1.125 in
Shaft Extension	3.755 in	Assembly/Box Mounting	F1/F2 CAPABLE

This is an uncontrolled document once printed or downloaded and is subject to change without notice. Date Created:01/11/2019

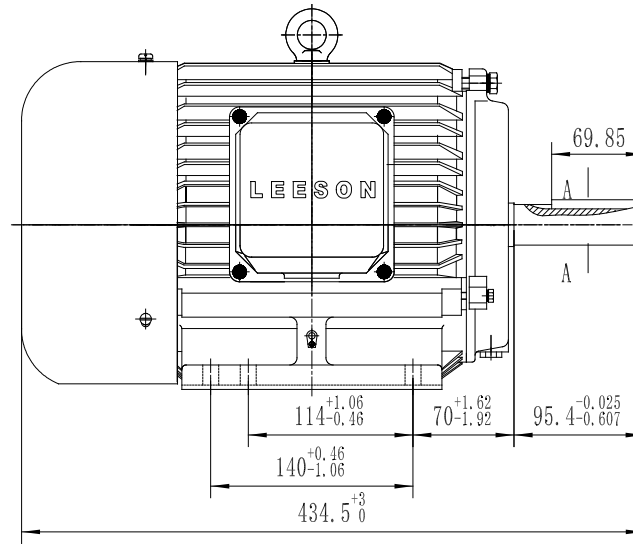
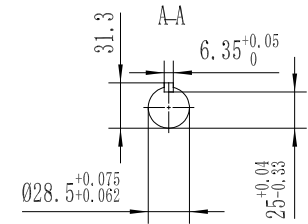
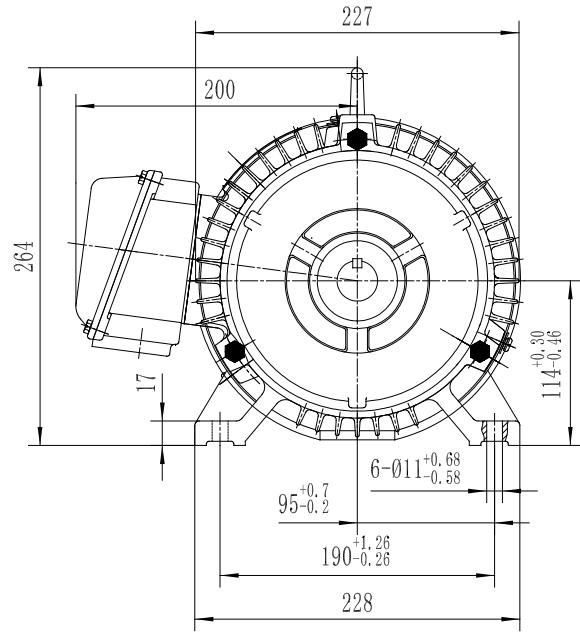

CAT NO	Type
171845.60	N182TZ-4WTC
171846.60	N184TZ-4WTC

		TOLERANCES UNLESS SPECIFIED		REGAL Regal-Beloit Corporation		DRAWN					
		DEC.	INCHES			CHK					
		.X	±.1	TITLE		APPD					
		.XX	±.03	OUTLINE		SCALE					
		.XXX	±.005	N180TZ-4		REF					
A	RELEASED FOR PRODUCTION	ECC-0138957	WGJ 2/1/2018	EMH	.XXXX	±.0005	MAT'L.	FMF			
NO.	REVISION	BY & DATE	CHK	ANG	±1/2	FINISH	PREV				
THIS DRAWING IN DESIGN AND DETAIL IS OUR PROPERTY AND MUST NOT BE USED EXCEPT IN CONNECTION WITH OUR WORK ALL RIGHTS OF DESIGN AND INVENTION ARE RESERVED THIS IS AN ELECTRONICALLY GENERATED DOCUMENT - DO NOT SCALE THIS PRINT							RFP	CAD FILE	SIZE	DRAWING NO.	REV.
							DIST	B	SS620862	A	