

**DETAIL A (5 PL.)  
(LID ATTACHMENT DETAIL)**

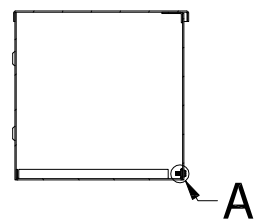

**SECTION A-A  
(INSIDE RIGHT OF ENCL.)**

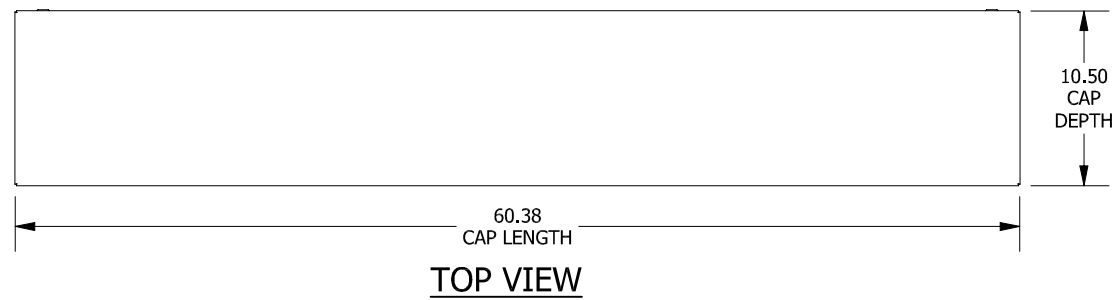
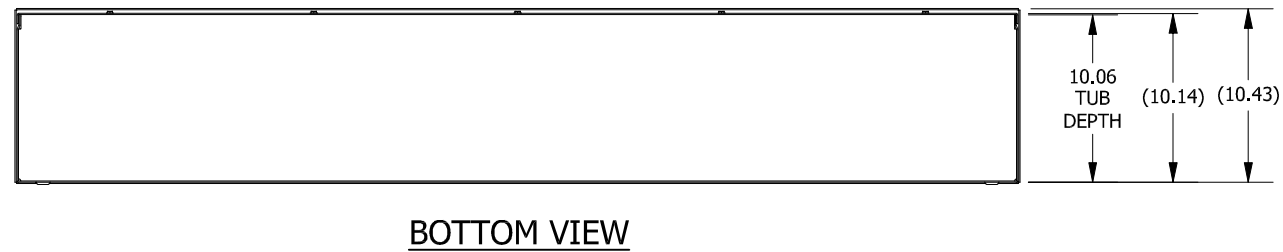
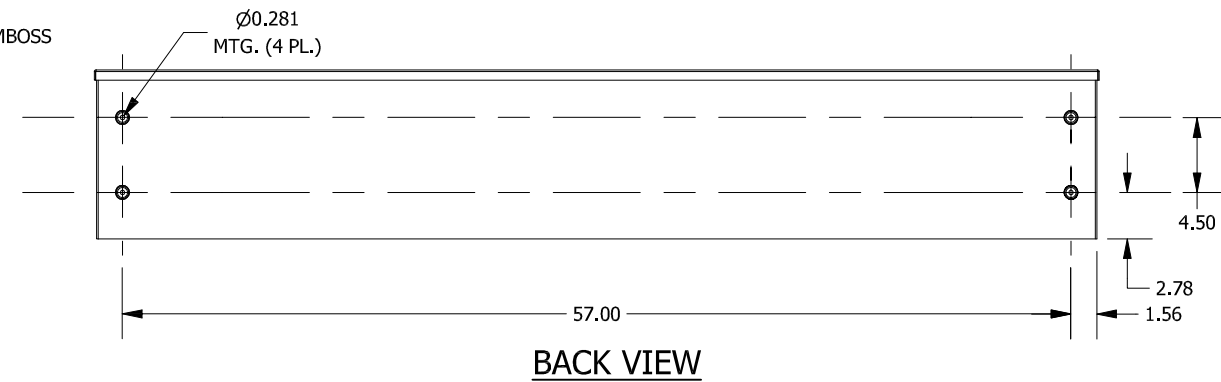
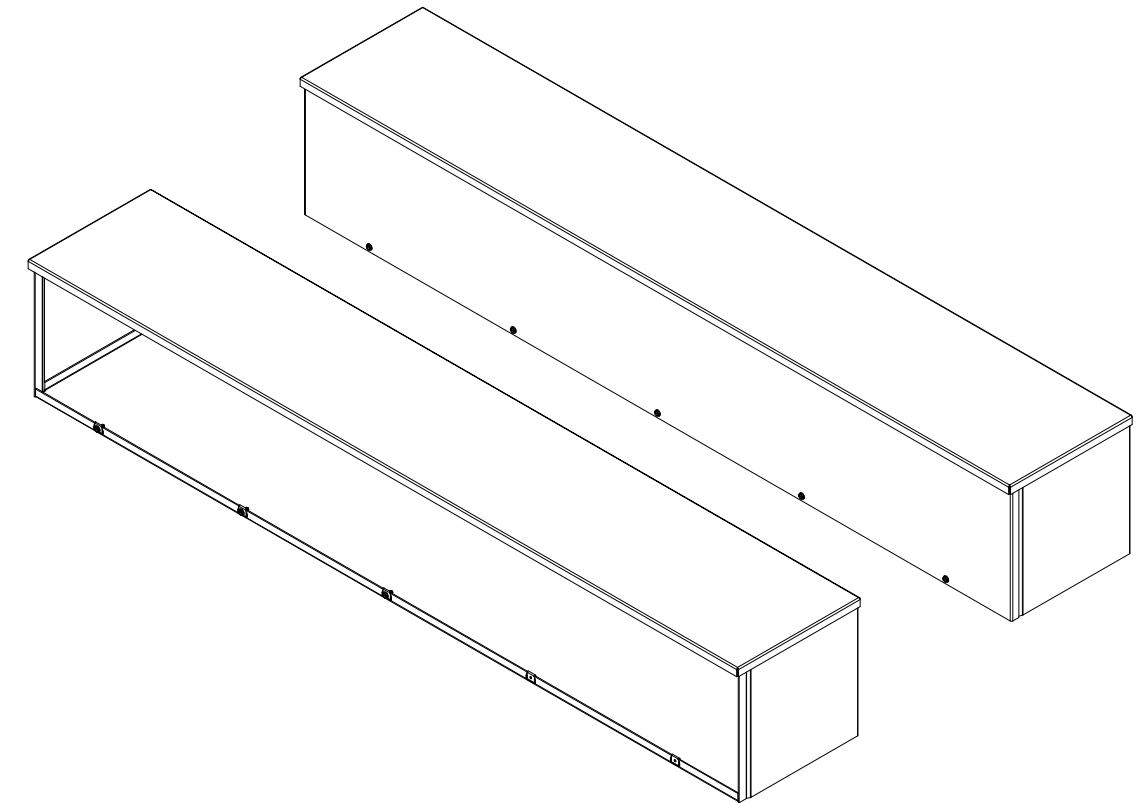
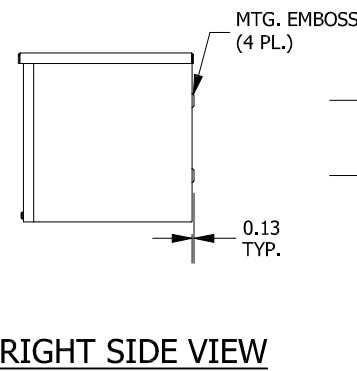
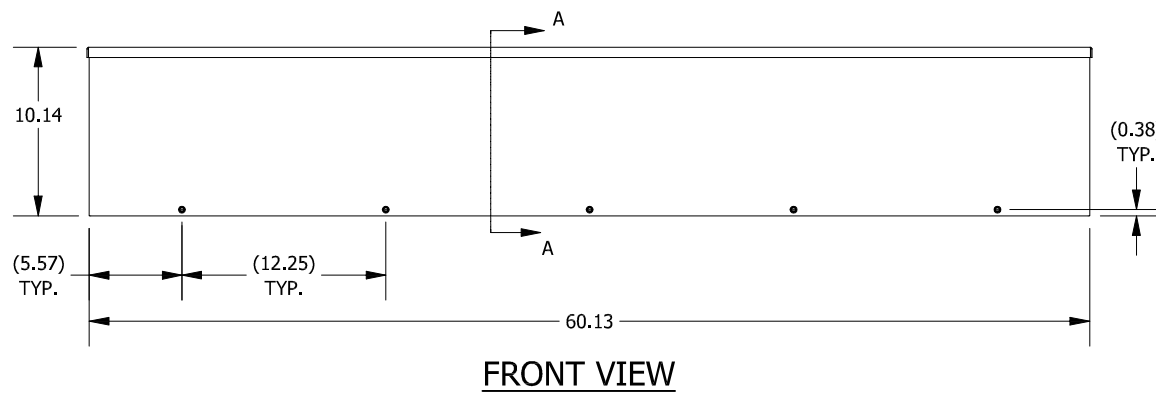

PART#: RSCG101060GNK  
(DATA SUBJECT TO CHANGE WITHOUT NOTICE)

THIS DRAWING IS PROPERTY OF HUBBELL INC. WIEGMANN  
ALL INFORMATION IS PROPRIETARY AND NOT TO BE DUPLICATED