

SPX Hydraulic Technologies  
5885 11th Street  
Rockford, IL 61109-3699 USA  
**powerteam.com**

Tech Services: (800) 477-8326  
Fax: (800) 765-8326  
Order Entry: (800) 541-1418  
Fax: (800) 288-7031

RJ100T24A  
RJ100T24A-C  
RJ100T24A-E  
RJ100T24E  
RJ100T24E-C  
RJ100T24E-E  
RJ100T37A  
RJ100T37A-C  
RJ100T37A-E  
RJ100T37E  
RJ100T37E-C  
RJ100T37E-E

## HIGH TONNAGE PORTABLE RAIL JACK

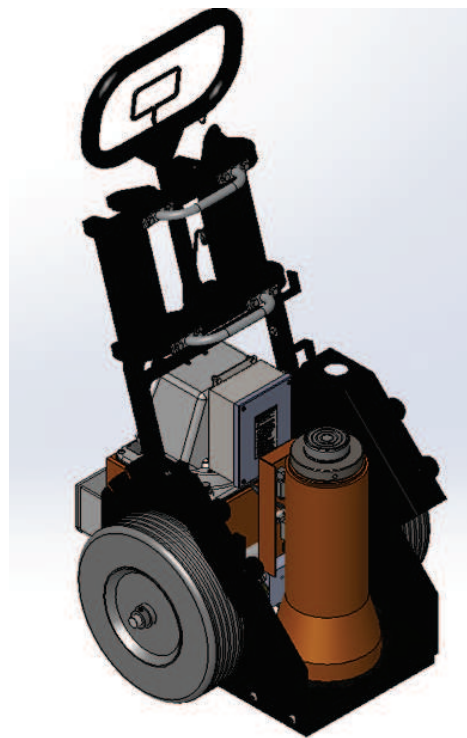

**WARNING: It is the operator's responsibility to read and understand the following safety statements,**

- These instructions should be read and carefully followed. Most problems with new equipment are caused by improper operation or installation.
- Only qualified operators should install, operate, adjust, maintain, clean, repair, or transport this machinery.

**WARNING**

**ALL WARNING STATEMENTS MUST BE CAREFULLY OBSERVED TO HELP PREVENT PERSONAL INJURY.**

## TABLE OF CONTENTS

RAIL JACKS	2
SAFETY DEFINITIONS	2
SAFETY PRECAUTIONS	2
• Hydraulic Hose	3
• Double - Acting Hydraulic Cylinder	4
• Cylinder	5
• Counterbalance valve	6
• Pump	7
• Power Supply( Electric)	7
SYSTEM EVALUATION	8
• Inspection	8
CYLINDER MAINTENANCE	8
• Periodic cleaning	8
• Storage	8
PUMP INSPECTION	9
HYDRAULIC PUMP SET-UP PROCEDURE	10
GENERAL OPERATION	12
UNIT OPERATION	13
ACCESSORIES	14
PREVENTIVE MAINTENANCE	22
• Hydraulic fluid level	22
• Lubrication (Air motor)	22
• Maintenance cleaning	22
• Draining and flushing the reservoir	23
• Adding oil to reservoir	23
• Checking brushes on universal motor	24
OPERATION	24
• Connecting valve in system	25
• Hydraulic Schematic	25
TROUBLESHOOTING GUIDE	26

# RAIL JACKS

**!WARNING:** Safety is paramount. This manual covers the general operation of the lifting jack. Each lift job has its own variable conditions and this manual cannot cover all of those conditions. It provides general guidelines for safe operation of the lifting jack. It is the responsibility of the lifting jack operator to read these instructions and understand the use and safe operation of the lifting jack, plan the lift requirements, establish the appropriate steps for each lift, determine the proper positioning for the lifting jack, and determine if any additional equipment is necessary to safely complete the lift.

## RAIL JACK MODEL DATA

Model	Rating			Retracted Height		Stroke		Weight		power
	short tons	metric tons	kN	in	mm	in	mm	lb	kg	
RJ100T24A	100	90	889	24	610	14	355	658	299	AIR
RJ100T24E	100	90	889	24	610	14	355	676	307	ELECTRIC
RJ100T37A	100	90	889	37	940	26	660	768	348	AIR
RJ100T37E	100	90	889	37	940	26	660	786	357	ELECTRIC

## SAFETY DEFINITIONS

Safety symbols are used to identify any action or lack of action that can cause personal injury. Your reading and understanding of these safety symbols is very important.



Danger is used only when your action or lack of action will cause serious human injury or death.

 **WARNING**

Warning is used to describe any action or lack of action where a serious injury can occur.

 **DANGEROUS VOLTAGE**

Dangerous Voltage is used to describe any action or lack of action that could cause serious personal injury or death from high voltage electricity.

 **CAUTION**

Caution is used when action or lack of action can cause equipment failure, either immediate or over a long period of time.

## SAFETY PRECAUTIONS

 **WARNING**

To help prevent personal injury,

### HYDRAULIC HOSE

- Before operating the pump, all hose connections must be tightened with the proper tools. Do not overtighten. Connections should only be tightened securely and leak-free. Overtightening can cause premature thread failure or high pressure fittings to split at pressures lower than their rated capacities.
- Always shut off the electric motor before breaking any connections in the system.
- Should a hydraulic hose ever rupture, burst, or need to be disconnected, immediately shut off the pump. Never attempt to grasp a leaking pressurized hose with your hands. The force of escaping hydraulic fluid could cause serious injury.
- Do not subject the hose to potential hazard such as fire, sharp surfaces, extreme heat or cold, or heavy impact. Do not let the hose kink, twist, curl or bend so tightly that oil flow within the hose is blocked or reduced. Periodically inspect the hose for wear, because any of these conditions can damage the hose.
- Do not use the hose to move attached equipment. Stress can damage the hose, causing personal injury.





- Hose material and coupler seals must be compatible with the hydraulic fluid used. Hoses also must not come in contact with corrosive materials such as creosote-impregnated objects and some paints. Consult the manufacturer before painting a hose. Never paint the couplers. Hose deterioration due to corrosive materials can result in personal injury.

### PUMP

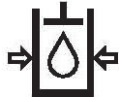

- Do not exceed the PSI hydraulic pressure rating noted on the pump nameplate or tamper with the internal high pressure relief valve. Creating pressure beyond rated capacities can result in personal injury.
- Before replenishing the oil level, retract the system to prevent overfilling the pump reservoir. An overfill can cause personal injury due to excess reservoir pressure created when the cylinders are retracted.

### CYLINDER

- Do not exceed the rated capacities of the cylinders. Excess pressure can result in personal injury.
- Do not set poorly balanced or off-center loads on a cylinder. The load can tip and cause personal injury.

## DOUBLE-ACTING HYDRAULIC SYSTEMS

A basic double-acting hydraulic system consists of a pump (which moves the hydraulic fluid), a double-acting cylinder (to do the work), a hydraulic hose (which routes the fluid to the advance cylinder port), a second hydraulic hose (which routes the fluid to the retract cylinder port), and a control valve which can change the direction of the hydraulic fluid.

### TYPICAL INSTALLATION

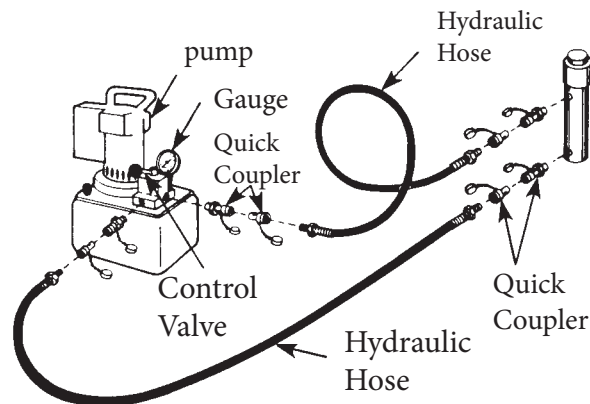

A double-acting cylinder can be either extended or retracted hydraulically.

Most double-acting cylinders are classed as “differential cylinders” because of the different sized areas that the hydraulic fluid pushes against during the extend and retract strokes. Because of this difference, the extend stroke can exert more force than the retract stroke.

**NOTE: The capacity of a hydraulic system is determined by the effective area of the cylinder and the system pressure.**

## **⚠ DANGER** Cylinder

- A double-acting cylinder must have both hoses and all couplers securely connected to both ports. If one of the two ports is restricted or becomes disconnected, pressure will build and the cylinder, hose or coupler can burst, possibly causing serious injury or death.
- When extending double-acting cylinders, the retract port must not be restricted. A restricted retract port will prevent pressure from being released and the cylinder can burst, possibly causing serious injury or death.
- DO NOT attempt to adjust or service the rod end relief valve on a double-acting cylinder. If oil leakage is detected from this relief valve, discontinue use of the cylinder immediately and contact your nearest Authorized Hydraulic Service Center. If improperly adjusted, the cylinder could develop excessive pressure and cause the cylinder, hose or couplers to burst which could cause serious injury or death.
- The user must be a qualified operator familiar with the correct operation, maintenance, and use of the cylinder(s). Lack of knowledge in any of these areas can lead to personal injury.
- Read and understand all safety and warning decals and instructions.
- Use only approved accessories and approved hydraulic fluid. Hoses, seals and all components used in a system must be compatible with the hydraulic fluid used.
- Do not exceed the rated capacities of the cylinders. Excess pressure can result in personal injury.
- Inspect each cylinder, fitting, tube line, hose, valve and coupler before each shift or usage to prevent unsafe conditions from developing.
- Do not use cylinders if they are damaged, altered or in poor condition.
- Do not use cylinders with bent or damaged couplers or damaged port threads.
- Under certain conditions, the use of an extension with a hydraulic cylinder may not be advisable and could present a dangerous condition.
- Avoid pinch points or crush points that can be created by the load or parts of the cylinder.
- To help prevent material fatigue if the cylinder is to be used in a continuous application, the load should not exceed 80% of the rated capacity.
- Cylinder must be on a stable base which is able to support the load while pushing or lifting.
- To help prevent personal injury, use shims, friction material or constraints to prevent slippage of the base or load.
- Surfaces contacting the cap must be parallel to the base supporting surface within 2.5°.
- 100% of the load cap and base must be supported securely when pushing or lifting a load.
- Block or secure the load to prevent movement during lifting.
- Do not set poorly-balanced or off-center loads on a cylinder. The load can tip or the cylinder can “kick out” and cause personal injury.
- Do not exceed 2.5° misalignment of the load on the cap (Shown in figure 1).
- If this component is used to lift or lower loads, be certain that the load is under operator control at all times and that others are clear of the load. Do not drop the load.
- As the load is lifted, use appropriate mechanical supports to guard against a falling load.
- To help prevent personal injury, do not allow personnel to go under or work on a load before it is supported mechanically. All personnel must be clear of the load before lowering.
- Never use extreme heat to disassemble a hydraulic cylinder. Metal fatigue and/or seal damage will result and can lead to unsafe operating conditions.

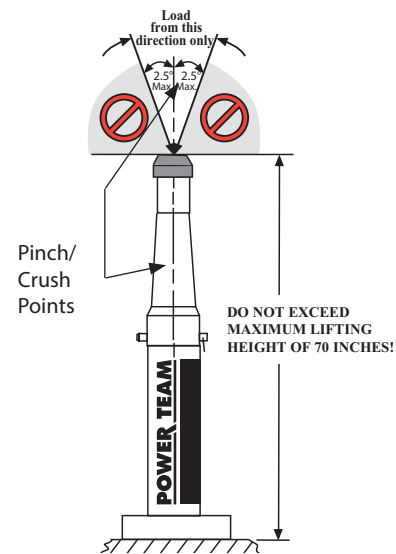

Figure 1

**Cylinder (cont.)**

- When extending a cylinder under load, always insure that the coupler(s) or port thread(s) has (have) not been damaged or do(es) not come in contact with any rigid obstruction. If this condition does occur, the coupler's attaching threads may become stripped or pulled from the cylinder resulting in the instantaneous release of high pressure hydraulic fluid, flying objects, and loss of the load. All of these possible results could cause serious injury or death.
- Avoid off-center loads which could damage the cylinder and/or cause loss of the load, possibly causing serious injury or death.
- Control the load at all times. Do not drop the load.
- Properly rated adapters must be installed and used correctly for each application.

**IMPORTANT:**

- Keep the cylinder clean at all times.
- While at a job site, when the cylinder is not in use, keep the piston rod fully retracted.
- Use an approved, high-grade pipe thread sealant to seal all hydraulic connections. PTFE tape can be used if only one layer of tape is used and it is applied carefully (two threads back) to prevent the tape from being pinched by the coupler and broken off inside the pipe end. Any loose pieces of tape could travel through the system and obstruct the flow of fluid or cause jamming of precision-fit parts.
- Always use protective covers on disconnected quick couplers.
- When mounting cylinders using the internal piston rod threads, collar threads, threaded tie rods or base mounting holes, the threads must be fully engaged. Always use SAE grade 8 or better fasteners when attaching components to cylinders and tighten securely.

**COUNTERBALANCE VALVE**

**Note: This counterbalance valve is NOT serviceable, and must be returned to your authorized Power Team service center for any service.**

Read and carefully follow these instructions before installation and use of this valve. Most problems with new equipment are caused by improper operation and installation.

**WARNING**

- All WARNING statements must be carefully observed to help prevent personal injury.
- As with all hydraulic valves, this valve is designed to lift, lower, and control the load. However, appropriate mechanical supports MUST BE used to support the load and provide adequate protection and safety.
- The operational nature of a counterbalance valve is to use the rod end pilot pressure to sense and control the load. Because of this, a portion of this pressure is added to the load pressure at the base end of the cylinder.

## PUMP

- Do not exceed the PSI hydraulic pressure rating noted on the pump nameplate or tamper with the internal high pressure relief valve. Creating pressure beyond rated capacities may result in personal injury.
- Before replenishing the oil level, retract the system to prevent overfilling the pump reservoir. An overfill may cause personal injury due to excess reservoir pressure created when cylinders are retracted.



### POWER SUPPLY (Electric)

- Never use an ungrounded power supply with this unit.
- The pump must be compatible with existing line voltage.
- Disconnect the pump from the power supply when performing maintenance or repair on the unit.
- If the unit's power supply is damaged or the inner wiring is exposed in any way, replace immediately.
- Any electrical work must be done by a qualified electrician.
- If the power cord is damaged or wiring is exposed, replace or repair immediately.
- All voltages must be wired for CW rotation when viewed from the lead end (top) of the motor.
- Check the total amperage draw for the electrical circuit you will be using. (For example: Do not plug a motor or motors that may draw 25 amps into a 20 amp fused electrical circuit.)
- Do not attempt to increase the powerline capacity by replacing a fuse with another fuse of higher value. Overheating of the powerline and the possibility of a fire will result.
- Circuit Breakers: If motor stops due to an overload or power outage, Universal Motor: Move motor switch to OFF and control valve to neutral. Let motor cool or wait until power is restored. Reset circuit breaker switch in power panel. (The pump motor doesn't have a circuit breaker.)



# SYSTEM EVALUATION

Your cylinder, hose(s), couplings and pump all must be rated for the same maximum operating pressure, correctly connected and compatible with the hydraulic fluid used. An improperly matched system can cause the system to fail and possibly cause serious injury. If you are in doubt, consult your nearest Power Team facility.

## INSPECTION

Before each use, visually inspect for the following items:

1. Cracked or damaged cylinder
2. Excessive wear, bending, damage, or insufficient thread engagement
3. Leaking hydraulic fluid
4. Scored or damaged piston rod
5. Improperly functioning or damaged heads and caps
6. Loose bolts or cap screws
7. Damaged or improperly assembled accessory equipment
8. Modified, welded, or altered equipment
9. Bent or damaged couplers or port threads

Preventive Maintenance (yearly or sooner, if the cylinder condition suggests damage) - Visual examination by the operator or other designated personnel with a dated and signed equipment record.

## CYLINDER MAINTENANCE

- Always use clean, approved hydraulic fluid and change as needed.
- Any exposed threads (male or female) must be cleaned and lubricated regularly, and protected from damage.
- If a cylinder has been exposed to rain, snow, sand, grit-laden air, or any corrosive environment it must be cleaned, lubricated, and protected immediately after exposure.

## PERIODIC CLEANING

A routine should be established to keep the hydraulic system as free from dirt as possible. All unused couplers must be sealed with dust covers. All hose connections must be free of dirt and grime. Any equipment attached to the cylinder must be kept clean.



**WARNING: Contamination of the hydraulic fluid could cause the valve to malfunction. Loss of the load or personal injury could result.**

Use only Power Team hydraulic fluid and change as recommended or sooner if the fluid becomes contaminated (never exceed 300 hours).

## STORAGE

### Double-acting Cylinders

These units should be stored in a dry, well-protected area where they will not be exposed to corrosive vapors, dust or other harmful elements.

If a unit has been stored for a year or more, it must be thoroughly inspected before it is used.

# AIR OR ELECTRIC TWO-STAGE HYDRAULIC PUMP

5,000 OR 10,000 PSI

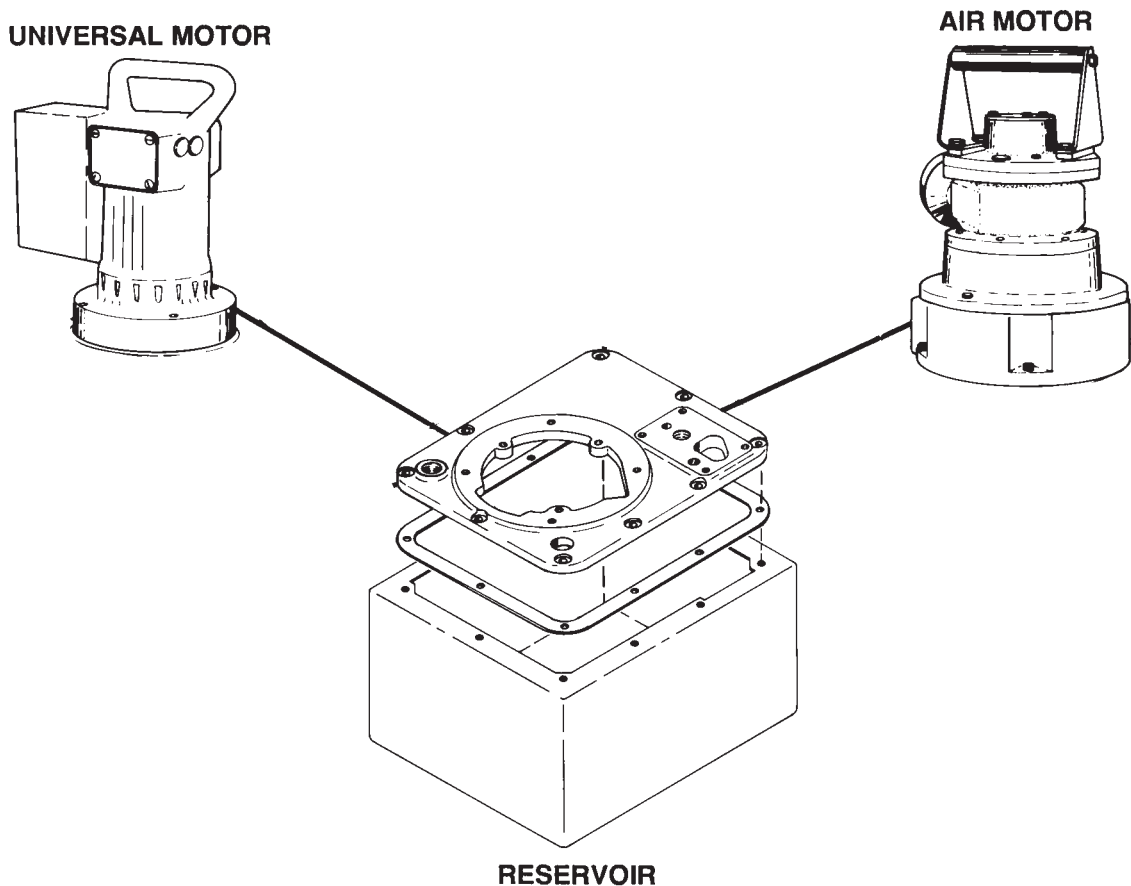

Figure 2

## NOTES:

- Carefully inspect the pump upon arrival. The carrier, not the manufacturer, is responsible for any damage resulting from shipment.
- Read and carefully follow these instructions. Most problems with new equipment are caused by improper operation or installation.
- Do not change motors without consulting the pump manufacturer's Technical Services Department.

# HYDRAULIC PUMP SET-UP PROCEDURE

## 1. Motor Hook-up and Operation

### A. Universal Motor

The universal motor is wired for 115 or 230 volts, 50/60 cycles according to the customer's request. This motor cannot be rewired.

### B. Air Motor

Remove the thread protectors from the air inlet, and install the air supply fittings (not supplied) as shown in Figure 3. Air supply must be minimum 50 CFM and 80 PSI, with 100 PSI maximum.

**Note: Seal all external pipe connections with a high-quality, nonhardening thread sealant. PTFE tape can be used to seal hydraulic connections if only one layer of tape is used. Apply the tape carefully, two threads back, to prevent it from being pinched by the coupler and broken off inside the system. Any loose pieces of tape could travel through the system and obstruct the flow of oil or cause jamming of precision-fit parts.**

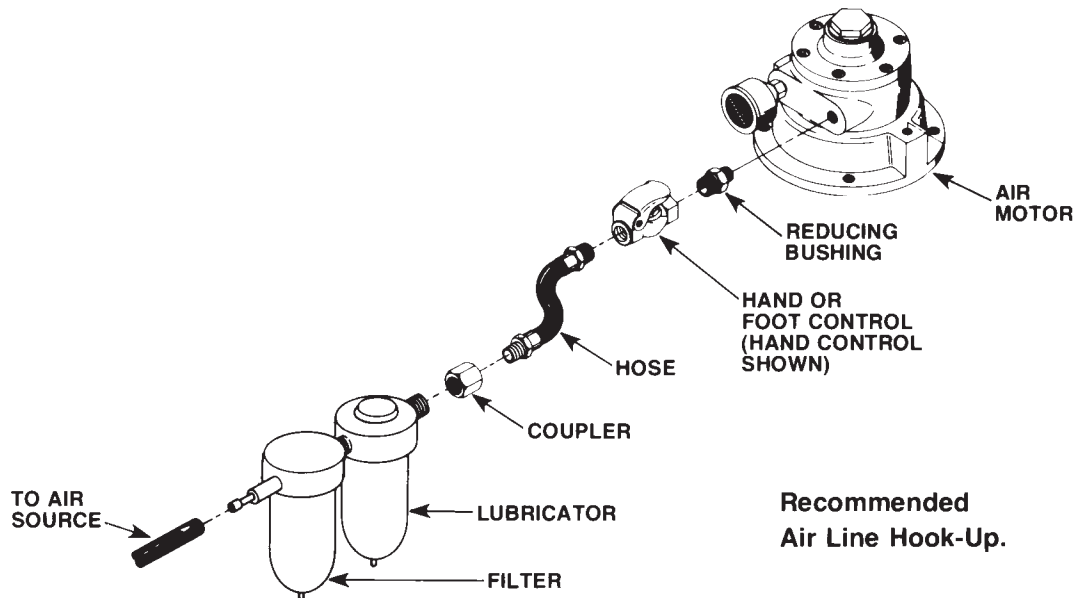

Figure 3

# HYDRAULIC PUMP SET-UP PROCEDURE (CONT.)

## 1. Filling The Reservoir

**Note: The pump has been shipped without oil in the reservoir. High-grade hydraulic oil has been shipped with the pump in a separate container. If additional oil is required, use a high-grade, approved hydraulic oil.**

- A. Clean the area around the filler cap to remove all dust and grit. Any dirt or dust in the oil can damage the polished surfaces and precision-fit components of the pump.
- B. Retract all cylinders to the return position.
- C. Remove the filler cap, and insert a clean funnel and filter. Fill with hydraulic oil to 1/2" from the top of the filler hole. Replace filler cap with the breather-hole in the filler cap open.
- D. Cycle the pump (with cylinders attached) several times. Retract the cylinders, and check the oil level in the pump reservoir again.

## 2. Priming The Pump

When operating the pump for the first time:

- A. Valve and hose connections must be tight, and the reservoir must be filled to the proper oil level. Start the motor.
- B. Jog the pump several times to build pressure. If the pump doesn't build pressure, it may not be primed. Disconnect a hose from the system and route it back to the pump reservoir. Run the pump until a steady flow of oil is observed free of suspended air bubbles. Reconnect the hose to the system.
- C. Run cylinder out to its full travel several times to eliminate air from the system. For more complete instructions, refer to the section titled "Bleeding Air From The System" on page 11.
- D. The pump is ready to be put into regular operation.

## 3. Hydraulic Connections

- A. Clean all the areas around the oil ports of the pump and cylinder.
- B. Inspect all threads and fittings for signs of wear or damage, and replace as needed.
- C. Clean all hose ends, couplers or union ends.
- D. Remove the thread protectors from the hydraulic oil outlets. Connect the hose assembly to the hydraulic oil outlet, and couple the hose to the cylinder. Although a high-grade, non-hardening thread sealant is preferred, PTFE tape may be used to seal hydraulic connections if only one layer of tape is used. Apply carefully to prevent the tape from being pinched by the coupler and broken off inside the pipe end. Any loose pieces of tape could travel through the system and obstruct the flow of oil.

## SET-UP AND OPERATION (CONT.)

### 4. BLEEDING AIR FROM THE SYSTEM

The portable jack has been bled at the factory, however, air can accumulate in the hydraulic system if the reservoir oil level is too low or if the unit has not been used for a prolonged period. This air can cause the jack to respond in an unstable or slow manner. Before attempting to lift a load for the first time remove the air:

A. Check the pump reservoir level. Refer to the pump operating instructions (page no) for the proper fill level and direction on how to add oil if necessary.

B. With no load on the jack, cycle the hydraulic system three or more times (fully extend and retract the jack).

### PORTABLE RAIL JACK GENERAL OPERATION

- This portable jack is intended for lifting applications only. It is not intended to support the load after the lift. Optional cribbing block sets are available to mechanically sustain the load after the lift. No load should ever be held hydraulically. Always use appropriate mechanical supports to hold a load.
- Do not beat or hammer on or near any part of this unit! Sharp or sudden impacts can cause undue stress on highly loaded parts which can result in equipment damage or possible personal injury.
- Stand to the side of the unit and back as far as the remote control cord will allow during lifting or lowering operation.
- A qualified individual should carefully inspect the unit before each use. This individual should look for any abnormal condition that may present a potentially hazardous situation. If any abnormal condition is found, do not use the equipment until it is corrected and approved for use.
- It is the user's responsibility to wear protective equipment as dictated by federal, state or local laws. As a minimum, it is suggested that the operator and anyone else in the work area, wear safety glasses, safety shoes, and a hard hat.



# INSTRUCTIONS REQUIRED TO PUT PORTABLE JACK INTO SERVICE

**NOTE:** Before operating this portable jack, carefully follow all the steps given below.

- STEP 1. Carefully read and understand the Safety Precautions and Operating Instructions. These safety precautions and operating instructions describe general safety precautions and the method required to connect the pump, hoses, fittings, and jack. Since this unit has been completely assembled and tested at our factory, follow the succeeding steps to put the jack into service.
- STEP 2. Carefully remove all packing materials from the assembled unit.
- STEP 3. Fill pump reservoir to proper operating level using approved Power Team hydraulic oil.
- STEP 4. Start pump and cycle jack to full extension, then to full retraction, three or more times until the jack advances and retracts smoothly throughout the cycle.
- STEP 5. Allow the pump to build to full pressure with the jack first fully extended, and then fully retracted. Stop pump and check each hose, fitting, and other system components for any oil leakage. If any leakage is found, correct the problem and retest.

## UNIT OPERATION



**DANGER: Only qualified individuals should operate this equipment.**

When using a rail jack to lift a load, it is important to:

1. Position the unit under the load to be lifted and select the extension or space Required.
2. Place a thin piece of compression material with good friction characteristics (e.g., ¼ to 3/8 inch thick plywood) between the load cap and the load lift point.
3. Confirm that the load is centered and evenly distributed on the load cap of the jack.
4. Confirm that the jack base is 100% supported on a foundation that will fully support the total load.
5. Confirm that the load is restrained from moving in any direction other than the lift direction.



**DANGER: Do not exceed the maximum lifting height of 70”**

1. Connect the unit to the proper power supply (refer to the power pump operating instructions).
  2. Shift directional valve to neutral position (See Figure 4), activate the remote switch to confirm pump is operational. Release remote switch.
  3. Shift directional valve towards port A (see figure 5).
- Advance the jack by activating the unit's remote switch until the jack comes in contact with the load. Continue to advance the jack, lifting the load in increments of one cribbing block. Install a cribbing block with each increment raised as needed. Lift the load to the desired height. At this time appropriate mechanical supports should be installed to hold the load.

**! DANGER: The cylinder must not exceed  $\pm 2.5^\circ$  from centerline alignment at any time, with or without extensions.**

5. To lower the load:  
Start the unit and raise the load just enough to remove the mechanical supports and cribbing blocks. Switch the valve to retract ( See Figure 6) and lower the load. NOTE: This unit is equipped with a load lowering valve that requires pump pressure throughout the lowering operation.

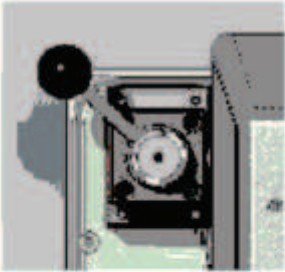

**(Neutral)  
Figure 4**

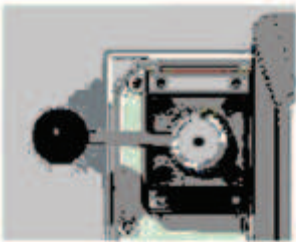

**(Extend)  
Figure 5**

#### **DIRECTION VALVE POSITIONS**

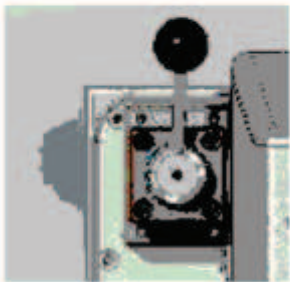

**(Retract)  
Figure 6**

## **RAIL JACK ACCESSORIES**

Accessories are available to provide flexibility in using your lift equipment. These accessories include spacers, extensions, crib blocks and swivel caps.

## **SPACERS, EXTENSIONS, CRIB BLOCKS and SWIVEL CAPS**

Accessory	Description
RJ-SP-1	1 inch spacer
RJ-SP-2	2 inch spacer
RJ-SP-3	3 inch spacer
RJ-EXT5	5 inch extension
RJ-EXT7	7 inch extension
RJ-EXT9	9 inch extension
RJ-EXT11	11 inch extension
RJ-EXT14	14 inch extension
RJ-EXT18	18 inch extension
RJ-CB1	1 inch crib block
RJ-CB3	3 inch crib block
RJ-CB5	5 inch crib block
RJ-CB10	10 inch crib block

Table: 1

While the stroke length of the jacking cylinder is dependent upon jack model, the use of spacers and extensions will increase the maximum lift “height” each jack will achieve. When increasing the lift height by using spacers and/or extensions, it is extremely important to remember:

1. Place a thin piece of compression material with good friction characteristics (e.g., ¼ to 3/8 inch thick plywood) between the load cap and the load lift point.
2. Confirm that the load is centered and evenly distributed on the load cap of the jack.
3. Confirm that the jack base is 100% supported on a foundation that will fully support the total load.
4. Confirm that the load is restrained from moving in any direction other than the lift direction.

**! DANGER Failure to comply may cause excessive side loading / tangential loading at the load cap. Sideloads can cause the lift equipment (jack, extensions, spacers, load caps) to become dislodged from under the load – causing the load to drop as jack components rapidly fly out from under the load. Failure to comply may result in extreme property damage, serious injury or death.**



Table: 2

RJ100T24x Series Rail Jack										
	1	2	3	5	7	9	11	14	18	MAX HEIGHT
STROKE	RJ-SP-1	RJ-SP-2	RJ-SP-3	RJ-EXT5	RJ-EXT7	RJ-EXT9	RJ-EXT11	RJ-EXT14	RJ-EXT18	INCHES
RETRACTED										24
1										25
2										26
3										27
4										28
5										29
6										30
7										31
8										32
9										33
10										34
11										35
11	X									36
11		X								37
11			X							38
10				X						39
11				X						40
11	X			X						41
11		X		X						42
11			X	X						43
11					X					42
11	X				X					43
11		X			X					44
11			X		X					45
11						X				44
11	X					X				45
11		X				X				46
11			X			X				47
11							X			46
11	X						X			47
11		X					X			48
11			X				X			49
11								X		49
11	X							X		50
11		X						X		51
11			X					X		52
11									X	53

Table: 2

RJ100T37x Series Rail Jack							
	1	2	3	5	7	9	MAX HEIGHT
STROKE	RJ-SP-1	RJ-SP-2	RJ-SP-3	RJ-EXT5	RJ-EXT7	RJ-EXT9	INCHES
RETRACTED							37
1							38
2							39
3							40
4							41
5							42
6							43
7							44
8							45
9							46
10							47
11							48
12							49
13							50
14							51
15							52
16							53
17							54
18							55
19							56
20							57
21							58
21	X						59
21		X					60
21			X				61
20				X			62
21				X			63
21	X			X			64
21		X		X			65
21			X	X			66
21					X		65
21	X				X		66
21		X			X		67
21			X		X		68
21						X	67
21	X					X	68
21		X				X	69
21			X			X	70

## SPACERS

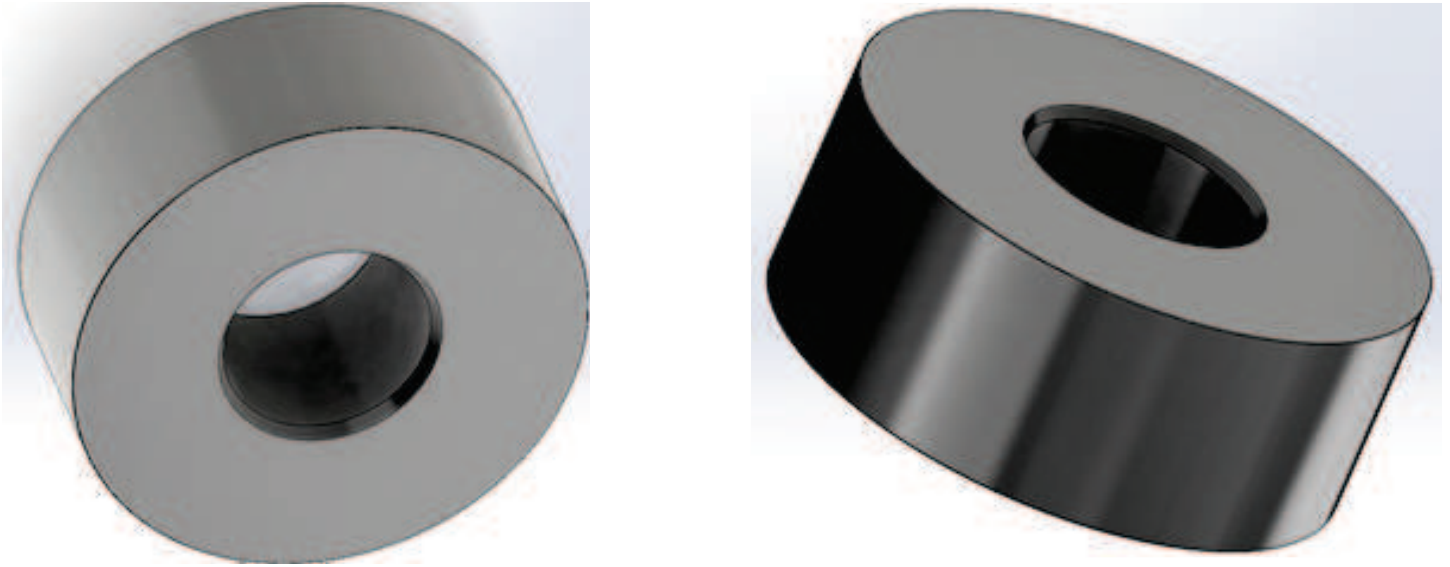

**Figure: 7**

Spacers are aluminum inserts that can be used in combination with the standard load cap, long load cap and extensions. The aluminum spacers come in thicknesses of 1", 2" and 3" to expand the flexibility of your lifting jack. However, there are limitations to the use of the spacers in lifting applications.

Refer to Figure 11 for the appropriate placement of the spacer.

**NOTE: Never use more than one spacer in any lifting jack configuration. See Table 2 for combinations of spacers and extensions by rail jack model.**

## EXTENSIONS

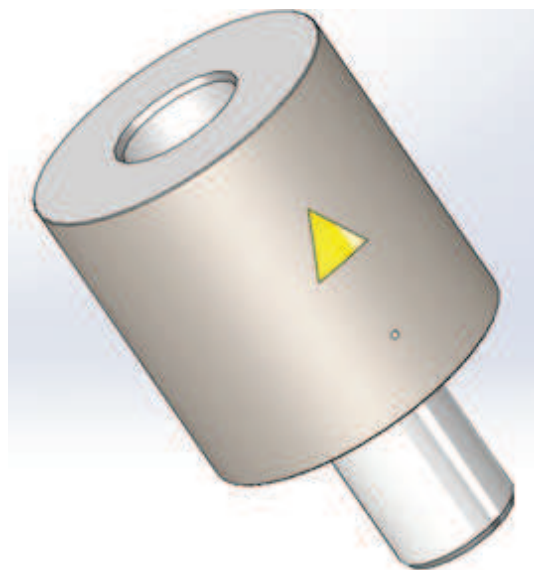

**Figure: 8**

While the stroke length of the jacking cylinder is dependent upon jack model, the use of extensions will increase the maximum lift “height” each jack will achieve. When increasing the lift height by using extensions, it is extremely important to:

1. Use a single extension per jack and do not exceed the maximum additional extension height by model See Table 2.
2. Confirm that the load is centered and evenly distributed on the load cap of the jack.
3. Confirm that the jack base is 100% supported.
4. Confirm that the load is restrained from moving in any direction other than the lift direction.

**See Table 2 for extension application. Do not use more than one application at a time, by itself or with one spacer.**

## CRIB BLOCKS

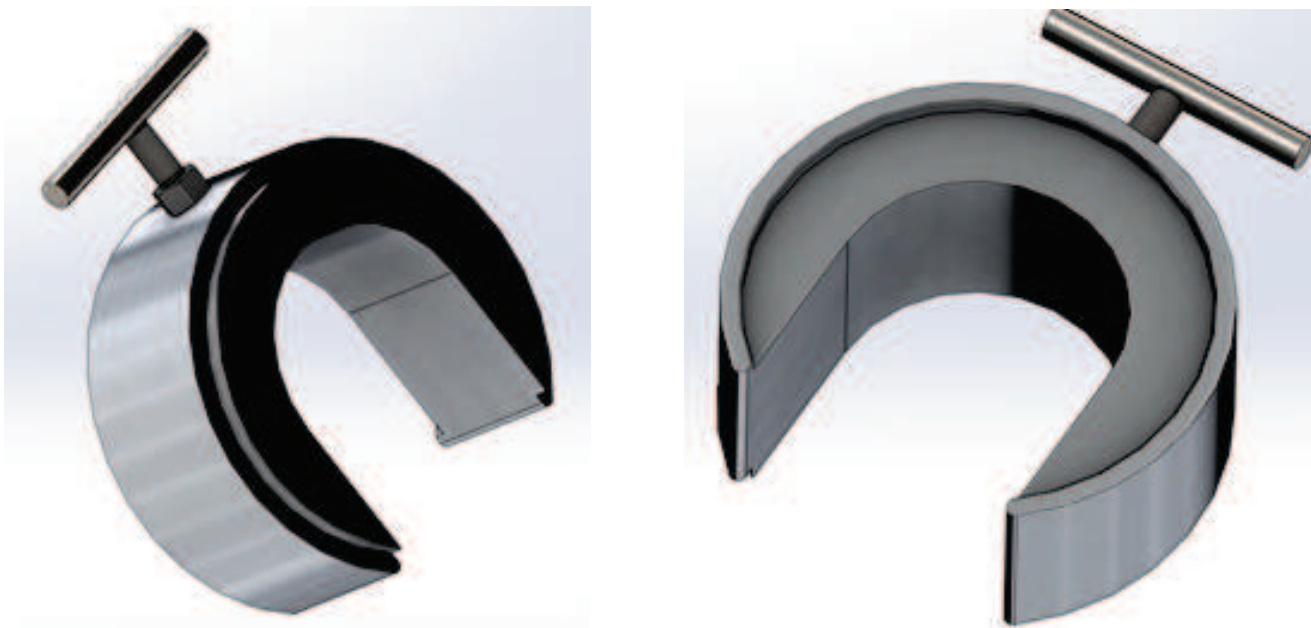
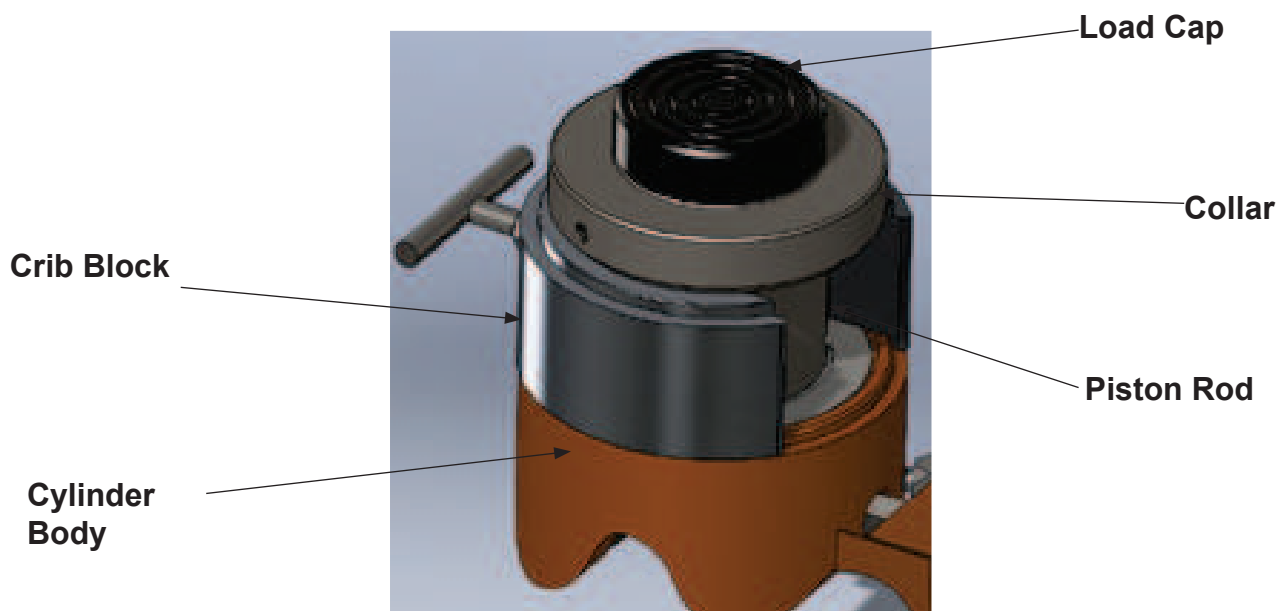

**Figure: 9**

Crib blocks may be used to assist in mechanically supporting the load as it is being raised. (See table 1 for the various Crib Block sizes).

During the lift, the pendant push button is depressed to advance the cylinder piston rod. Once the rod has extended high enough to accept the selected Crib Block, release the push button to stop the cylinder movement. For SAFETY, sufficient time should be given to allow the cylinder piston rod to settle and stop movement before attempting to slide the crib block onto the piston rod. (See Figure 9). NOTE PROPER ORIENTATION OF THE CRIB BLOCK TO ATTAIN CORRECT SEATING.

**!WARNING: Safety is paramount. This manual covers the general operation of the lifting jack. Each lift has its own variable conditions and this manual cannot cover all of those conditions. It provides general guidelines for safe operation of the lifting jack. It is the responsibility of the lifting jack operator to plan the appropriate steps of the lift and to determine if, along with crib blocks, additional mechanical supports are required during the specific lift in order to safely complete the lift. Failure to comply may result in extreme property damage, serious injury or death.**



**Figure: 10**

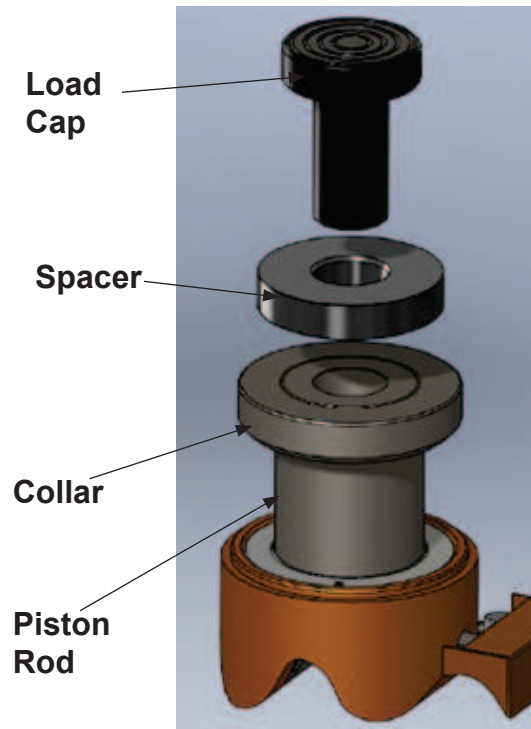
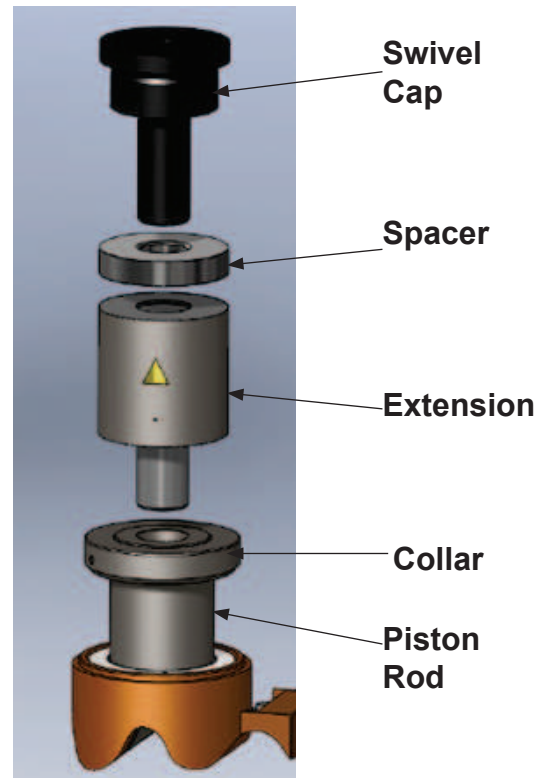

Figure: 11



### SWIVEL CAPS

#### RJ-SC-1 Swivel Cap Short



#### RJ-SC-2 Swivel Cap, Long

Figure: 12

When lifting a load, the load surface contacting the load cap must be parallel to the jack base supporting surface within 2.5°. Under this condition swivel caps can be used to provide better surface contact area with the load surface.

The short swivel cap, RJ-SC-1, can be used directly with the piston rod, or a single extension or with the one inch spacer.

The long swivel cap, RJ-SC-2, can be used directly with the piston rod, or the 1", 2" or 3" spacer. (NOTE: NEVER USE MORE THAN ONE SPACER AT A TIME AND NEVER COMBINE MORE THAN ONE SPACER WITH ONE EXTENSION AT A TIME).

# PORTABLE JACK HYDRAULIC CYLINDERS

All cylinders are marked with maximum pressure setting

These instructions are written to help you, the user, more effectively use and maintain your cylinders. If any questions, please call your nearest Power Team facility.

NOTE: For a detailed parts list or to locate a Power Team Authorized Hydraulic Service Center, contact your nearest Power Team facility. A list of all Power Team facilities is located at the end of this document.

Some of the information included in these instructions was selected from A.N.S.I. B30.1 and applies to the construction, installation, operation, inspection and maintenance of hydraulic cylinders. It is strongly recommended that you read A.N.S.I. B30.1 to answer any questions not covered in these instructions. The complete A.N.S.I. B30.1 standard which contains additional information can be obtained at a nominal cost from the American Society of Mechanical Engineers, United Engineering Center, 345 East 47th, New York, New York 10017.

## PREVENTIVE MAINTENANCE



### WARNING

To help prevent personal injury,



- Disconnect the pump from the power supply before performing maintenance or repair procedures.
- Repairs and maintenance are to be performed in a dust-free area by a qualified technician.

### 1. Hydraulic Fluid Level

- A. Check the oil level in the reservoir after each 10 hours of use. Proper oil level is 1/2" from the top of the fill hole when all cylinders are retracted.
- B. Drain, flush, and refill the reservoir with an approved, high-grade hydraulic oil after approximately every 300 hours of use. The frequency of oil changes will depend upon the general working conditions, severity of use, and overall cleanliness and care given the pump.

### 2. Lubrication (Air Driven Motor Only)

If the pump is operated on a continuous duty cycle or a maximum speeds for extended periods, an automatic air line oiler should be installed in the air inlet line as close to the pumping unit as possible. Set the unit to feed 1-3 drops of oil per minute (one drop for every 50-75 CFM of air) into the system, or refer to the pump manufacturer's instructions. Use SAE No. 10 oil.

### 3. Maintenance Cleaning

- A. Keep the pump's outer surface as free from dirt as possible.
- B. Seal all unused couplers with thread protectors.
- C. Keep all hose connections free of dirt and grime.
- D. The breather-hole in the filler cap must be clean and unobstructed at all times.
- E. Equipment connected to the pump must be kept clean.
- F. Use only an approved, high-grade hydraulic oil in this pump. Change as recommended (every 300 hours).

## 4. Draining And Flushing The Reservoir

**Note:** Clean the pump exterior before the pump interior is removed from the reservoir.

- A. Remove the ten screws fastening the motor and pump assembly to the reservoir.

**Note:** Do not damage the gasket or pump the filter or pressure regulating valves when lifting the pump and motor off the reservoir. See Figure 13.

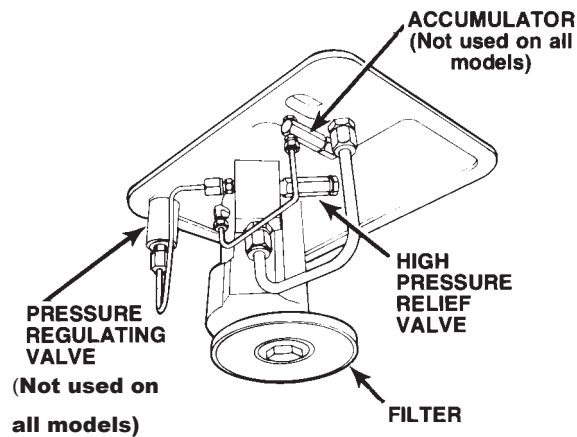

FIGURE 13

- B. Clean the inside of the reservoir and fill with a suitable flushing oil. Rinse the filter clean.
- C. Place the pump and motor assembly back onto the reservoir, and secure with two machine screws assembled on opposite corners of the housing.

**Note:** The pump is equipped with a valve that has only an advance or retract position, Place the valve in the advance position, and connect a hose to the advance port on the valve. Place the other end of the hose into the oil filler plug hole.

- D. Run the pump for several minutes. Then disconnect the motor and pump assembly, and drain and clean the inside of the reservoir.
- E. Fill the reservoir with an approved, high-grade hydraulic oil. Place the pump and motor assembly (with gasket) on the reservoir, and thread the ten screws. Tighten securely and evenly.

## 5. Adding Oil To The Reservoir

- A. Cylinder must be fully retracted and the power supply disconnected when adding oil to the reservoir.
- B. Clean the entire area around the filler plug before removing the filler plug.
- C. Use a clean funnel with filter when adding oil.
- D. Use an approved, high-grade hydraulic oil (215 SSU @ 100° F) only.



# PREVENTIVE MAINTENANCE (CONT.)

## 6. Checking Brushes On Universal Motors

To help prevent premature failure of the armature, check the brushes periodically.

- A. Remove the metal brush cover plates.
- B. Remove the brush holder caps and brush assemblies
- C. The brush assemblies must be replaced if they are 1/8" long or less. See Figure 14
- D. Install brush assemblies, brush holder caps, and metal brush cover plates. See Figure 15

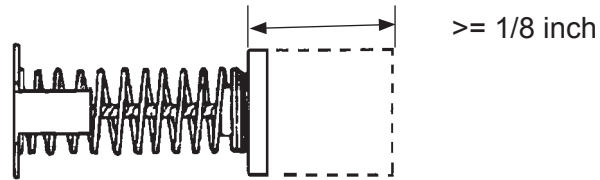
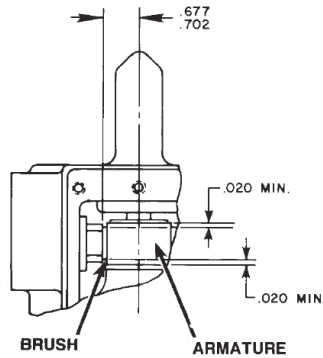

FIGURE 14 (Brush Assembly)

## REASSEMBLY SPECIFICATIONS



When replacing brushes or the armature, the dimensions shown must be as specified.

Figure 15 (Motor Brush Assembly)

## OPERATION

The counterbalance valves incorporate the holding associated with a Pilot Operated Check Valve and the control of a Pilot Operated Control Valve. The load will stop moving the moment the supply pump is stopped or the control valve is shifted to neutral. What all this means to you, the user, is that when using the valves in a system the following features are in place:

1. When lifting a load with a double-acting cylinder and a counter balance valve in the system - The return oil is checked at the valve by an internal pilot operated check valve. If a hose(s) from the pump to the valve is broken, the load will remain positively supported by this internal pilot operated check valve.
2. When lowering a load with a counter balance valve in the system - The operator will simply shift the pump-mounted, 4-way valve to the retract position. This begins the supply of oil under pressure to the top port/pilot line to the cylinder. When pressure in the pilot line reaches approximately 2000 PSI the pilot valve begins to open. Oil flows through the pilot operated flow control past the open pilot operated check back to the pump reservoir.

**NOTE: Pilot pressure could reach 4,000 PSI in light load applications at higher flow rates.**

## CONNECTING THE COUNTER BALANCE VALVE IN A SYSTEM

- Connect the RETRACT port from your pump-mounted valve and tee into port marked PILOT.
- The port marked PILOT should tee into the top (or retract) port of the cylinder.
- Connect the port marked CYL. BASE to the bottom (or advance) port of the cylinder.
- Connect the PUMP ADVANCE port from your pump-mounted valve to the port marked PUMP ADVANCE.

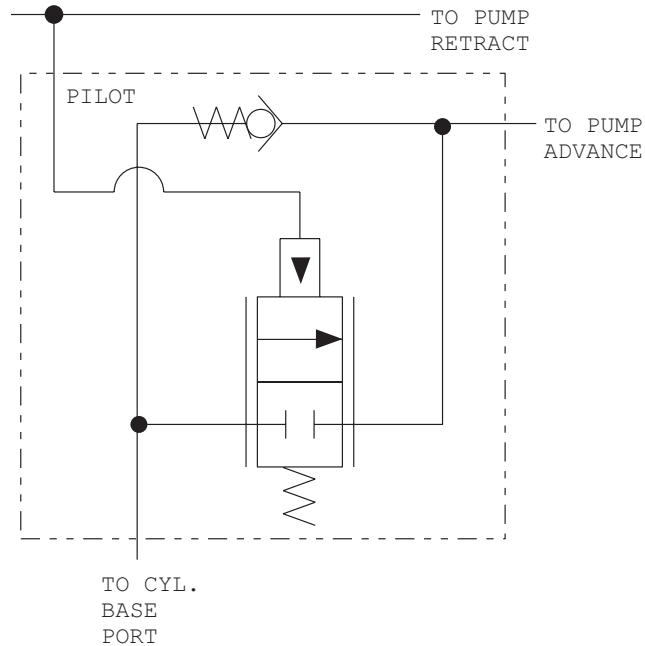

Figure 16

## HYDRAULIC SCHEMATIC

**Note: Before operating the system under load, bleed the system of all air, failure to completely bleed air from the system will result in erratic control during the load lowering sequence.**

## TROUBLE-SHOOTING GUIDE

**Note: The following trouble-shooting and repair procedures should be performed by qualified personnel familiar with this equipment. Use the proper equipment when trouble-shooting!**

PROBLEM	CAUSE	SOLUTION
<b>Electric motor does not run</b>	1. Pump not turned ON.	1. Flip toggle switch to "Run" position.
	2. Unit is not plugged in.	2. Plug in unit.
	3. No voltage supply.	3. Check line voltage. Check reset button on power panel.
	4. Broken lead wire or defective power cord plug.	4. Replace defective parts.
	5. Defective switches.	5. Check switches.
	6. Defective motor.	6. Repair or replace motor.
	7. Defective starter relay.	7. Replace defective parts.
	8. Defective remote switch.	8. Repair or replace remote switch.
	9. Worn brushes	9. Replace brushes
	10. Circuit breaker tripped because total amperage draw too high for existing circuit.	10. Add an additional circuit or use alternate circuit.
	11. Overheated motor (single-phase motor only). Magnetic starter disengaged (three-phase motor only). Thermal protector open.	11. Wait for motor to cool before restarting. Reset thermal protector (Single-phase motor will reset automatically.)
	12. Faulty thermal protector (single-phase motor). Faulty magnetic starter (three-phase motor).	12. Replace



### **WARNING**

**To help prevent personal injury, disconnect power supply before removing cover. Any electrical work should be performed by a qualified electrician.**

PROBLEM	CAUSE	SOLUTION
<b>Pump is not delivering oil or delivers only enough oil to advance cylinder(s) partially or erratically.</b>	1. Oil level too low.	1. Fill reservoir to 1/2" from top of filler hole with all cylinders retracted.
	2. Loose-fitting coupler to cylinder.	2. Check quick-disconnect couplings to cylinders. Inspect couplers to ensure that they are completely coupled. Occasionally couplers have to be replaced because the ball check does not stay open due to wear.
	3. Air in system.	3. Bleed the system
	4. Air leak in suction line.	4. Check and tighten suction line.
	5. Dirt in pump or filter plugged.	5. Pump filter should be cleaned and, if necessary, pump should be dismantled and all parts inspected and cleaned.
	6. Oil is bypassing through the double-acting cylinder.	6. Be removing the cylinder and capping the hoses, the pump and valve can be checked. Observe if pump holds pressure.
	7. Cold oil or oil too heavy (Hydraulic oil is of a higher viscosity than necessary).	7. Change to a lighter oil.
	8. Relief valve or low pressure unloading valve out of adjustment.	8. Adjust as needed.
	9. Reservoir capacity is too small for the size of the cylinder(s) used.	9. Use smaller cylinder(s) or larger reservoir.
	10. Defective directional valve.	10. Inspect all parts carefully and replace if necessary.
	11. Sheared drive shaft key(s).	11. Replace.
	12. Motor rotating in wrong direction.	12. 3450 RPM motor: Refer to electrical schematic on motor. 12,000 RPM motor: Reverse lead wires to brush holders. Air motor: Air line connected into wrong port.
	13. Vacuum in reservoir.	13. Check for plugged vent in filler plug.
	14. Low pressure pump worn	14. Remove end cap from low pressure gear pump . Clean pump, and replace worn gears, shifting spool, body or end cap.

# TROUBLE-SHOOTING (CONT.)

PROBLEM	CAUSE	SOLUTION
<b>Pump builds pressure but cannot maintain pressure.</b>	<ol style="list-style-type: none"> <li>1. Check to see if there are any external leaks. If no oil leakage is visible, the problem is internal. If using a double-acting cylinder, remove it from the system to ensure that the leak is not in the cylinder.</li> <li>2. To test for a leaking control valve, lift the pump from the reservoir but keep the filter in the oil. Remove the drain line to see if the oil is leaking from the valve. If the valve is not leaking, the internal check valve could be leaking. Refer to the note concerning checking for oil leaks at the beginning of this Troubleshooting Guide.</li> <li>3. Leaking pressure switch seal.</li> </ol>	<ol style="list-style-type: none"> <li>1. Seal leaking pipe fittings with pipe sealant.</li> <li>2. Clean, reseal or replace flow control valve parts. If the internal check valve(s) are leaking, the pump must be dismantled and the seat areas repaired, poppets replaced, etc.</li> <li>3. Repair or replace seal.</li> </ol>
<b>Pump will not build full pressure.</b>	<ol style="list-style-type: none"> <li>1. Faulty pressure gauge.</li> <li>2. Check for external leakage.</li> <li>3. Check the external pressure regulator. Check the relief valve setting.</li> <li>4. Look for internal leakage in double-acting cylinders.</li> <li>5. Check for leaks in the flow control valve.</li> </ol>	<ol style="list-style-type: none"> <li>1. Calibrate gauge.</li> <li>2. Seal faulty pipe fitting with pipe sealant.</li> <li>3. Lift the pump from the reservoir, but keep the filter immersed in oil. Note the pressure reading when the relief valve begins to open. If functioning normally, it should start to leak off at relief valve pressure.</li> <li>4. Remove the cylinder from the pump. If the pump builds full pressure, the cylinder is defective.</li> <li>5. Clean and reseal or replace parts.</li> </ol>

PROBLEM	CAUSE	SOLUTION
<b>Pump will not build full pressure. (Continued)</b>	6. Inspect the pump for internal leakage. Check high pressure pump inlet or outlet ball checks.	6. Same procedure as above, but look for leaks around the entire inner mechanism. If there are no visible leaks, the high pressure pump sub-assembly may be leaking. Remove all parts. Check the valve head assembly body for any damage to the sea area. Clean and reseal if necessary. Inspect for damage and replace if necessary, then reassemble.
	7. Sheared key(s).	7. Replace
	8. Inadequate air pressure (air motor only).	8. Increase air pressure.
	9. Shifting spool seat and/or shifting spool poppet (located under high pressure pump assembly) worn.	9. Clean and reseal or replace.
	10. Shifting spool O-ring (located within shifting spool bore) worn or broken.	10. With an O-ring pick, remove O-ring and backup washer through low pressure pump assembly end. Replace.
<b>Cylinder(s) will not retract.</b>	1. Check the system pressure; if the pressure is zero, the control valve is releasing pressure and the problem may be in the cylinder(s), mechanical linkage connected to cylinder(s), or quick-disconnect couplings	1. Check the cylinder for broken return springs, and check couplers to ensure that they are completely coupled. Occasionally couplers have to be replaced because one check does not stay open in the coupled position.
	2. Defective valve.	2. Check valve operation and inspect parts. Replace if necessary.
	3. Inadequate air pressure (air motor model only).	3. Increase air pressure.
<b>Pump delivers excess oil pressure.</b>	1. Faulty pressure gauge.	1. Calibrate gauge.
	2. Relief valve not properly set.	2. Adjust the relief valve.
<b>Gasoline engine</b>		1. Refer to instruction manual included with gasoline engine.

# TROUBLE-SHOOTING (CONT.)

PROBLEM	CAUSE	SOLUTION
<b>Erratic action</b>	1. Air in system or pump cavitation	1. Add fluid, bleed air and check for leaks
	2. Internal leakage in cylinders	2. Replace worn packings. Check for excessive contamination or wear. Replace contaminated fluid as necessary.
	3. Cylinder or valve sticking or binding	3. Check for dirt or leaks. Check for bent, misaligned, worn parts or defective packings. Replace contaminated hydraulic oil with clean, compatible hydraulic oil.
	4. Malfunctioning valve	4. Replace. This valve is <u>NOT</u> serviceable.
<b>Cylinder/Ram does not move</b>	1. Loose couplers	1. Tighten couplers
	2. Faulty coupler	2. Verify coupler is not locked up. Replace as needed.
	3. Improper valve position	3. Close release valve or shift to new position
	4. Low or no hydraulic fluid in pump reservoir	4. Fill and bleed the system
	5. Air-locked pump	5. Prime pump per pump operating instructions
	6. Pump not operating	6. Check pump's operating instructions
	7. Load is above the capacity of the system	7. Use the correct equipment
	8. Fluid leaks out of rod end relief valve	8. Make sure all couplers are fully coupled. Contact your nearest Authorized Hydraulic Service Center.
	9. No pilot pressure to valve	9. Check connections, pump valve position, and pressure.
	10. Malfunctioning valve	10. Replace. This valve is <u>NOT</u> serviceable.
<b>Cylinder/Ram extends only partially</b>	1. Pump reservoir is low on hydraulic fluid	1. Fill and bleed the system
	2. Load is above the capacity of the system	2. Use the correct equipment
	3. Cylinder piston rod binding	3. Check for dirt or leaks. Check for bent, misaligned, worn parts or defective packings.

PROBLEM	CAUSE	SOLUTION
<b>Cylinder/Ram moves slower than normal</b>	<ol style="list-style-type: none"> <li>1. Loose connection or coupler</li> <li>2. Restricted hydraulic line or fitting</li> <li>3. Pump not working correctly</li> <li>4. Cylinder seals leaking</li> </ol>	<ol style="list-style-type: none"> <li>1. Tighten</li> <li>2. Clean and replace if damaged</li> <li>3. Check pump operating instructions</li> <li>4. Replace worn seals. Check for excessive contamination or wear</li> </ol>
<b>Cylinder/Ram moves but does not maintain pressure</b>	<ol style="list-style-type: none"> <li>1. Leaky connection</li> <li>2. Cylinder seals leaking</li> <li>3. Pump or valve malfunctioning</li> </ol>	<ol style="list-style-type: none"> <li>1. Clean, reseal with thread sealant and tighten connection</li> <li>2. Replace worn seals. Check for excessive contamination or wear. Replace contaminated fluid as necessary.</li> <li>3. Check pump or valve operating instructions</li> </ol>
<b>Cylinder/Ram leaks hydraulic fluid</b>	<ol style="list-style-type: none"> <li>1. Worn or damaged seals</li> <li>2. Loose connections</li> <li>3. Rod end relief valve has activated</li> </ol>	<ol style="list-style-type: none"> <li>1. Replace worn seals. Check for excessive contamination or wear. Replace contaminated fluid as necessary.</li> <li>2. Clean, reseal with thread sealant and tighten connection</li> <li>3. Make sure all couplers are fully coupled.               <ol style="list-style-type: none"> <li>a. If relief valve is still leaking, do not attempt to service this component. Contact your nearest Authorized Hydraulic Service Center.</li> </ol> </li> </ol>
<b>Cylinder/Ram will not retract or retracts slower than normal</b>	<ol style="list-style-type: none"> <li>1. Pump release valve closed</li> <li>2. Loose couplers</li> <li>3. Blocked hydraulic lines</li> <li>4. Cylinder damaged internally</li> <li>5. Pump reservoir too full</li> <li>6. Pump or valve malfunctioning</li> </ol>	<ol style="list-style-type: none"> <li>1. Open pump release valve</li> <li>2. Tighten couplers</li> <li>3. Clean and flush</li> <li>4. Send to service center for repair</li> <li>5. Drain hydraulic fluid to correct level</li> <li>6. Check pump or valve operating instructions</li> </ol>