

Clutch/Brake UniModule UM-50, UM-100, UM-180

Service & Installation Instructions

P-273-4-WE
819-0528



Vented



Enclosed Version Optional

Contents

Mounting to a C-Face Motor	3
Mounting to a Reducer.	4
Installing the Base Mount	4
Installing the Motor Mount Bracket.	5
Mounting to Other Power Transmission Components.	5
Electrical Connections	6
Troubleshooting-Electrical	6
Troubleshooting-Mechanical.	6
Enclosed UniModule Option.	8
Warranty.	BC

⚠ WARNING Failure to follow these instructions may result in product damage, equipment damage, and serious or fatal injury to personnel.

⚠ WARNING The equipment covered by this installation manual must be installed in accordance with these instructions. Failure to do so may damage the equipment and void the warranty.

Warner Electric UniModules are designed to National Electrical Manufacturers Association (NEMA) standards. They can be mounted to common NEMA C-Face motors and reducers as well as common power transmission drive components.

The 1020 and 1040 UniModules are designed to mount to the face of a C-Face motor as noted in Table 1.

Corresponding NEMA Frame Sizes

UM Size	Old NEMA	New NEMA	Shaft Dia.	C-Face Pilot Dia.
50	56 C	48 Y	5/8"	4-1/2"
100	56 C	48 Y	5/8"	4-1/2"
180	182 C	143 TC	7/8"	4-1/2"
	184 C	145 TC		

Table 1

The 2030 and 3040 UniModules are designed to mount using a base mounting kit. This allows the modules to be mounted as a separate drive unit driven from the prime mover by V-belts, chain and sprockets, couplings, timing belts and other standard power transmission components.

(For UniModule sizes 210 and 215 please refer to Warner Electric manual P-273-1)

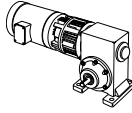
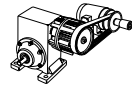
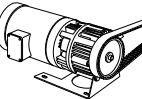
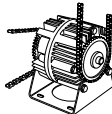
For These UM Combinations	Use These Installation Steps:
 UniModule Clutch/Brake between C-Face Motor and Reducer - 1020 UniModule Clutch between Motor and Reducer - 1040	Mounting to a Motor Mounting to a Reducer Electrical Connections
 UniModule Clutch/Brake - 2030 UniModule Clutch - 3040	Mounting to other Power Transmission Components Electrical Connections
 Motor Mount Module Clutch/Brake on a C-Face Motor - 1020-M Motor Mount UniModule Clutch on a C-Face Motor - 1040-M	Mounting to a Motor Installing the Motor Mount Bracket Mounting to other Power Transmission Components Electrical Connections
 Base Mounted UniModule Clutch/Brake - 2030-B UniModule Clutch - 3040-B	Installing the Base Mount Mounting to other Power Transmission Components Electrical Connections

Install your specific UniModule combination according to the installation steps specified in the table. Use only those steps indicated for each combination.

Mounting to a C-Face Motor

1. A hardened key is provided with the mounting hardware for UniModules. Insert this key onto the motor shaft. It is recommended to stake the end of the motor shaft keyway to keep the key from moving out during operation.
2. Align the keyway in the bore of the UniModule to the key in the motor shaft and slide the unit onto the motor shaft. The normal alignment of the module to the motor will be with the wire exit/conduit box in the upright (12 o'clock) position as shown in Figure 1.

⚠ WARNING Do not hammer or force the module into position. To do so may damage bearings or cause the friction faces to shift out of alignment.



Figure 1

⚠ CAUTION If anti-fretting lubricant is used on the motor shaft for future ease of removal, ensure that any excess is wiped off before unit assembly to avoid lubricant contaminating the clutch or brake friction faces.

3. Secure the UniModule to the motor with the four (4) long mounting tie-bolts provided. Tighten the four (4) bolts alternately to ensure even alignment of the module. Tighten them to 30-35 foot pounds.

⚠ WARNING Do not tighten the two (2) clutch rotor set screws to the shaft before tightening the four (4) module tie-bolts. This could cause a preload on the pilot bearing resulting in premature bearing failure.

4. Next secure the clutch rotor and fan assembly to the motor shaft by tightening the two (2) setscrew as follows:
 - a. There are two (2) access slots on either side of the UniModule. A long Allen wrench can be used to tighten the two setscrews (90° apart) which secure the clutch rotor and fan assembly to the motor shaft.
 - b. Alternately align each setscrew with one of the access slots by rotating the clutch rotor and fan assembly through one of the side vents with a small screw driver taking care not to damage the fan. (Figure 2a)

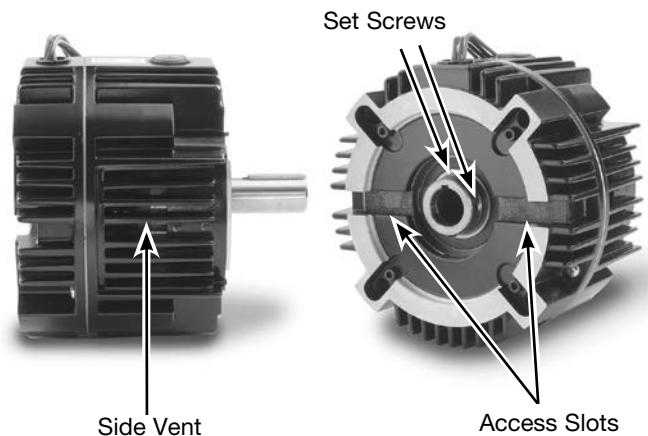

Figure 2a

- c. Using a torque wrench and long Allen socket, tighten the two (2) setscrews to: (Figure 2b)
 - Size 50: 80-85 inch pounds
(Requires 5/32 inch Allen wrench)
 - Size 100 or 180: 40-45 inch pounds
(Requires 1/8 inch Allen wrench)



Figure 2b

Mounting to a Reducer

1. Warner Electric UniModules are furnished with a hardened key pre-mounted on the output shaft.
2. Align the output shaft and key of the module with the corresponding bore and keyway of the reducer. Slide the assembly together as shown in Figure 3.



Figure 3

3. Bolt the module to the reducer flange. The four (4) bolts that are required (3/8-16UNC2A) are typically provided with the reducer. Tighten to 18-22 foot pounds of torque.

Installing the Base Mount

Model 2030 and 3040 UniModules are designed to be base mounted as shown in Figure 4.



Figure 4

Optional Base Mount Kit,
Warner Electric part numbers:

UM-50/100.....	5370-101-004
UM-180.....	5370-101-002

1. The pilot diameters on each end of the UniModule will mate with the pilot diameters on the base.
2. Secure the base to the UniModule with the four (4) bolts provided. Tighten to 18 to 22 foot pounds.

Installing the Motor Mount Bracket

A Motor Mount Bracket can be installed on the output end of a 1020 and 1040 UniModule to provide a foot mounting for the complete assembly of a UniModule and C-face motor.

Optional Motor Mount Kit,

Warner Electric part numbers:

UM-50/100.....5370-101-078

UM-180.....5370-101-079

1. Mount the bracket to the face of the UniModule underneath the UniModule and motor as shown in Figure 5. A pilot diameter on the UniModule mates with a pilot diameter on the bracket.



Figure 5

2. Secure the motor bracket in place with four (4) short bolts and washers provided. Tighten to 18 to 22 foot pounds.

Mounting to Other Power Transmission Components

Couplings, pulleys, sprockets or similar power transmission components can be mounted to the input and output shafts of a UniModule.

CAUTION When mounting a pulley or sprocket, ensure that the key is fully engaged within the device hub or bushing.

CAUTION Confirm that the belt or chain tightness meets the maximum side load capability of the UniModule shown in Table 2.

Overhung Load Data (Shaft Side Load)

Overhung load data is provided in this manual for the design engineer concerned with a specific problem in this area. The maximum allowable overhung load which can be applied to the shaft of an UniModule may be determined by the use of the accompanying chart.

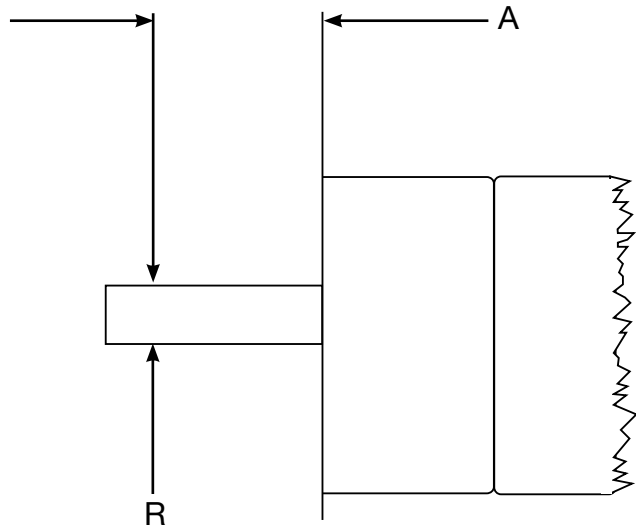

Distance Load is Applied from

UniModule	Housing Face "A" Inches	Maximum Load Rating "R" Lbs.
UM-50	1" (Center of Shaft)	177
	2" (End of Shaft)	123
	3"	95
UM-100	1" (Center of Shaft)	192
	2" (End of Shaft)	134
	3"	104
UM-180	1" (Center of Shaft)	192
	2" (End of Shaft)	134
	3"	104

Table 2

Electrical Connections

⚠ WARNING To avoid injury (or even death), always make certain all power is off before attempting to install or service this device or any electrical equipment.

Warner Electric UniModules are provided with a conduit hole threaded for a standard 1/2 inch conduit connection. Both the clutch and brake lead wires exit this opening. If a Conduit Box is desired, Warner Electric Conduit Box Kit, part number: 5370-101-042, can be purchased separately. The Conduit Box provides two conduit connection holes for standard 1/2 inch conduit connectors.

UniModule clutches and clutch/brakes operate on DC voltage. Warner Electric offers a complete line of electronic controls to meet the needs of almost any clutch or clutch/brake application. Each Warner Electric control will show the proper wiring connections for its use.

Troubleshooting - Electrical



Scan to Watch Clutch & Brake
Electrical Troubleshooting Video
<https://p.widencdn.net/byvbd>

A UniModule that is not functioning properly may be caused by other problems. It is best to check for these problems before replacing it.

A UniModule requires DC power to function. If power is not reaching the clutch or brake, they will not engage.

A good practice to follow is to check for power at the lead wires to the clutch or brake using a voltmeter.

- If power is present in the proper voltage and current (see Electrical Coil data), then skip ahead to the Mechanical Troubleshooting section.
- If power is not present, inspect the lead wires for breaks or cuts.
- If the wires are intact, the problem may be with the power supply or the switch.

- Using a voltmeter, check to see that proper DC voltage is leaving the power supply and that the switch is sending power to the clutch or brake.
- Finally, if there is no power leaving the switch or power supply, check the incoming AC power to ensure that it is reaching the power supply.

Electrical Coil Data

		Clutch	Brake	Clutch	Brake	Clutch	Brake
Voltage-D.C.		90	90	24	24	6	6
Resistance	UM-50	452	429	31.8	28.8	1.9	1.9
(OHMS)	UM-100/180	392	392	26.7	26.7	1.8	1.8
Current	UM-50	.20	.21	.76	.83	3.2	3.2
(Amperes)	UM-100/180	.23	.23	.90	.90	3.3	3.3
Power	UM-50	18	19	19	20	20	20
(WATTS)	UM-100/180	21	21	22	22	20	20
Coil Build Up	UM-50	52	53	52	53	52	53
Time (ms)	UM-100/180	72	75	72	75	72	70
Coil Decay	UM-50	6	5	6	5	6	5
Time (ms)	UM-100/180	12	10	12	10	12	10

Troubleshooting - Mechanical



Scan to Watch
Airgap Adjustment Video
<https://p.widencdn.net/dg6idh>

Both clutch and brake armatures are equipped with an Autogap™ assembly that maintains the proper airgap between friction faces through the life of the product. Each UniModule is airgap adjusted and pre-burnished at the factory, but the airgaps can shift as a result of rough handling during shipping and installation.

An airgap that is too large can prevent the armature from engaging. An airgap that is too small can cause the armature to rub continuously, causing higher running temperatures and decreased wear life.

To reset the airgaps, you will need to access the armatures. Looking through the vents on either side of the housing, you will see the fan on the clutch rotor. Rotate the fan (input) until you see the 1/2 x 1 inch window on the outer periphery of the fan.

Through this window, you will be looking between the two armatures of the clutch and brake. (Figures 6 & 7)

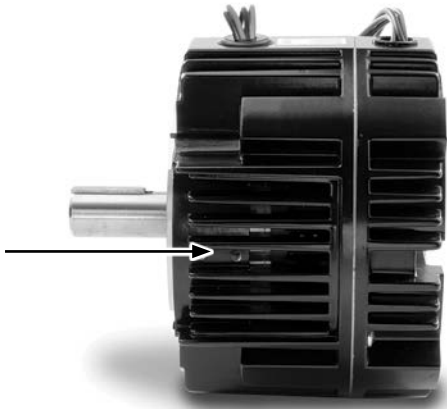

Figure 6

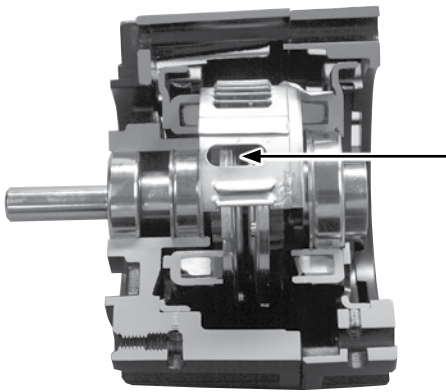

Figure 7

If either armature is too far away from its mating friction surface, it is possible to move it back into adjustment using a flat blade screwdriver. (Figure 8)

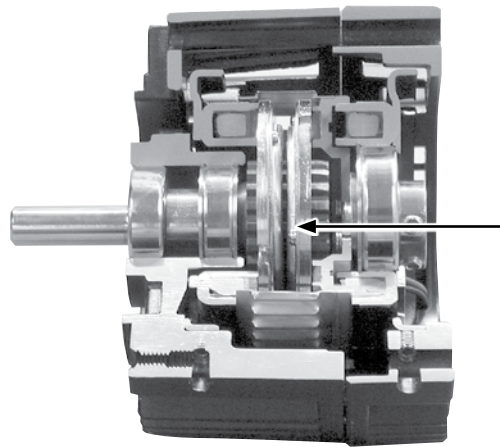

Figure 8

Note: When resetting the clutch or FB brake armature airgap, both the clutch and brake must be released (the brake energized, and the clutch not energized).

This is a three step process.

1. Simply slide the screwdriver through the window. By twisting the screwdriver, it works as a wedge to apply pressure on the back of the armature pushing it toward its mating friction surface.
2. Rotate the output of the unit. The rotor and window should stay in place when you do this. Only the armatures will move.
3. Alternately repeat steps 1 & 2 to ensure that the airgap between the armature and its mating surface is about 1/32 inch and that the armature remains square to its mating surface. (If the armature is uneven, it may engage on just one side giving the appearance of engagement but failing to provide full torque.)

If there is a scraping or rubbing sound when the output shaft is rotated, this means that an armature is dragging and is too close to its mating surface. Simply repeat steps 1-3 above, but place the screwdriver between the face of the armature and its mating friction surface.

Note: If you have a Smooth Start UniModule it is similar to a standard UniModule except Autogaps™ are eliminated from the armatures and a compression spring is inserted between the armatures. This results in the armatures being in continuous contact with the rotor and brake resulting in light, continuous drag. This arrangement eliminates the sudden change in torque that results when auto-gapped armatures engage.

No adjustment is required for the life of the unit unless it is jarred, resulting in the armature being moved away from the mating surface and cocking on the spline. If this occurs, a slight pry on the armature usually gets it back into position.

Mechanical Data

	UM-50	UM-100/180
Static Torque - lb. ft.	16	30
Maximum Speed - rpm	3600	3600
Average Weight - lbs.		
1020	15.6	18.7
1040	14.0	16.6
2030	18.4	21.7
3040	16.8	19.5

Inertia - WR - lb.ft.²

Configuration	50	100/180
1020 input	.021	.047
1020 output	.0195	.050
1040 input	.021	.047
1040 output	.0105	.027
2030 input	.021	.048
2030 output	.0195	.050
3040 input	.021	.048
3040 output	.0105	.027

Enclosed UniModule Option

Vented Warner Electric UniModules and base assemblies can be oriented as necessary to keep contaminants from entering the open housing vents.

If an Enclosed UniModule is required, an optional Cover Kit, Warner Electric part number 5370-101-076, can be purchased separately to enclose the open vents in the housing.

Each Cover Kit includes two (2) vent covers and four (4) screws needed to convert a vented UniModule to an enclosed design (non-washdown) as shown in Figure 9.



Figure 9

Note: When using this Cover Kit to enclose the module the vent covers should be assembled as the final step.



Scan to Watch
Cover Kits Video
<https://p.widencdn.net/xrhdf>

Notes:

Visit Warner Electric's website at www.warnerelectric.com for dimensional drawings, weights, inertias, and a complete offering of our products including clutches, brakes and clutch/brake controls and service parts.

In addition to Warner Electric module products, other package products, controls, and service parts information can be found in our Packaged Electromagnetic Clutches/Brakes Catalog Series:

- NEMA C-Face Compatible Clutches, Brakes & Clutch Brake Combinations Catalog P-8586-WE
- Shaft Mounted Clutches & Brakes Catalog P-8587-WE
- Base Mounted Clutch/Brake Combinations Catalog P-8588-WE
- Electrically Released Spring-Set Brakes & Unibrake AC Motor Brakes Catalog P-8589-WE
- Permanent Magnet Electrically Released Brakes Catalog P-8590-WE.

Call 815-389-3771 to request any of our catalogs.

Warranty

Warner Electric LLC warrants that it will repair or replace (whichever it deems advisable) any product manufactured and sold by it which proves to be defective in material or workmanship within a period of one (1) year from the date of original purchase for consumer, commercial or industrial use.

This warranty extends only to the original purchaser and is not transferable or assignable without Warner Electric LLC's prior consent.

Warranty service can be obtained in the U.S.A. by returning any defective product, transportation charges prepaid, to the appropriate Warner Electric LLC factory. Additional warranty information may be obtained by writing the Customer Satisfaction Department, Warner Electric LLC, 449 Gardner Street, South Beloit, Illinois 61080, or by calling 815-389-3771.

A purchase receipt or other proof of original purchase will be required before warranty service is rendered. If found defective under the terms of this warranty, repair or replacement will be made, without charge, together with a refund for transportation costs. If found not to be defective, you will be notified and, with your consent, the item will be repaired or replaced and returned to you at your expense.

This warranty covers normal use and does not cover damage or defect which results from alteration, accident, neglect, or improper installation, operation, or maintenance.

Some states do not allow limitation on how long an implied warranty lasts, so the above limitation may not apply to you.

Warner Electric LLC's obligation under this warranty is limited to the repair or replacement of the defective product and in no event shall Warner Electric LLC be liable for consequential, indirect, or incidental damages of any kind incurred by reason of the manufacture, sale or use of any defective product. Warner Electric LLC neither assumes nor authorizes any other person to give any other warranty or to assume any other obligation or liability on its behalf.

WITH RESPECT TO CONSUMER USE OF THE PRODUCT, ANY IMPLIED WARRANTIES WHICH THE CONSUMER MAY HAVE ARE LIMITED IN DURATION TO ONE YEAR FROM THE DATE OF ORIGINAL CONSUMER PURCHASE. WITH RESPECT TO COMMERCIAL AND INDUSTRIAL USES OF THE PRODUCT, THE FOREGOING WARRANTY IS IN LIEU OF AND EXCLUDES ALL OTHER WARRANTIES, WHETHER EXPRESSED OR IMPLIED BY OPERATION OF LAW OR OTHERWISE, INCLUDING, BUT NOT LIMITED TO, ANY IMPLIED WARRANTIES OF MERCHANTABILITY OR FITNESS.

Some states do not allow the exclusion or limitation of incidental or consequential damages, so the above limitation or exclusion may not apply to you. This warranty gives you specific legal rights and you may also have other rights which vary from state to state.

Changes in Dimensions and Specifications

All dimensions and specifications shown in Warner Electric catalogs are subject to change without notice. Weights do not include weight of boxing for shipment. Certified prints will be furnished without charge on request to Warner Electric.



www.warnerelectric.com

31 Industrial Park Road
New Hartford, CT 06057
815-389-3771