

UM Series UniModule

Sizes 50, 100, and 180

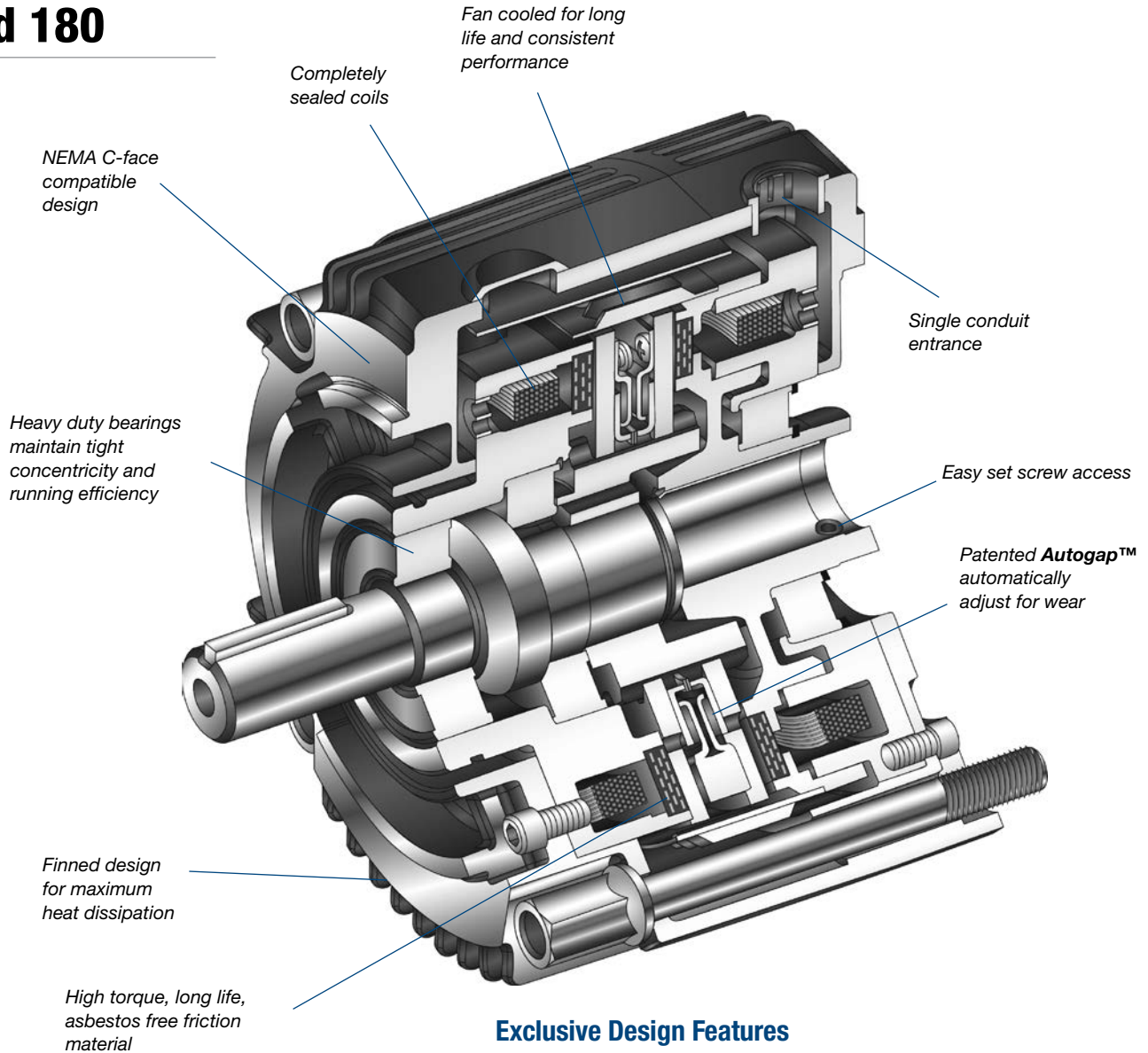

Exclusive Design Features

- Internal component changes make installation easier and faster
- Symmetric housing fin design increases heat dissipation capacity
- Available only in 50, 100, and 180 sizes, NEMA C-face design
- Conduit box relocation simplifies installation. Use of integrated mounting bolts allows for conduit box location directly on the top of the unit
- Available field installed conversion kit creates a totally enclosed clutch/brake package without the need to replace entire unit
- New design allows for more efficient assembly which yields greater availability and shorter lead times
- Improved input to output axis design reduces vibration and improves noise and wear factors
- Heavy-duty models available with increased spline length and higher load capacity bearings.



Sizes 210 and 215

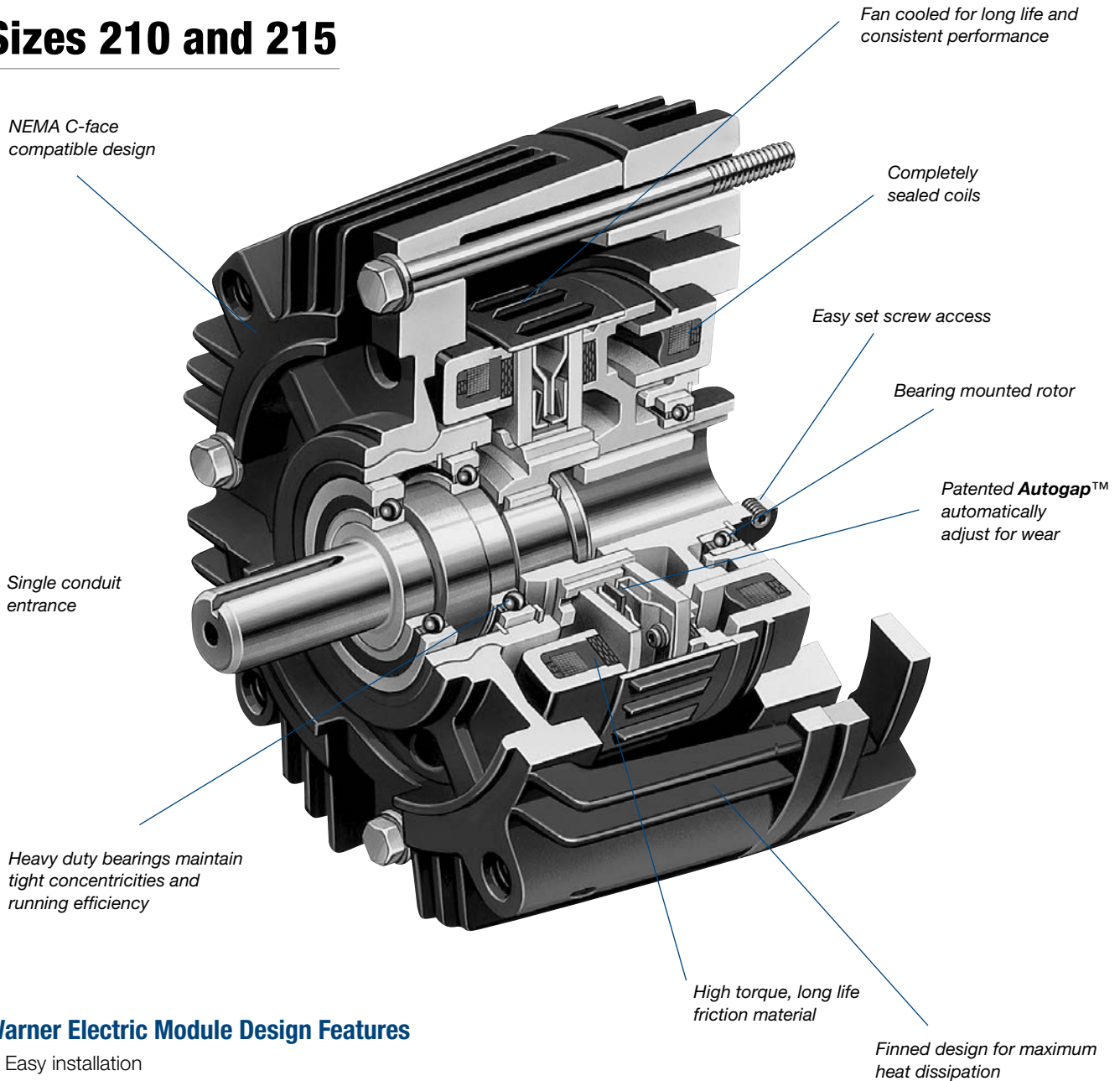

Warner Electric Module Design Features

- Easy installation
- Available with standard power-on and electrically released power-off brake units
- Fan cooled for high cycle rate operation
- Maintenance Free
- UL listed
- Can be applied with control fitted as standard
- Bearing mounted clutch rotor eases assembly alignment
- Single access hole for all wires

UM Series UniModule

Pre-assembled, C-face Clutches and Brakes

UniModules offer the ultimate in Clutch/ Brake performance and convenience. UniModules offer the same performance as EM's without the assembly required.

Completely pre-assembled one-piece clutch and clutch/brake packages in five sizes. Can be motor or reducer mounted or used as a separate drive unit powered by a prime mover.

Pre-assembled, pre-aligned, and pre-burnished at the factory for rated torque directly out-of-the-box.

- Easy installation
- Available with standard power-on and electrically released power-off brake units
- Fan cooled for high cycle rate operation
- Maintenance Free
- NEMA C-face design. Available in 50, 100, 180, 210, and 215 sizes.
- UL listed
- Can be applied with control fitted as standard
- Bearing mounted clutch rotor eases assembly alignment
- Single access hole for all wires



Sizes 50, 100 & 180

Sizes 210 & 215

UniModule Combinations

Clutch Combinations



1040

Motor Clutch/Output Clutch

Use for clutch only applications. Has hollow bore input for mounting directly to C-face motors. Shaft and C-face on output side of unit accommodates reducer, parallel drive or coupling. Motor Clutch is fan cooled for long life and consistent performance. Basic components are field, rotor and armature. See page A-27 in this catalog.



3040

Input Clutch/Output Clutch

Use for clutch only applications. Features dual C-faces and shafts. Unit input from parallel drive or coupling. Output to reducer. Input Clutch is fan cooled and has sealed coil. Twin bearing mounted shafts maintain tight concentricities. The Output Clutch utilizes Autogap™ which automatically adjusts armature for wear. Basic components are field, rotor and armature. See page A-29 in this catalog.



3040-B

Input Clutch/Output Clutch – with Accessory Base Mounting

Base mounting allows the clutch unit to be utilized as a separate drive unit. Attach with pulleys, sprockets, etc. See page A-29 in this catalog.

Clutch/Brake Combinations



1020

Motor Clutch/Brake

Use for clutch/brake applications. Has hollow bore input for mounting directly to C-face motors. Brake shaft and C-face on output side accommodate a reducer, parallel drive or coupling. Basic components: field, rotor, 2 armatures and power-on magnet. See page A-26 in this catalog.

Heavy-duty models available with increased spline length and higher load capacity bearings.

Smooth-Start Motor Clutch/Brake

See page A-30

Ceramic Faced Motor Clutch/Brake

See page A-37



2030

Input Clutch/Brake

Use for clutch/brake applications. Features dual C-faces and shafts. Input from parallel drive or coupling. Output to reducer. Basic components are field, rotor, 2 armatures and power-on magnet. See page A-28 in this catalog.

Ceramic Faced Input Clutch/Brake

See page A-38



2030-B

Input Clutch/Brake – with Accessory Base Mounting

Base mounting allows the clutch/brake units to be utilized as a separate drive unit. Attach with pulleys, sprockets, etc. See page A-28 in this catalog.

Ceramic Faced Input Clutch/Brake – with Accessory Base Mounting

See page A-38

UM Series UniModule

Selection

UniModule clutch, brake and clutch/brake units may be mounted directly to NEMA C-face motors and reducers, or can be base mounted.

1. Select Configuration

a. NEMA C-face Mounting

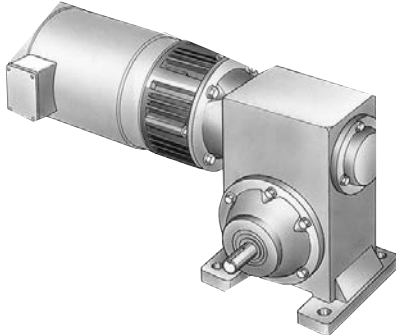

To select the correct UniModule package, determine the NEMA frame size of your motor and/or reducer, and choose the corresponding size UniModule from the Frame Size Selection chart.

Size UM-100 modules utilize a 5/8" diameter shaft to fit 56C/48Y motor frames with components of UM-180 units for higher torque and heat dissipation capacity than the UM-50.

UM-100 modules are available in 1020 and 2030 clutch/brake and 1040 and 3040 clutch configurations. For C-face mounting, select either a 1020 clutch/brake or a 1040 clutch configuration. The 2030 and 3040 configurations are for base mounting.

Frame Size Selection

NEMA Frame Size	UniModule Size
56C/48Y	UM-50* UM-100**
182C/143TC 184C/145TC	UM-180
213C/182TC 215C/184TC	UM-210
213TC/215TC	UM-215

* For 56C/48Y Frame motors 3/4 HP and smaller the UM-100 size may be used where extended life is desirable.

** UM-100 size is recommended for motors 1 HP and larger.

b. Base Mounting

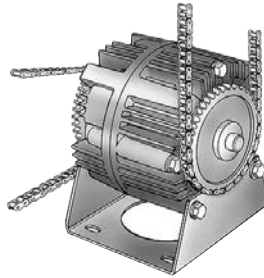

UniModule assemblies may be mounted as separate drive units driven from the prime mover by V-belts, chain and sprockets, couplings, timing belts and other standard power transmission components.

Select the correct size module from the Horsepower vs. Shaft Speed chart by determining the motor horsepower and RPM at the module location. The correct size UniModule is shown at the intersection of the HP and operating speed.

For additional sizing information, refer to the technical sizing procedure (step 2).

2. Determine Technical Requirements

Technical considerations for sizing and selection are torque and heat dissipation. Each merits careful consideration, especially heat dissipation as over time, use in excessive temperature environments will have an adverse effect on bearing life and coil wire insulation integrity.

Compare the calculated torque requirement with the average dynamic torque ratings. Select a unit with adequate torque. If the unit selected on torque is different than the unit selected based on heat, select the larger size unit.

Horsepower vs. Shaft Speed

HP	SHAFT SPEED AT CLUTCH (IN RPM)																		
	100	200	300	400	500	600	700	800	900	1000	1100	1200	1500	1800	2000	2400	3000	3600	
1/4																			
1/2																			
3/4																			
1																			
1-1/2																			
2																			
3																			
5																			
7-1/2																			

*For applications with speeds below 100RPM, please contact Warner Electric Application Support.

a. Heat Dissipation Sizing

Friction surfaces slip during the initial period of engagement and, as a result, heat is generated. The clutch/brake selected must have a heat dissipation rating greater than the heat generated by the application. Therefore, in high inertia or high cycle rate applications, it is necessary to check the heat dissipation carefully. Inertia, speed and cycle rate are the required parameters.

Heat dissipation requirement is calculated as follows:

$$E = 1.7 \times WR^2 \times (N/100)^2 \times F$$

where:

$$E = \text{Heat (lb. ft./min.)}$$

WR^2 = Total reflected inertia at the clutch/brake shaft. Include the clutch/brake output inertia. (lb.ft.²)

N = Speed in revolutions per minute. (RPM)

F = Cycle rate in cycles per minute (CPM)

Compare the calculated heat generated in the application to the unit ratings using the heat dissipation curves. Select the appropriate unit that has adequate heat dissipation ability.

Heat Dissipation Curves

UM 50

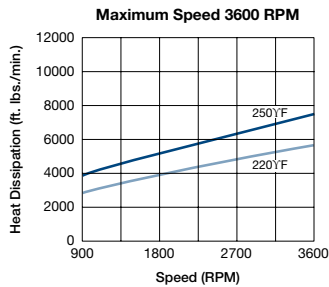

UM 100/180

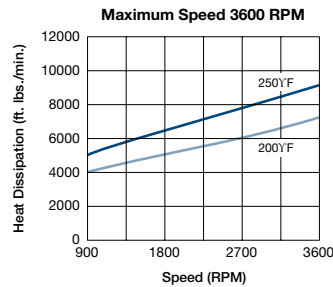

UM 210/215

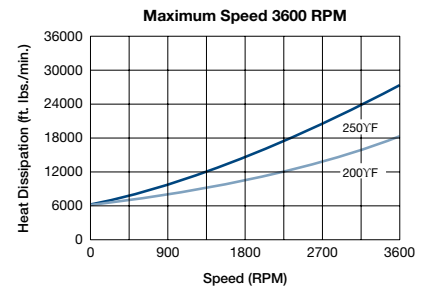

b. Torque Sizing

For most applications, the correct size clutch/brake can be selected from the Horsepower vs. Shaft Speed chart on page 16. Determine the motor horsepower and the RPM at the clutch/brake. The correct size unit is shown at the intersection of horsepower and shaft speed.

If the static torque requirements are known, refer to the technical ratings chart to select a unit.

For some applications, the torque requirement is determined by the time allowed to accelerate and decelerate the load. (This time is generally specified in milliseconds.) For these applications, it is necessary to determine the torque requirement based on load inertia and the time allowed for engagement.

The torque requirements are calculated as follows:

$$T = (WR^2 \times N) / (308 \times t)$$

where:

$$T = \text{Average Dynamic Torque (lb. ft.)}$$

WR^2 = Total reflected inertia at the clutch/brake shaft. Include the clutch/brake output inertia. (lb. ft.²)

N = Speed in revolutions per minute. (RPM)

t = Time allowed for the engagement (sec)

C-face Clutch/Power-on Brake Dynamic Torque Curves

UM 50

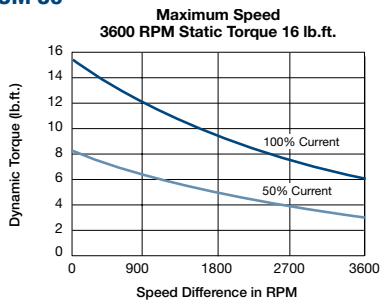

UM 100/180

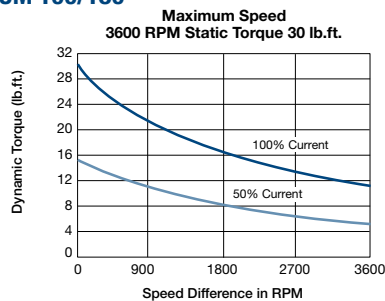

UM 210/215

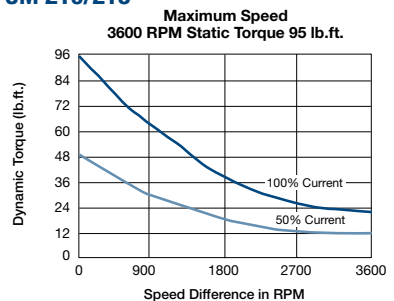

UM Series UniModule

Specifications

UM Size	Static Torque lb. ft.	Maximum RPM	Voltage DC
50	16	3600	6, 24, or 90
100	30	3600	6, 24, or 90
180	30	3600	6, 24, or 90
210	95	3600	6, 24, or 90
215	95	3600	6, 24, or 90

3. Accessories

Warner Electric UniModules can be fitted with several accessories to extend their capacity and ease of mounting.

a. Conduit Box

NEMA 4 and UL listed, available in standard and washdown versions.

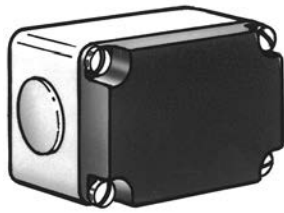

b. Mounting Brackets

Two styles of mounting brackets are available for simplified installation. The base mount is used with the 2030 and 3040 configurations. A motor mount is also available and provides sturdy support for 1020 and 1040 units and a motor.

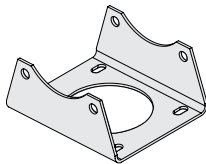

Base Mount

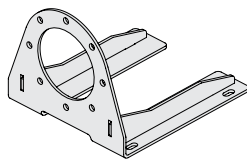

Motor Mount

For 50, 100 & 180 sizes

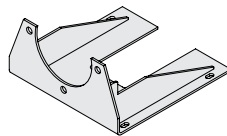

Motor Mount

For 210 & 215 sizes

c. Cover Kit – For sizes 50, 100 & 180



Each cover kit includes two (2) vent covers, two (2) gaskets and four (4) screws needed to convert a vented design into an enclosed design (non-washdown).

4. Select Control

Warner Electric manufactures clutch/brake controls to meet several system functions including:

- On/Off
- Torque adjust
- Over excitation
- Position loop

Many requirements beyond function can impact control selection. See the Controls Section on page 201 for complete information.

Ordering Information

Part Numbers

Model No.	Voltage D.C.	Part No.
1020 Motor Clutch/Brake		
UM-50-1020	6	5370-273-201
UM-50-1020	24	5370-273-203
UM-50-1020	90	5370-273-204
UM-100-1020	6	5370-273-206
UM-100-1020	24	5370-273-208
UM-100-1020	90	5370-273-209
UM-180-1020	6	5370-273-211
UM-180-1020	24	5370-273-213
UM-180-1020	90	5370-273-214
UM-210-1020	6	5371-273-002
UM-210-1020	24	5371-273-004
UM-210-1020	90	5371-273-003
UM-215-1020	6	5371-273-076
UM-215-1020	24	5371-273-077
UM-215-1020	90	5371-273-078
Heavy-Duty Motor Clutch/Brake		
UM-180-1020HD	90	5370-273-323
UM-1020 w/Pre-installed control		
UM50-1020	w/CBC-150-1	90 5370-273-230
UM100-1020	w/CBC-150-1	90 5370-273-231
UM180-1020	w/CBC-150-1	90 5370-273-232
UM180-1020HD	w/CBC-150-1	90 5370-273-324
UM210-1020	w/CBC-150-1	90 5371-4
UM215-1020	w/CBC-150-1	90 5371-273-090
1040 Motor Clutch Output Clutch		
UM-50-1040	6	5370-271-201
UM-50-1040	24	5370-271-203
UM-50-1040	90	5370-271-204
UM-100-1040	6	5370-271-206
UM-100-1040	24	5370-271-208
UM-100-1040	90	5370-271-209
UM-180-1040	6	5370-271-211
UM-180-1040	24	5370-271-213
UM-180-1040	90	5370-271-214
UM-210-1040	6	5371-271-002
UM-210-1040	24	5371-271-004
UM-210-1040	90	5371-271-003
UM-215-1040	6	5371-271-026
UM-215-1040	24	5371-271-027
UM-215-1040	90	5371-271-028
2030 Input Clutch/Brake		
UM-50-2030	6	5370-273-216
UM-50-2030	24	5370-273-218
UM-50-2030	90	5370-273-219
UM-100-2030	6	5370-273-221
UM-100-2030	24	5370-273-223
UM-100-2030	90	5370-273-224
UM-180-2030	6	5370-273-226
UM-180-2030	24	5370-273-228
UM-180-2030	90	5370-273-229
UM-210-2030	6	5371-273-007
UM-210-2030	24	5371-273-009
UM-210-2030	90	5371-273-008
UM-215-2030	6	5371-273-043
UM-215-2030	24	5371-273-044
UM-215-2030	90	5371-273-045

Model No.	Voltage D.C.	Part No.
3040 Input Clutch Output Clutch		
UM-50-3040	6	5370-271-216
UM-50-3040	24	5370-271-218
UM-50-3040	90	5370-271-219
UM-100-3040	6	5370-271-221
UM-100-3040	24	5370-271-223
UM-100-3040	90	5370-271-224
UM-180-3040	6	5370-271-226
UM-180-3040	24	5370-271-228
UM-180-3040	90	5370-271-229
UM-210-3040	6	5371-271-007
UM-210-3040	24	5371-271-009
UM-210-3040	90	5371-271-008
UM-215-3040	6	5371-271-021
UM-215-3040	24	5371-271-022
UM-215-3040	90	5371-271-023

Accessories

Description	UM Size	Part No.
Conduit Box	All sizes	5370-101-042
Base Mount Kit	50/100	5370-101-004
for 2030, 3040	180	5370-101-002
	210/215	5371-101-001
Motor Mount Kit	50/100	5370-101-078
for 1020, 1040	180	5370-101-079
	210/215	5371-101-012
Cover Kit	50/100/180	5370-101-076

How to Order

Motor or Reducer Mounted

Simply combine the size number with the configuration of the required UniModule. Specify voltage. See chart for specific part numbers. Permanent Magnet electrically released brakes in P-8590-WE. Order optional conduit box if desired.

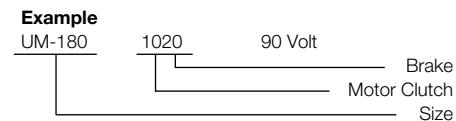

Base Mounted

Simply combine the size number with the configuration of the required UniModule. Specify voltage. See chart for specific part numbers. Permanent Magnet electrically released brakes in P-8590-WE. Order optional conduit box if desired.

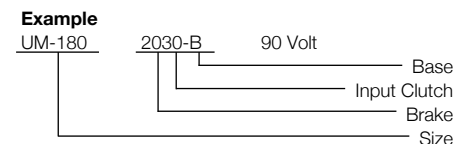

Select Appropriate Power Supply/Control.

UM Series UniModule

UM-1020 Motor Clutch/Brake Combination

SIZE 50/100/180

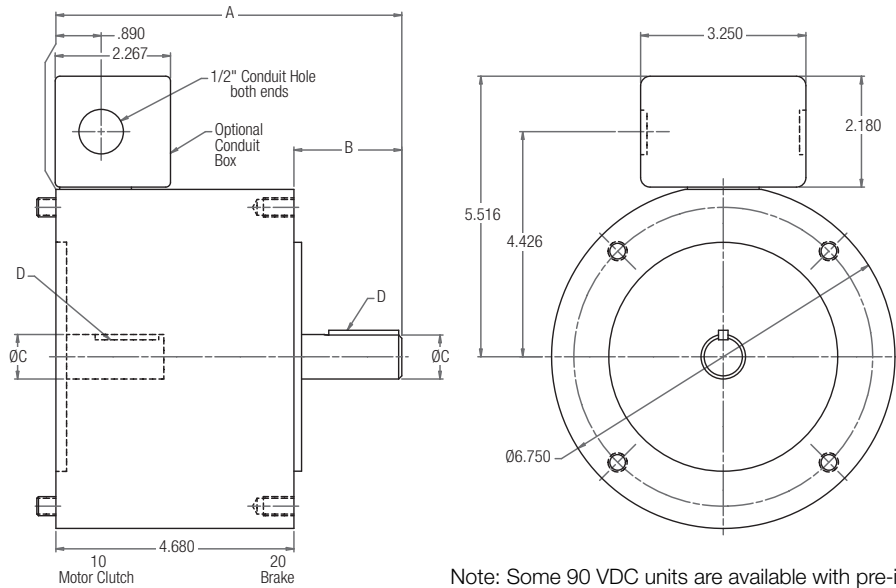

Note: Some 90 VDC units are available with pre-installed controls. On all other modules, conduit box is optional and is ordered separately.

SIZE 210/215

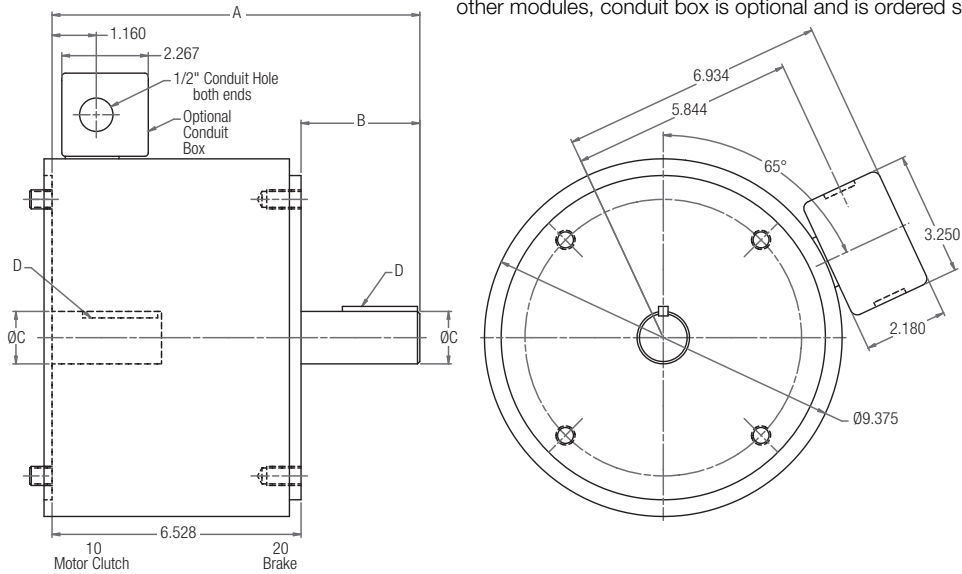

Dimensions

Size	A	B	C	D
50	6.720	2.040	0.625	3/16 x 3/16
100	6.741	2.061	0.625	3/16 x 3/16
180	6.801	2.121	0.875	3/16 x 3/16
210	9.142	2.614	1.125	1/4 x 1/4
215	9.642	3.114	1.375	5/16 x 5/16

Specifications

Model Size	Voltage DC	Static Torque lb. ft.	Max. RPM	NEMA Frame Size
50	6, 24, 90	16	3600	56C/48Y*
100	6, 24, 90	30	3600	56C/48Y**
180	6, 24, 90	30	3600	182C/143TC 184C/145TC
210	6, 24, 90	95	3600	213C/182TC 215C/184TC
215	6, 24, 90	95	3600	213TC/215TC

* For 56C/48Y Frame motors 3/4 HP and smaller the UM-100 size may be used where extended life is desirable.

** UM-100 size is recommended for motors 1 HP and larger.
For standard NEMA frame dimensions, see page G-3.

UM-1040 Motor Clutch/Output Clutch Combination

SIZE 50/100/180

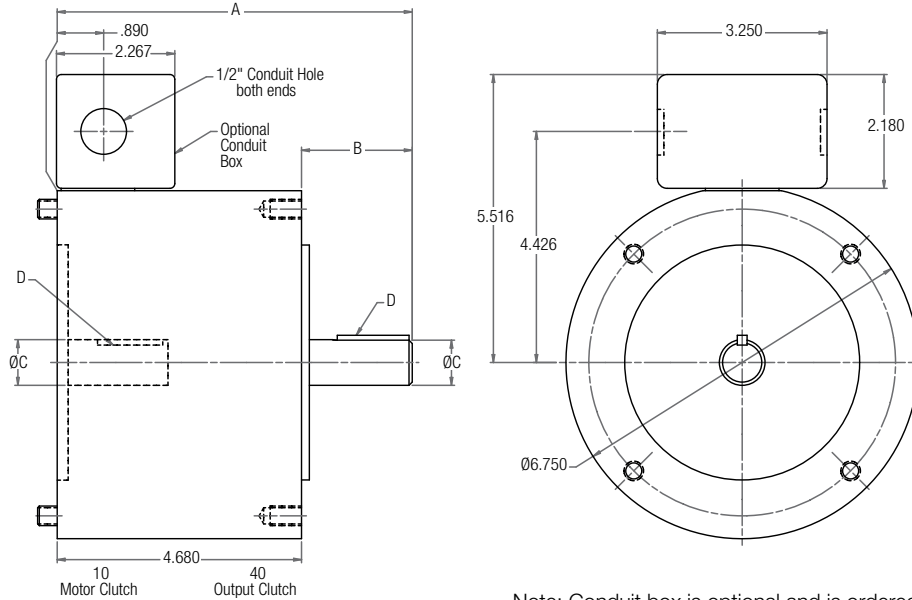

Note: Conduit box is optional and is ordered separately.

SIZE 210/215

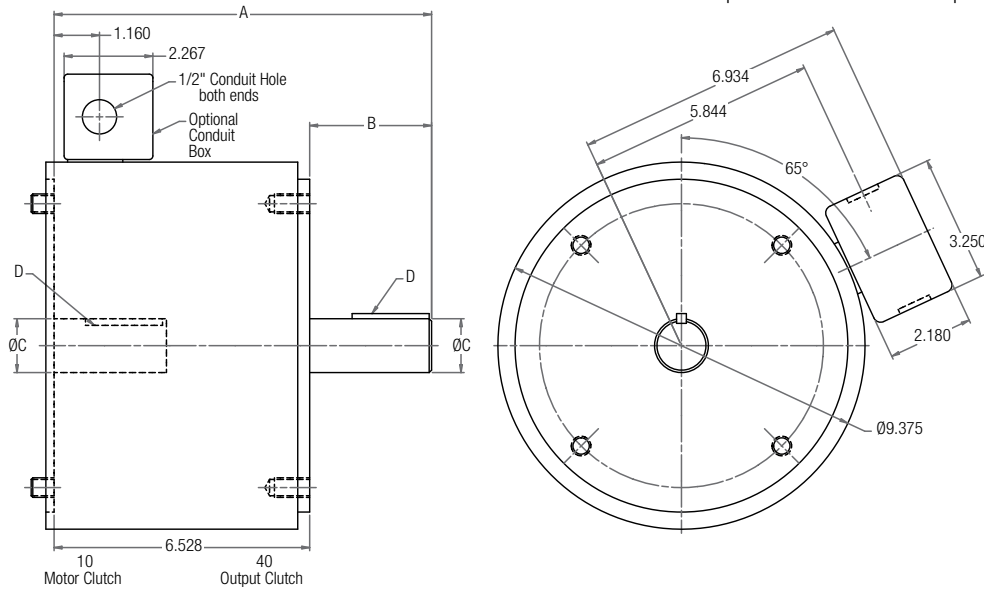

Dimensions

Size	A	B	C	D
50	6.720	2.040	0.625	3/16 x 3/16
100	6.741	2.061	0.625	3/16 x 3/16
180	6.801	2.121	0.875	3/16 x 3/16
210	9.142	2.614	1.125	1/4 x 1/4
215	9.642	3.114	1.375	5/16 x 5/16

Specifications

Model Size	Voltage DC	Static Torque lb. ft.	Max. RPM	NEMA Frame Size
50	6, 24, 90	16	3600	56C/48Y*
100	6, 24, 90	30	3600	56C/48Y**
180	6, 24, 90	30	3600	182C/143TC 184C/145TC
210	6, 24, 90	95	3600	213C/182TC 215C/184TC
215	6, 24, 90	95	3600	213TC/215TC

* For 56C/48Y Frame motors 3/4 HP and smaller the UM-100 size may be used where extended life is desirable.

** UM-100 size is recommended for motors 1 HP and larger.

For standard NEMA frame dimensions, see page G-3.

UM Series UniModule

UM-2030 Input Clutch/Brake Combination UM-2030-B Input Clutch/Brake Combination – Base Mounted

SIZE 50/100/180

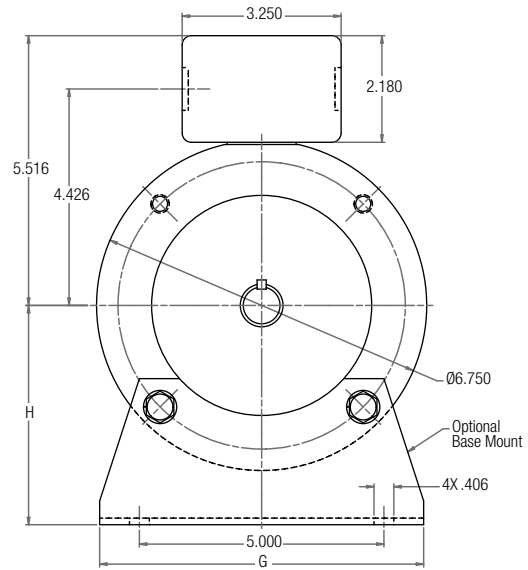
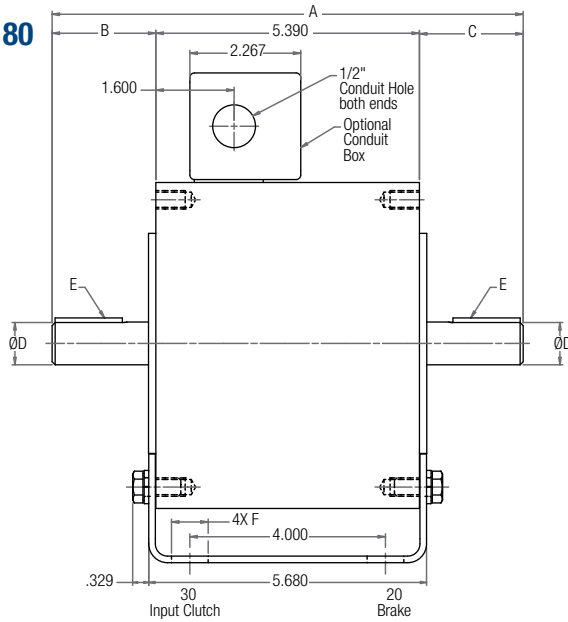

Note: Mounting base and conduit box are optional and are ordered separately.

SIZE 210/215

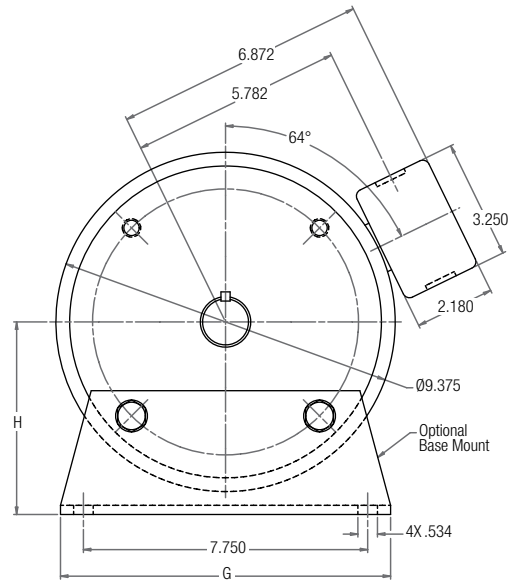
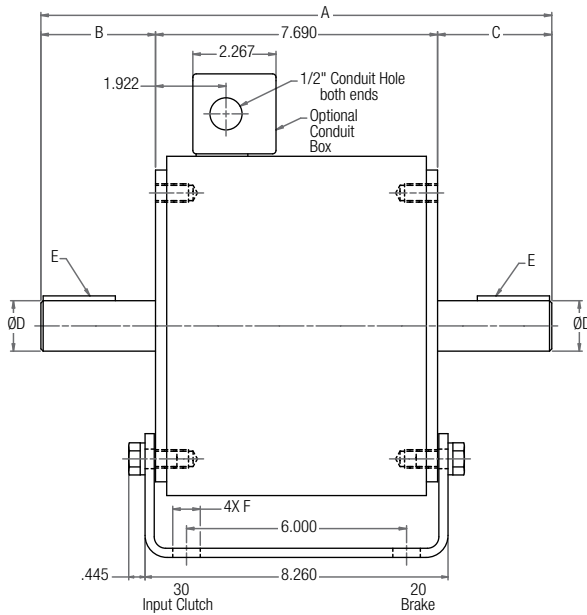

Dimensions

Size	A	B	C	D	E	F	G	H
50	9.492	2.062	2.040	0.625	3/16 x 3/16	0.800	6.000	3.500
100	9.512	2.061	2.061	0.625	3/16 x 3/16	0.800	6.000	3.500
180	9.632	2.121	2.121	0.875	3/16 x 3/16	0.750	6.625	4.500
210	12.929	2.625	2.614	1.125	1/4 x 1/4	0.750	9.000	5.250
215	13.929	3.125	3.114	1.375	5/16 x 5/16	0.750	9.000	5.250

Specifications

Model Size	Voltage DC	Static Torque lb. ft.	Max. RPM
50	6, 24, 90	16	3600
100	6, 24, 90	30	3600
180	6, 24, 90	30	3600
210	6, 24, 90	95	3600
215	6, 24, 90	95	3600

For standard NEMA frame dimensions, see page G-3.

UM-3040 Input Clutch/Output Clutch Combination UM-3040-B Input Clutch/Output Clutch Combination—Base Mounted

SIZE 50/100/180

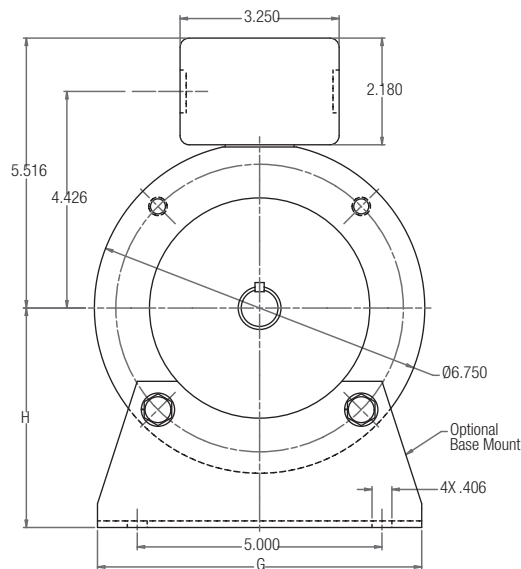
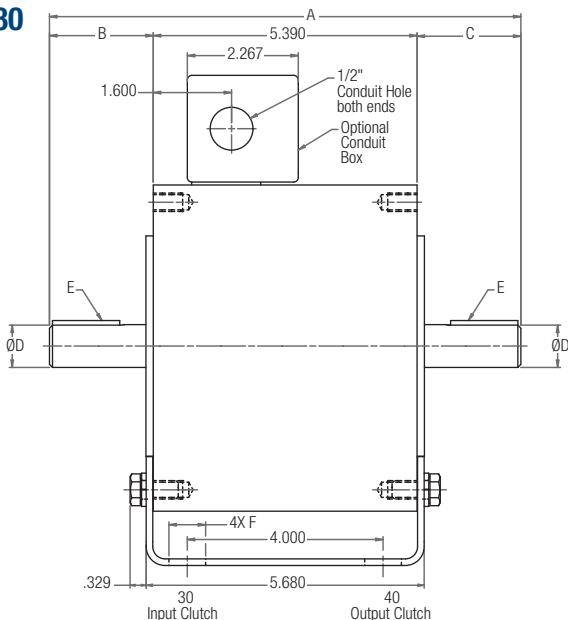

Note: Mounting base and conduit box are optional and are ordered separately.

SIZE 210/215

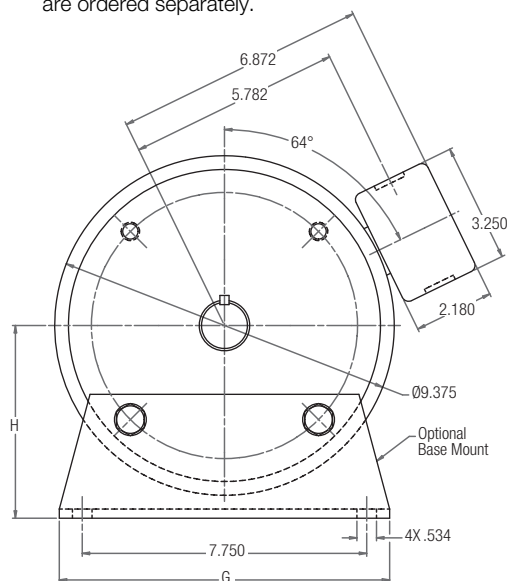
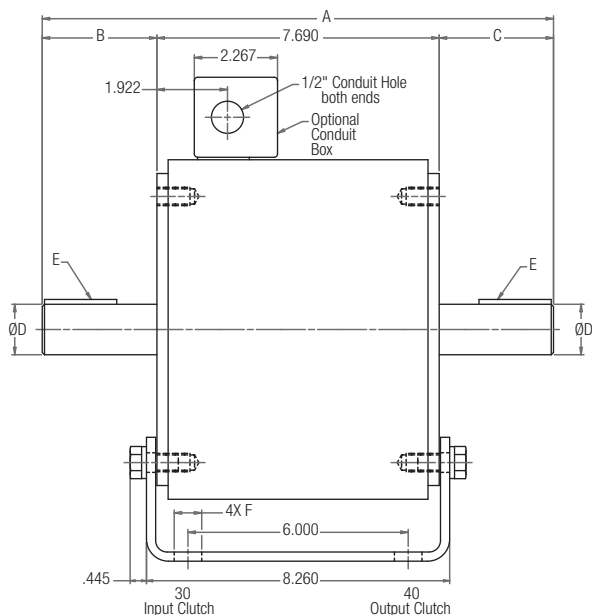

Dimensions

Size	A	B	C	D	E	F	G	H
50	9.492	2.062	2.040	0.625	3/16 x 3/16	0.800	6.000	3.500
100	9.512	2.061	2.061	0.625	3/16 x 3/16	0.800	6.000	3.500
180	9.632	2.121	2.121	0.875	3/16 x 3/16	0.750	6.625	4.500
210	12.929	2.625	2.614	1.125	1/4 x 1/4	0.750	9.000	5.250
215	13.929	3.125	3.114	1.375	5/16 x 5/16	0.750	9.000	5.250

Specifications

Model Size	Voltage DC	Static Torque lb. ft.	Max. RPM
50	6, 24, 90	16	3600
100	6, 24, 90	30	3600
180	6, 24, 90	30	3600
210	6, 24, 90	95	3600
215	6, 24, 90	95	3600

For standard NEMA frame dimensions, see page G-3.