

Warner Electric's electronic controls are designed to provide simple setup and maximum performance when used with electric clutches and brakes. Our controls offer a range of functions from on-off to torque control to over-excitation.

### Selection

Many parameters beyond function can impact control selection. Warner Electric produces a variety of control options to suit numerous application requirements. Control selection parameters include:

- Mounting Location – Panel or conduit box mounting
- Switching – Relay switching of A.C. or D.C. lines or solid state switching
- Output Voltage – Controls are available for 6, 24 and 90 VDC clutch/brake coils
- Input Voltage – Controls with input power transformers are available for connection to high voltage mains.

If your application requires something special, please call us. We will be happy to provide solutions.

|  |     |
|--|-----|
| <b>Clutch and Brake Controls</b> ..... | 262 |
|--|-----|

### On-Off Controls

|               |     |
|---------------|-----|
| CBC-100 ..... | 264 |
| CBC-150 ..... | 264 |
| CBC-160 ..... | 265 |
| CBC-801 ..... | 266 |
| CBC-802 ..... | 267 |
| CBC-400 ..... | 268 |
| CBC-450 ..... | 269 |

### Adjustable Torque Controls

|  |     |
|--|-----|
| MCS-103-1 .....  | 270 |
| MCS-153 .....  | 271 |
| CBC-200 ( <i>Obsolete, replaced by CBC-300</i> ) ..... | 272 |
| CBC-300 .....  | 272 |
| CBC-500 .....  | 273 |
| CBC-550 .....  | 274 |
| CBC-1825R .....  | 276 |

### Overexcitation Controls

|               |     |
|---------------|-----|
| CBC-700 ..... | 277 |
| CBC-750 ..... | 278 |

### Closed Loop Position Control

|                |     |
|----------------|-----|
| CBC-1000 ..... | 280 |
|----------------|-----|

|                       |     |
|-----------------------|-----|
| <b>Appendix</b> ..... | 282 |
|-----------------------|-----|

|                                      |     |
|--------------------------------------|-----|
| <b>Questions &amp; Answers</b> ..... | 283 |
|--------------------------------------|-----|



# Clutch and Brake Controls

## Functions

### On-Off (Basic start-stop)

Many applications are controlled by energizing the clutches and brakes with their rated D.C. voltages. Warner Electric controls are available with various mounting, input voltage and switching options.

### Adjustable Torque

#### (Soft start-stop)

The torque transmitted by a clutch or brake is proportional to the coil current. Warner Electric offers several products that provide torque control for smooth and repeatable starts and stops.

### Adjustable Accel-Decel

#### (Soft start-stop with full torque)

Warner Electric offers a control that allows for adjustment of the acceleration and deceleration time ramps to achieve a repeatable soft start or stop while still allowing for full torque.

### Overexcitation

#### (Rapid cycling)

The clutch/brake speed of response can be increased for improved accuracy and performance through overexcitation, which is the application of a short high voltage pulse to provide nearly instantaneous torque.

### Position Loop

#### (Programmable cycling)

Warner Electric's CBC-1000 position loop control system offers servo system performance with electric clutch/brake economy in high accuracy indexing applications. The unique error correction capability of the CBC-1000 to achieve repeatability and accuracy makes this an ideal control for many applications.

#### Control Type

##### On-Off Conduit Box Mount



##### On-Off Octal Socket Mount



##### On-Off Panel Mount

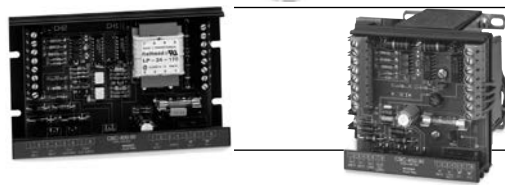

##### Adjustable Torque



##### Adjustable Accel-Decel

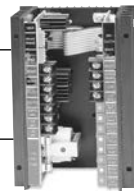

##### Overexcitation



##### Position Loop



# Clutch and Brake Controls

| Model Number                         | No. of Channels | Torque Control Channels | A.C. Input Voltages | D.C. Output Voltages | Over-Excitation | Customer Supplied Switching Options  | Description   | Page Number |
|--------------------------------------|-----------------|-------------------------|---------------------|----------------------|-----------------|--------------------------------------|---|-------------|
| CBC-100-1                            | 1               | No                      | 120                 | 90                   | No              | Relay A.C.                           | Single channel control to mount inside standard conduit box   | 264         |
| CBC-100-2                            | 1               | No                      | 220/240             |                      |                 |                                      |   |             |
| CBC-150-1                            | 2               | No                      | 120                 | 90                   | No              | Relay A.C.                           | Dual channel control for clutch/brake to mount inside module conduit box  | 264         |
| CBC-150-2                            | 2               | No                      | 220/240             |                      |                 |                                      |   |             |
| CBC-160-1                            | 1               | 1                       | 120                 | 90                   | No              | Relay A.C.                           | Single channel control with torque adjust for module electrically released brakes   | 265         |
| CBC-160-2                            |                 |                         | 220/240             |                      |                 |                                      |   |             |
| CBC-801-1                            | 2               | No                      | 120                 | 90                   | No              | Relay D.C.                           | Dual channel control for 2 clutches and/or brakes   | 266         |
| CBC-801-2                            | 2               |                         | 220/240             |                      |                 |                                      |   |             |
| CBC-802                              | 2               | No                      | 120                 | 90                   | No              | Transistor or Relay D.C.             | Dual channel control with transistor switching  | 267         |
| CBC-400-90                           | 2               | No                      | 120                 | 90                   | No              | Transistor or Relay D.C.             | Dual channel control for use with 2 clutches and/or brakes; Emergency stop input and AUX power supply                       | 268         |
| CBC-400-24                           | 2               | No                      | 24-30               | 24                   | No              |                                      |   |             |
| CBC-450-90                           | 2               | No                      | 120/220/240/380/480 | 90                   | No              |                                      |   |             |
| CBC-450-24                           | 2               | No                      | 120/220/240/380/480 | 24                   | No              |                                      |   |             |
| MCS-103-1                            | 2               | 1                       | 120                 | 90                   | No              | Relay D.C.                           | Dual channel control with torque adjust for one channel   | 270         |
| MCS-805-1                            | 1               | 1                       | 120/240             | 35-75                | No              | Relay D.C.                           | Single adjustable channel control for use with ER 1225 brake  | 271         |
| MCS-805-2                            |                 |                         |                     |                      |                 |                                      |   |             |
| CBC-200                              | 2               | 1                       | 120                 | 90                   | No              | Transistor or Relay D.C.             | Dual channel control with one adjustable current and one fixed voltage  | 272         |
| <b>Obsolete, replaced by CBC-300</b> |                 |                         |                     |                      |                 |                                      |   |             |
| CBC-300                              | 2               | 2                       | 120                 | 90                   | No              | Transistor or Relay D.C.             | Dual channel adjustable current control   | 272         |
| CBC-500-90                           | 2               | 2                       | 120                 | 90                   | No              | Transistor or Relay D.C.             | Dual channel control for two clutches and/or brakes with two torque adjust channels; Emergency stop input                   | 273         |
| CBC-500-24                           | 2               | 2                       | 24-30               | 24                   | No              |                                      |   |             |
| CBC-550-90                           | 2               | 2                       | 120/220/240/380/480 | 90                   | No              |                                      |   |             |
| CBC-550-24                           | 2               | 2                       | 120/220/240/380/480 | 24                   | No              |                                      |   |             |
| CBC-1825-R                           | 2               | 2                       | 120                 | 90                   | No              | Transistor or Relay D.C.             | Dual channel adjustable time ramp with short circuit protection   | 276         |
| CBC-700-90                           | 2               | No                      | 120                 | 90                   | Yes             | Transistor or Relay D.C.             | Dual channel compact overexcitation control for 24 or 90 volt clutches and brakes   | 277         |
| CBC-700-24                           | 2               |                         | 24-28               | 24                   |                 |                                      |   |             |
| CBC-750-6-24-90                      | 2               | 2                       | 120/220/240         | 6,24,90              | Yes             | Transistor, Relay D.C. or Triac A.C. | Dual channel full function overexcitation control; provides input/output logic, torque adjustable current and remote inputs | 278         |
| CBC-1000                             | 2               | N.A.                    | 120/230             | N.A.                 | N.A.            | N.A.                                 | Error correction control to be used with one of the above   | 280         |

# On-Off Controls **CBC-100, CBC-150**

## Integral/Conduit Box Mounted Controls

The CBC-100 and CBC-150 series are UL listed, conduit box mounted controls for 90 volt clutches and brakes. Models are available for either 120 VAC or 220/240 VAC input.



### CBC-100 series Single unit capacity

The CBC-100 mounts inside a standard Warner Electric conduit box and includes rectification and suppression circuits.

- and and
- 
- Compact
- Single channel
- Mounts inside conduit box



### CBC-150 series Dual channel capacity

The CBC-150 replaces the cover on the standard module conduit box (part no. 5370-101-042). Provides rectification and suppression for two devices. Green LED indicates power to clutch. Red LED indicates power to brake.

- and
- Dual channel
- Replaces the cover on the module conduit box

## Specifications

|  | CBC-100-1  | CBC-100-2                  | CBC-150-1                                    | CBC-150-2                       |
|--|--|----------------------------|--|---------------------------------|
| Part No.   | 6003-448-101   | 6003-448-103               | 6004-448-001                                 | 6004-448-002                    |
| Input  | 120 VAC<br>50/60 Hz  | 220/240 VAC<br>50/60 Hz    | 120 VAC<br>50/60 Hz                          | 220/240 VAC<br>50/60 Hz         |
| Output   | 90 VDC full wave<br>rectified<br>.8 Amp max.                         | 90 VDC half wave<br>.8 Amp | 90 VDC full wave<br>rectified<br>Dual .8 Amp | 90 VDC half wave<br>Dual .8 Amp |
| Ambient<br>Temperatures                              | -20° to 113°F (-29° to 45°C)   |                            |  |                                 |
| Switching  | External to control, accomplished on A.C. line using relay or triac. |                            |  |                                 |
|  | SPST   | SPST                       | SPDT   | SPDT                            |
| Solid State<br>(maximum<br>leakage<br>current <2 mA) | 140 VAC,<br>1 Amp min.   | 280 VAC,<br>1 Amp min.     | 140 VAC,<br>2 Amp min.                       | 280 VAC,<br>2 Amp min.          |
| Electro-<br>mechanical                               | 120 VAC,<br>1 Amp min.   | 240 VAC,<br>1 Amp min.     | 120 VAC,<br>1 Amp min.                       | 240 VAC,<br>1 Amp min.          |

## Connection diagrams

### CBC-100-1, -2

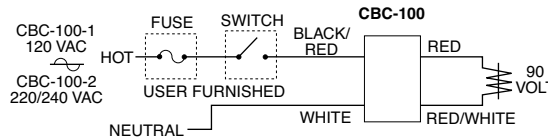

## Dimensions

### CBC-100-1, -2

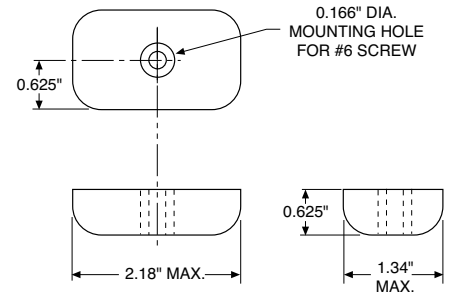

### CBC-150-1, -2

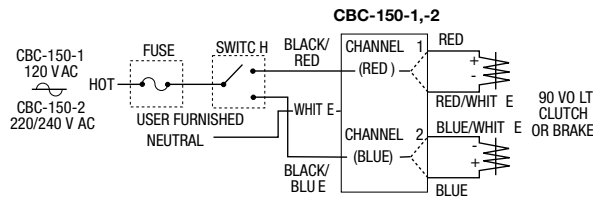

### CBC-150-1, -2

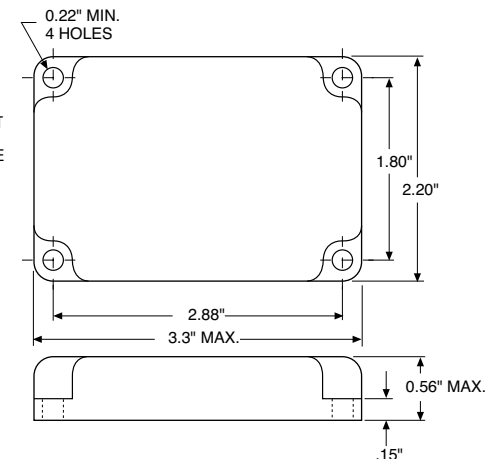

All dimensions nominal unless otherwise specified.

## Integral/Electrically Released Motor Brake Controls

### CBC-160

The CBC-160 series clutch/brake controls provide a single 90 VDC adjustable output for use with any clutch/brake unit. The adjustable output will provide consistent and repeatable release for Warner Electric's 90 VDC permanent magnet electrically released brakes.



The CBC-160 mounts as the cover on the standard module conduit box (part no. 5370-101-042).

The 160-1 accommodates 120 volts A.C. motors.

- 
- Adjustable 30-100 VDC
- LED indicator
- 120 volt A.C. input

The power to the 160-2 control can come from either a 230 volt or 460 volt A.C. motor. Customer-provided switching is accomplished through the motor starter on the A.C. input. This allows convenient retrofit of spring-set style motor brakes and inexpensive installation of new applications.

- 
- Adjustable 30-100 VDC
- Power from motor
- Easy retrofit
- 230/460 motors

### Dimensions

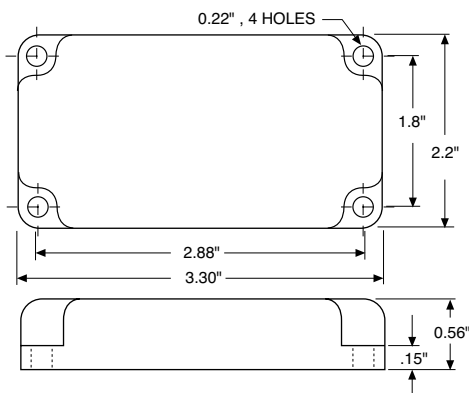

All dimensions nominal unless otherwise specified.

### Specifications

|                      | CBC-160-1  | CBC-160-2                                |
|----------------------|--|--|
| Part No.             | 6013-448-001   | 6013-448-002                             |
| Input                | 120 VAC, 50/60 Hz  | 220/240 VAC, 60 Hz, 1 Phase, 100 VA max. |
| Status Indicator     | Red LED indicates power to the brake                                     | —  |
| Output               | Single Channel, 30-100 VDC half-wave rectified nominal, 0.8 Amps maximum |  |
| Ambient Temperatures | 0° to 122°F (-18° to 50°C)   |  |
| Switching            | Accomplished through motor starter or on A.C. line using relay or triac  |  |

### Connection Diagram

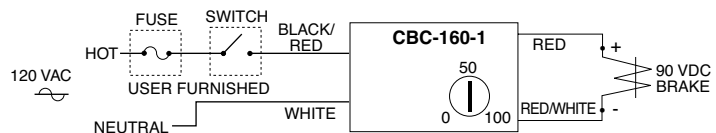

### WYE Connected Motor

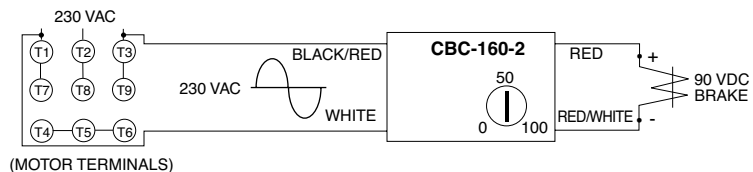
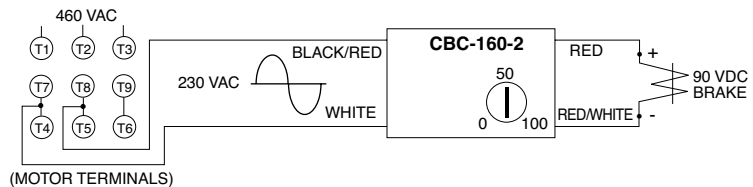

### DELTA Connected Motor

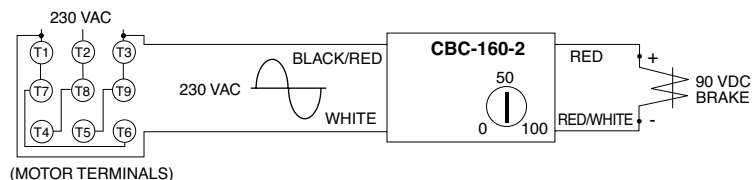
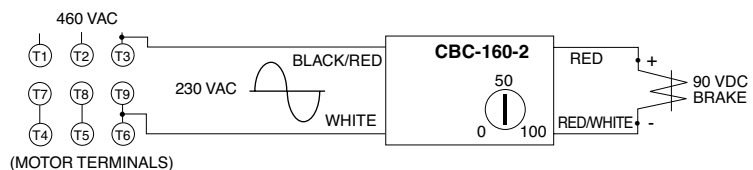



# On-Off Controls **CBC-801**

## Plug-in Octal Socket Power Supplies

The CBC-801 is a basic on-off power supply that provides full voltage to a 90 volt clutch or brake and is activated by an external switch. This type of power supply is sufficient for many clutch/brake applications.

### CBC-801 series Multi-unit capacity

The CBC-801 is a plug-in power supply which is used with an octal socket. The wiring connections are made at the socket. The CBC-801 will operate two units separately—or simultaneously. Octal socket is purchased separately.

-  
- For basic on-off operation
- Wiring connections made at octal socket
- Arc suppression circuitry extends switch life
- Fused for overload protection
- LED output indicators
- DIN rail mountable



### Dimensions

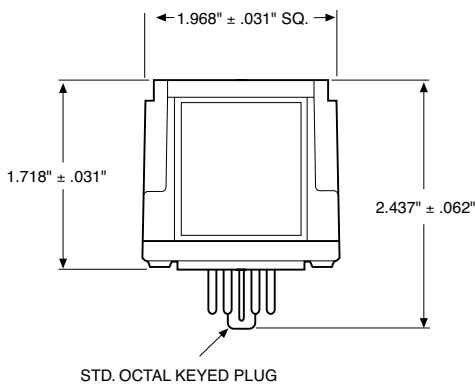

### Specifications

|                     | CBC-801-1  | CBC-801-2             |
|---------------------|--|-----------------------|
| Part No.            | 6001-448-004   | 6001-448-006          |
| Input Voltage       | 120 VAC, 50/60 Hz  | 220/240 VAC, 50/60 Hz |
| Output              | 90 VDC, 1.25 A max.  |                       |
| Circuit Protection  | Fused 1.6 Amp, 250 V fast-blo  |                       |
| Ambient Temperature | -23° to 116°F (-31° to 47°C)   |                       |
| Max. Cycle Rate     | Limited by the clutch or brake, variable with application  |                       |
| Switching           | Single pole, double throw<br>Minimum contact rating: 10 Amp, 28 VDC resistive or 10 Amp, 120 VAC inductive |                       |
| Status Indicator    | Red LED indicates brake is energized, Green LED indicates clutch is energized                              |                       |
| Mounting            | Two versions of octal socket are available:<br>6001-101-001 foot mount<br>6001-101-002 DIN rail mount      |                       |

### OCTAL SOCKET

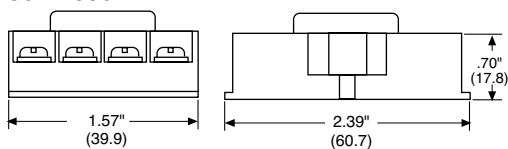

### DIN RAIL MOUNT SOCKET

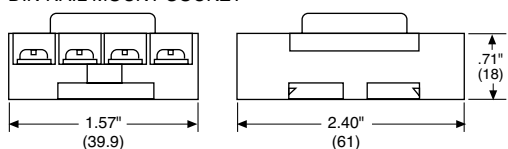

All dimensions nominal unless otherwise specified.

### Connection Diagram

Connection diagram for operating clutch/brake separately.

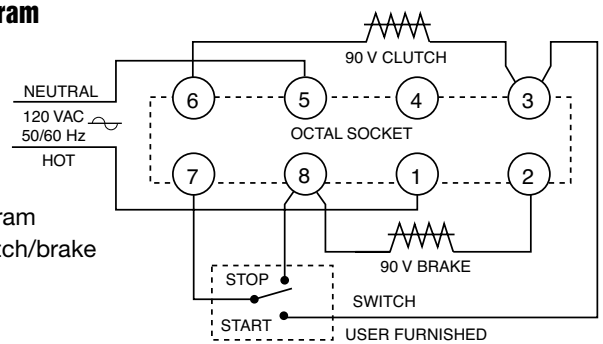

Connection diagram for operating clutch/brake simultaneously.

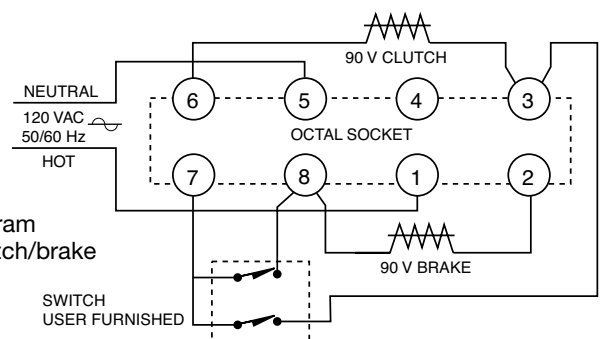

## Plug-in Octal Socket Power Supplies



### CBC-802 PLC compatible

The CBC-802 is a power supply with solid state circuits for load switching. A brake and clutch may be operated separately—or, two brakes or two clutches, one unit on at a time. The CBC-802 mounts on an octal socket (purchased separately), and the wiring connections are made at the socket terminals. Octal socket sold separately, refer to mounting specifications for part number.

-  Plug-in power supply with solid state switching circuits—increases switch service life
- Adjustable time delay for controlling clutch/brake overlap
- Internally fused for overload protection
- DIN rail mountable
- LED output indicators

### Dimensions

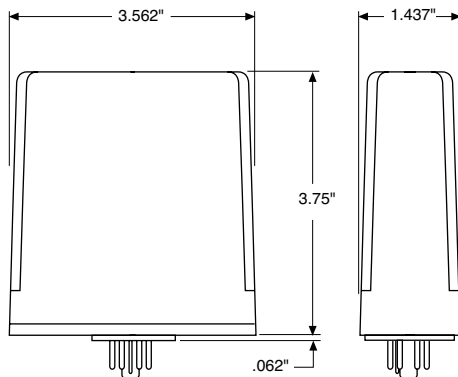

STD. OCTAL KEYPED PLUG

All dimensions nominal unless otherwise specified.

### Specifications

| CBC-802             |   |
|---------------------|---|
| Part No.            | 6002-448-001  |
| Input               | 120 VAC, 50/60 Hz   |
| Output              | 90 VDC, 0.5 A max.  |
| Status Indicator    | Red LED indicates brake energized. Green LED indicates clutch energized.  |
| Circuit Protection  | Fused 0.5 Amps, 250 V   |
| Ambient Temperature | -20° to 113°F (-29° to 45°C)  |
| Leakage Current     | 500 uA max. for solid state switches  |
| Max. Cycle Rate     | Limited by the clutch or brake, variable with application   |
| Switching           | Momentary contact, maintained contact, or solid state open collector logic<br>Minimum contact rating 20 VDC resistive, 0.01 Amps<br>Minimum input pulse—1 millisecond |
| Adjustments         | Externally adjusted potentiometer sets overlap between clutch and brake from 0 to 130 MS.   |
| Mounting:           | Two versions of octal socket are available:<br>6001-101-001 foot mount<br>6001-101-002 DIN rail mount   |

### Connection Diagram

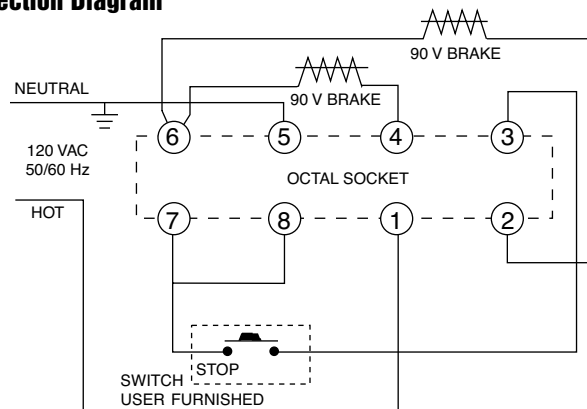

#### OCTAL SOCKET

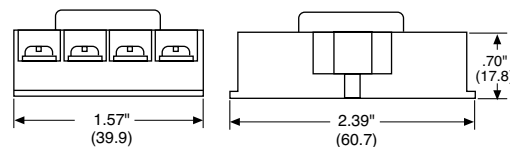

#### DIN RAIL MOUNT SOCKET

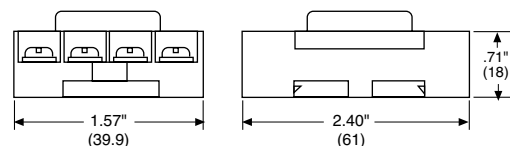

# On-Off Controls **CBC-400**

## Panel Mounted Control



### Specifications

|                     | <b>CBC-400-90</b>   | <b>CBC-400-24</b>              |
|---------------------|---|--------------------------------|
| Part No.            | 6006-448-003  | 6006-448-002                   |
| Input Voltage       | 120 VAC   | 24-30 VAC                      |
| Output Voltage      | 90 VDC  | 24 VDC                         |
| Output Current      | 1 Amp/Channel<br>2 Amps Total   | 5 Amps/Channel<br>5 Amps Total |
| Auxiliary Supply    | 12 VDC 250 mA   |                                |
| Circuit Protection  | Fused 2.5 Amp, 250 V fast-blo   | Fused 6.3 Amp, 250 V fast-blo  |
| Ambient Temperature | +32° to 122°F (0° to 50°C)  |                                |
| Status Indicators   | Red LED indicates channel is energized.   |                                |
| Adjustments         | Jumper for single or dual operation. See appendix on page 282 for explanation.  |                                |
| Inputs              | 3 Optically isolated, 10-30 VDC, 3-9 mA for Channel 1, Channel 2 and Channel 2 override (applies full voltage to channel 1 output). |                                |

### Connection Diagram

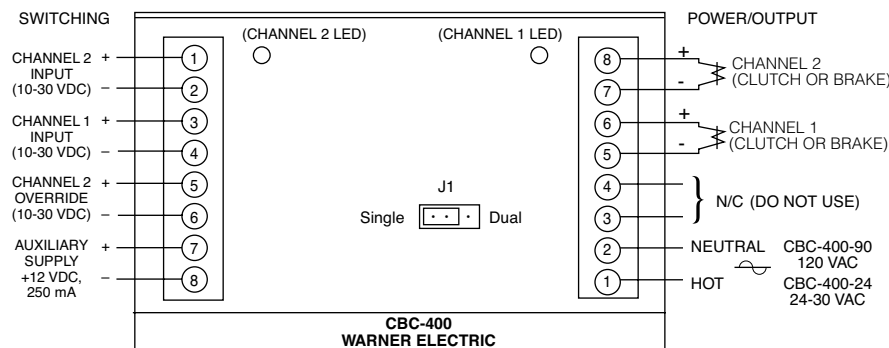

All dimensions nominal unless otherwise specified.

### CBC-400 series Dual channel controls

The CBC-400 series is a basic on-off control which supplies 24 or 90 VDC for electric clutch/brake operation. They offer optically isolated switching inputs for start, stop, and emergency stop (E-stop). These controls can be set up to operate the two outputs alternately (single) or simultaneously (dual). Refer to the Appendix page 282 for additional setup and switching information.

- 24 or 90 Volt DC output
- Auxiliary 12V supply
- Fast coil suppression
- Single or dual channel operation
- Optically isolated input switching

### Enclosure (Optional)



- Lift off hinge
- Quick-release latches
- Conforms to NEMA Type 13
- European Standard IEC 529, IP65

| Part No. | <b>6042-101-004</b>                           |
|----------|---|
| Size     | 8"H x 6"W x 4"D<br>(203.2 x 152.4 x 101.6 mm) |

### Dimensions

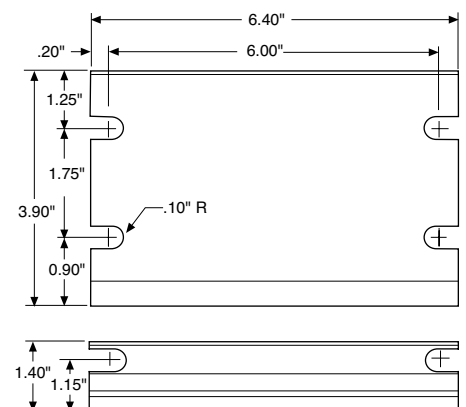



## Panel Mounted Control

### CBC-450 series Dual channel control with transformer for variable input voltage

The CBC-450 series is a basic on-off control which supplies 24 or 90 VDC for electric clutch/brake operation. They offer optically isolated switching inputs for start, stop, and emergency stop (E-stop). These controls can be set up to operate the two outputs, alternately (single) or simultaneously (dual). Refer to the Appendix page 282 for additional setup and switching information. The CBC-450 series has a power transformer which will operate with a 120, 220, 240, 380 or 480 VAC input.



- 24 or 90 Volt DC output
- Auxiliary 12V supply
- Fast coil suppression
- Single or dual channel operation
- Optically isolated switching

### Enclosure (Optional)



- Lift off hinge
- Quick-release latches
- Conforms to NEMA Type 13
- European Standard IEC 529, IP65

|                 |   |
|-----------------|---|
| <b>Part No.</b> | <b>6006-101-007</b>                           |
| <b>Size</b>     | 6"H x 6"W x 6"D<br>(152.4 x 152.4 x 152.4 mm) |

### Specifications

|                     | <b>CBC-450-90</b>   | <b>CBC-450-24</b>              |
|---------------------|---|--------------------------------|
| Part No.            | 6006-448-006  | 6006-448-005                   |
| Input Voltage       | 120/220/240/380/480 VAC   |                                |
| Output Voltage      | 90 VDC  | 24 VDC                         |
| Output Current      | 1 Amp/Channel<br>1.2 Amps Total   | 4 Amps/Channel<br>4 Amps Total |
| Auxiliary Supply    | 12 VDC 250 mA   |                                |
| Circuit Protection  | Fused 1.5 Amp   | Fused 5 Amp                    |
| Ambient Temperature | +32° to 122°F (0° to 50°C)  |                                |
| Status Indicators   | Red LED indicates channel is energized.   |                                |
| Adjustments         | Jumper for single or dual operation. See appendix on page 282 for explanation.                    |                                |
| Inputs              | 3 Optically isolated, 10-30 VDC, 3-9 mA for Channel 1, Channel 2 and Channel 2 override (E-stop). |                                |

### Dimensions

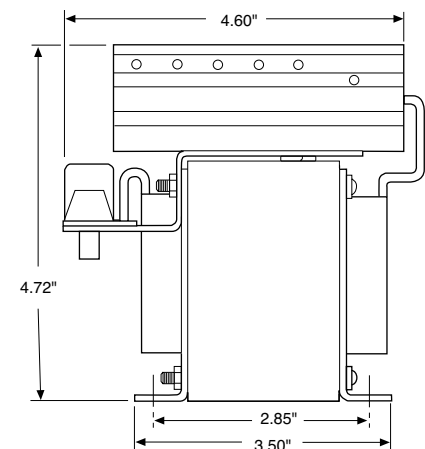
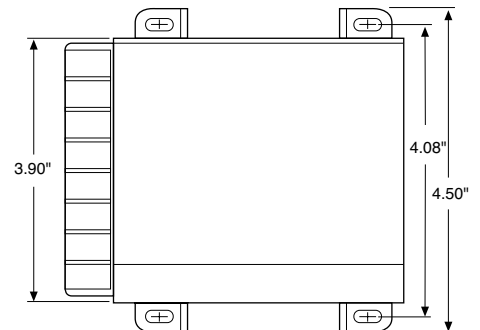

### Connection Diagram

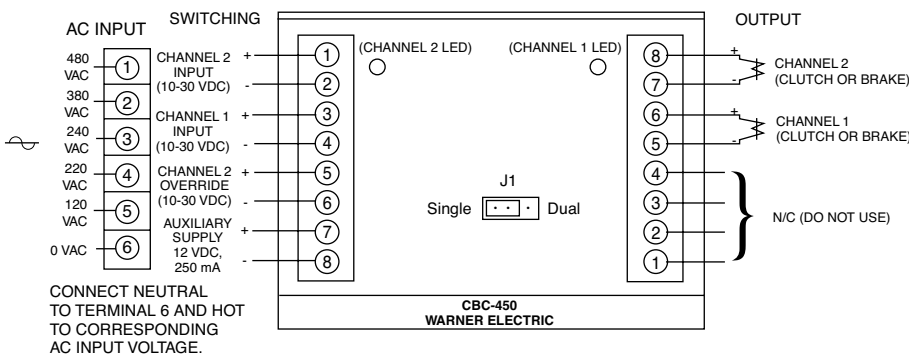

All dimensions nominal unless otherwise specified.

# Adjustable Torque Controls MCS-103-1

## Adjustable Torque Control

The MCS-103-1 is an enclosed control complete with a cover and mounting provisions. A brake and clutch may be operated separately with this control — or up to four units, two at a time. The external wiring is connected to the terminal strip located behind the cover.



- Can be used with electrically released brakes

- Torque control for one 90 VDC clutch or brake
- Operates up to four units, two on at a time
- Easy-to-install. Compact. 120 VAC input
- Convenient terminal strip behind an easy-to-remove cover



## Dimensions

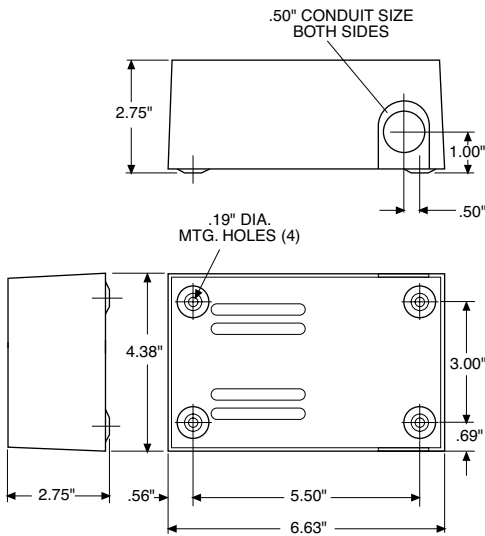

All dimensions nominal unless otherwise specified.

## Specifications

| MCS-103-1                          |  |
|------------------------------------|--|
| Part No.                           | 6010-448-002   |
| Input                              | 120 VAC, 50/60 Hz  |
| Output                             | 1.25 Amp<br>90 V full wave rectified for one unit and adjustable from 0-90 volts full wave rectified for second unit   |
| Circuit Protection                 | Fused 1.5 Amp, 250 V   |
| Ambient Temperature                | -20° to 113°F (-29° to 45°C)   |
| Maximum Cycle Rate                 | Limited by the clutch or brake and will vary with application.   |
| Mounting                           | Mounting centers 5-1/2" wide, 3" high. Knockouts for 1/2" conduit  |
| External Switches (User furnished) | Double pole, double throw maintained contact. Minimum contact rating: 10 Amp, 28 VDC resistive or 10 Amp, 120 VAC inductive.<br>Contact ratings given will operate all Warner Electric brake and clutch units. However, switches with ratings less than those given may be used with fractional horsepower units provided the rating is equal to or greater than the coil current. |

## Connection Diagrams

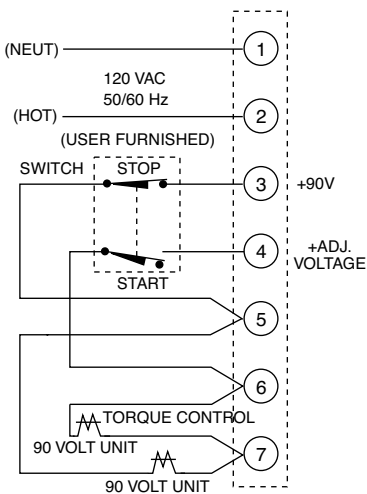

Normal Clutch/Brake Operation  
(One unit on at a time)

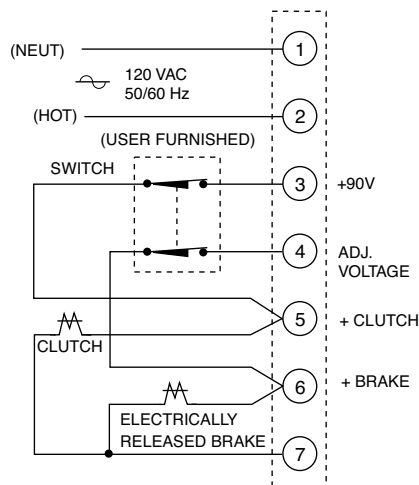

Clutch/Electrically Released  
Brake Operation  
(Both units on at a time)

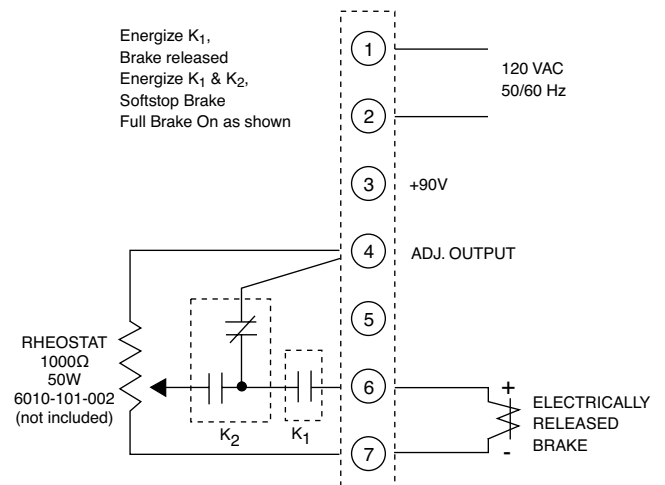

Soft Stop for  
Electrically Released Brake

# Power Supply MCS-805-1, MCS-805-2

The DC voltage required to release the Warner Electric ER-1225 Brake is supplied by the MCS-805-1 or MCS-805-2 Power Supply. The correct brake release voltage—approximately 35-75 volts DC—is set by adjusting the power supply at the time of brake installation. Temperature compensating circuits provide proper operation over the entire operating range of 0°F to 150°F. Switching may be provided on either the AC or DC side of the power supply. The MCS-805-1 may be mounted on its back panel or on 1/2" conduit. The MCS-805-2 has a torque adjustment capability for soft stop applications. The MCS-805-2 requires two switching circuits when used for those applications requiring soft engagement.

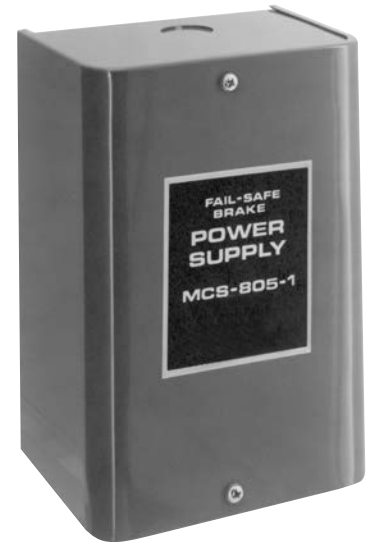

## Specifications

|                                    | MCS-805-1  | MCS-805-2                    |
|------------------------------------|--|------------------------------|
| Part No.                           | 6090-448-006   | 6090-448-007                 |
| Input                              | 115/230 VAC, 50/60 Hz ±10%   | 115/230 VAC, 50/60 Hz ±10%   |
| Output                             | 0.4 Amp, 35/75 VDC   | 0.4 Amp, 35/75 VDC           |
| Ambient Temperature                | -20° to 150°F (-29° to 65°C)   | -20° to 150°F (-29° to 65°C) |
| Maximum Cycle Rate                 | Limited by the clutch or brake and will vary with application. Consult factory for specifics.  |                              |
| External Switches (User furnished) | For DC switching: single pole, single throw. Minimum contact rating 1 amp, 120 volts DC resistive.<br>For AC switching: single pole, single throw. Minimum contact rating 1 amp, 120 volts AC. |                              |
| Circuit Protection                 | .75 Amp 250V Slow Blow 3 AG  |                              |

## Dimensions

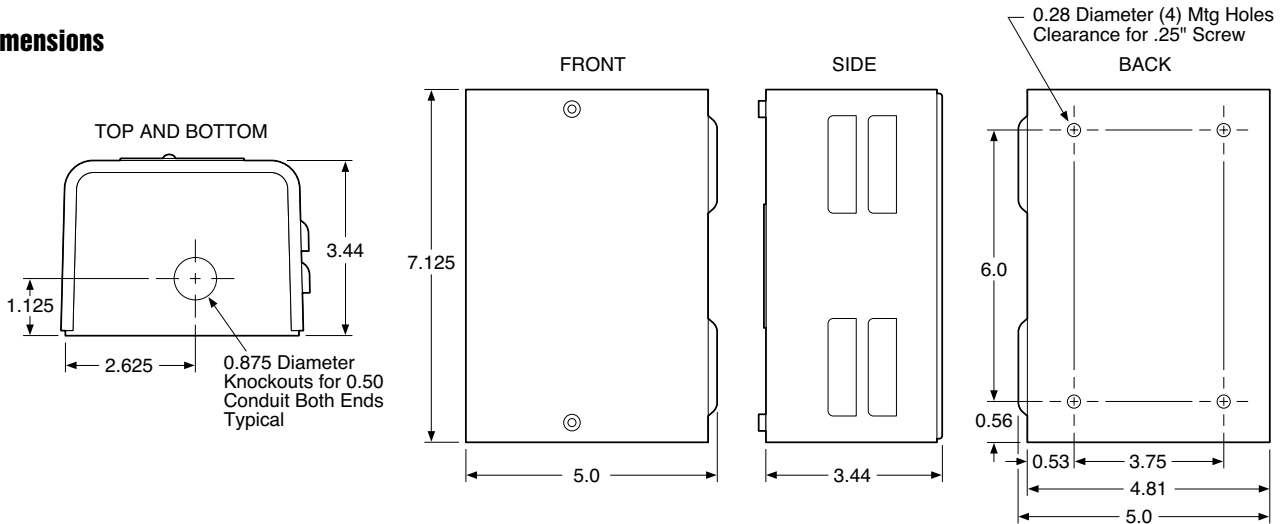

## Connection Diagram

Connect the MCS-805-1 or MCS-805-2 Power Supply per the following diagram and instructions:

**MCS 805-1**

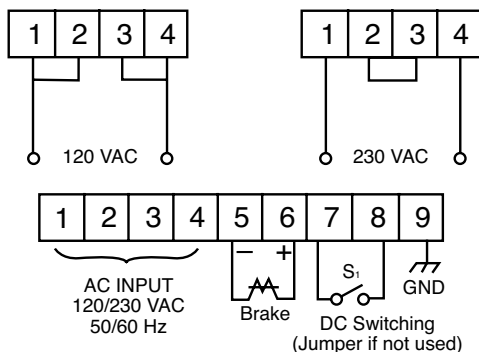

**MCS 805-2**

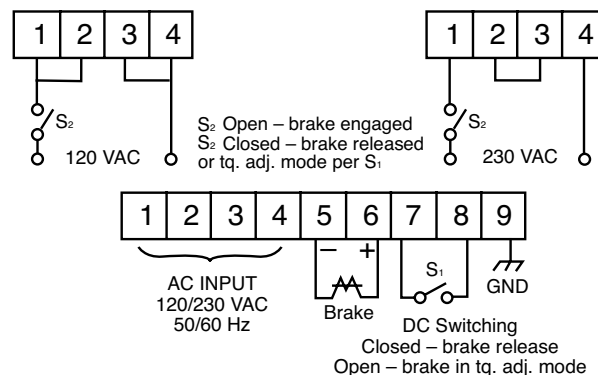



For AC switching, switch may be in series with input supply.  
For DC switching, use terminals 7 and 8 as shown.  
DO NOT put switch in series with load on terminals 5 and 6.

# Adjustable Torque Controls **CBC-200, CBC-300**

## Single or Dual Channel Adjustable Torque Control

The CBC-200 and CBC-300 Controls provide single/dual torque control when connected to any of Warner Electric's 90 volt clutches and brakes.

### Common features

-  and 
- Current monitored output maintains consistent torque regardless of variation in coil temperature.
- Switch selection tunes control to exactly match power requirements and operating characteristics of each clutch or brake.
- Individual torque adjust allows preset maximum torque tailored to application requirements.
- Short circuit protection, line to line.
- Torque limiting protects machine components from damage.
- Can be used with electrically released brakes.



### CBC-200 Dual channel/Single channel torque adjust

The CBC-200 is a dual channel control with one adjustable current and one fixed voltage.

### CBC-300 Dual channel/Dual channel torque adjust

The CBC-300 has two adjustable current channels.

### Specifications

|   | CBC-200 (Obsolete)  | CBC-300                  |     |     |     |
|---|---|--------------------------|-----|-----|-----|
| Part No.  | 6011-448-001  | 6021-448-001             |     |     |     |
| Input Power                                     | 120 VAC +10% -15%, 50/60 Hz, single phase, 215 VA max.  |                          |     |     |     |
| Output  | Pulse-width modulated full wave rectified D.C. Constant current, switch selectable ranges, 0-90 volt  |                          |     |     |     |
| Ambient Temperature                             | +32°F to +113°F (0°C to 45°C) with plastic cover installed<br>+32°F to +150°F (0°C to 66°C) with plastic cover removed  |                          |     |     |     |
| Circuit Protection                              | Internal line to line short circuit protection<br>Optional customer supplied fusing on A.C. line, 1.5 Amps, 250 VAC.<br>Fast-acting fuse recommended  |                          |     |     |     |
| Current Adjust (via front panel potentiometers) | Single adjustable channel   | Dual adjustable channels |     |     |     |
| Status indicators                               | "POWER"—green LED indicates A.C. power is applied to the control.<br>"SHORT"—red LED indicates a short circuit condition exists on one or both outputs.   |                          |     |     |     |
| Internal Adjustments                            | Set DIP switches SW1 and SW2 to suit the current draw of the connected clutch/brake coil:   |                          |     |     |     |
| Switch Range                                    | 1   | 2                        | 3   | 4   | 5   |
| Max Current Draw (mA)                           | 60  | 175                      | 245 | 305 | 533 |
| External Switching                              | Mechanical or electromechanical—customer supplied:<br>1 Amp, 125 V minimum rating<br>Solid-state, NPN isolated transistor—customer supplied:<br>2 Amp, J250 V minimum rating. Maximum off state leakage current <1 mA |                          |     |     |     |

### Dimensions

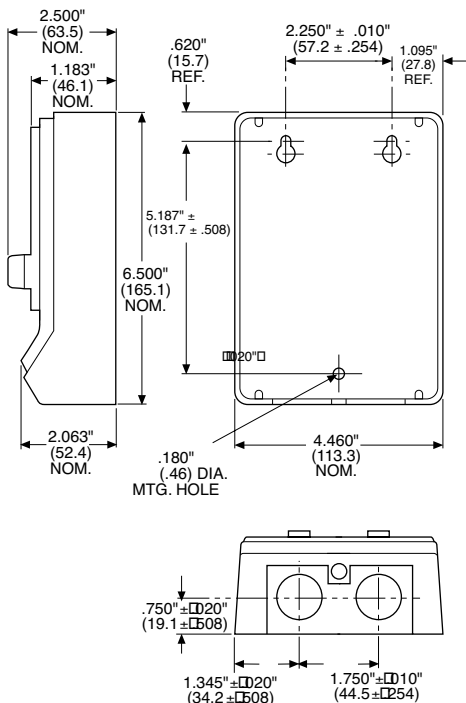

### Connection Diagram

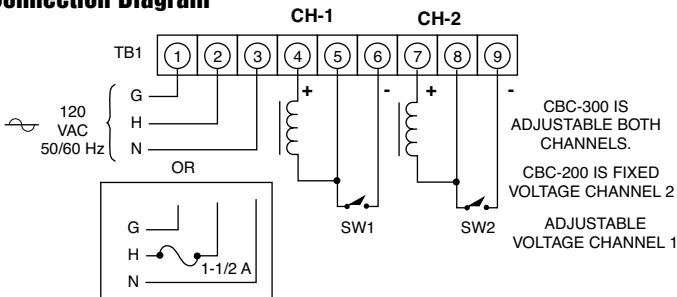

# Adjustable Torque Controls **CBC-500**

## Panel Mounted

### CBC-500 series Dual torque adjustable power supplies

The CBC-500 series is a dual channel adjustable voltage control with optically isolated input switching for 24 and 90 volt electric clutches and brakes. These controls can be set up to energize the two outputs alternately (single) or simultaneously (dual). Refer to the Appendix page 282 for additional setup and switching information.

- Dual adjustable channels
- Optically isolated input switching
- Single or dual channel operation
- Auxiliary 12V supply
- Can be used with electrically released brakes

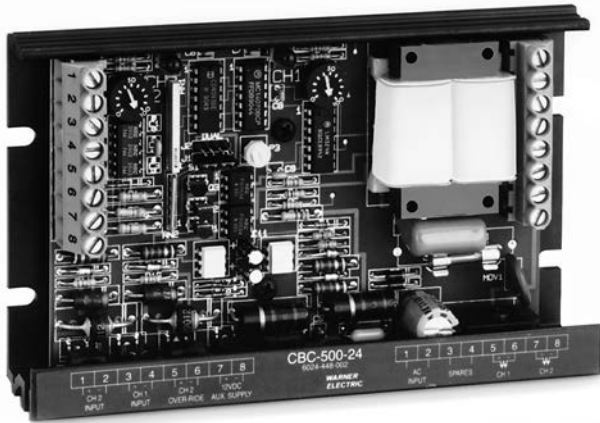

### Specifications

|                     | CBC-500-90  | CBC-500-24                       |
|---------------------|---|----------------------------------|
| Part No.            | 6024-448-003  | 6024-448-002                     |
| Input Voltage       | 120 VAC   | 24-30 VAC                        |
| Output Voltage      | 0-90 VDC  | 0-24 VDC                         |
| Output Current      | 1 Amp/Channel<br>2 Amps Total   | 5 Amps/Channel<br>5 Amps Total   |
| Auxiliary Supply    | 12 VDC 250 mA   | 12 VDC 250 mA                    |
| Circuit Protection  | Fused<br>2.5 Amp, 250 V Fast-blo  | Fused<br>6.3 Amp, 250 V Fast-blo |
| Ambient Temperature | +32° to 122°F (0° to 50°C)  |                                  |
| Status Indicators   | Red LED indicates channel is energized.   |                                  |
| Adjustments         | Two potentiometers for voltage adjustment of channel 1 and channel 2 output from 0 to full rated voltage. Frequency adjustment from 60 to 400 Hz to reduce clutch/brake "Hum" associated with machine frequencies. Jumper for single or dual operation. See appendix on page 282 for explanation. |                                  |
| Inputs:             | 3 Optically coupled, 10-30 VDC, 3-9 mA for Channel 1, Channel 2 and Channel 2 override (applies full voltage to channel 1 output)   |                                  |

### Enclosure (Optional)



- Lift off hinge
- Quick-release latches
- Conforms to NEMA Type 13
- European Standard IEC 529, IP65

| Part No. | 6042-101-004                                  |
|----------|---|
| Size     | 8"H x 6"W x 4"D<br>(203.2 x 152.4 x 101.6 mm) |

### Connection Diagram

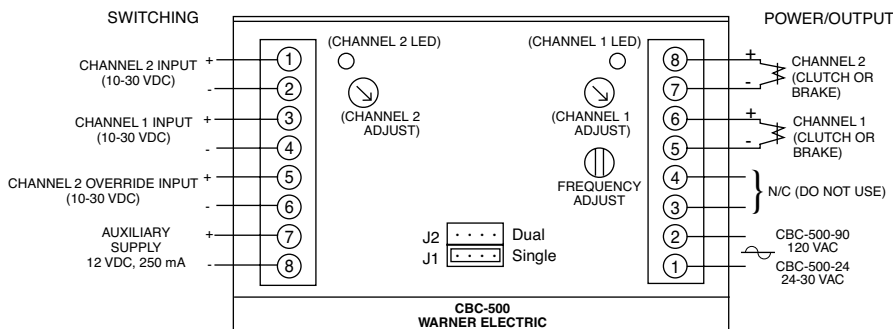

All dimensions nominal unless otherwise specified.

### Dimensions

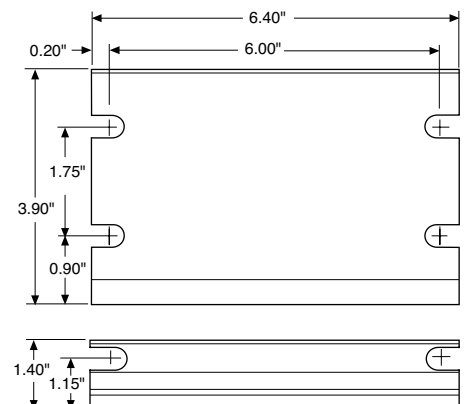

# Adjustable Torque Controls **CBC-550**

## Panel Mounted

### CBC-550 series Dual adjustable with power transformer

The CBC-550 series is a dual channel adjustable voltage control with optically coupled switching for 24 and 90 volt electric clutches and brakes. These controls can be set up to energize the two outputs alternately (single) or simultaneously (dual). Refer to the Appendix page 282 for additional setup and switching information.

The CBC-550 series has a power transformer which will operate with a 120, 220, 240, 380, or 480 VAC input.

- Dual adjustable channels
- Optically isolated input switching
- Single or dual channel operation
- Can be used with electrically released brakes

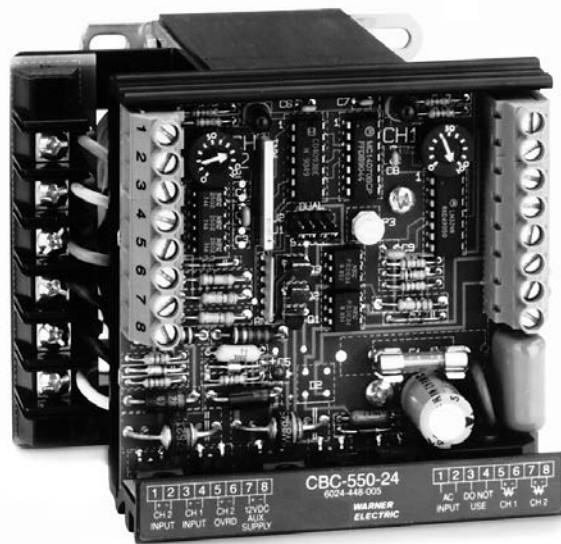

### Specifications

|                     | CBC-550-90  | CBC-550-24                     |
|---------------------|---|--------------------------------|
| Part No.            | 6024-448-006  | 6024-448-005                   |
| Input Voltage       | 120/220/240/380/480 VAC   |                                |
| Output Voltage      | 0-90 VDC  | 0-24 VDC                       |
| Output Current      | 1 Amp/Channel<br>1.2 Amps Total   | 4 Amps/Channel<br>4 Amps Total |
| Auxiliary Supply    | 12 VDC 250 mA   | 12 VDC 250 mA                  |
| Circuit Protection  | Fused<br>1.5 Amp, 250 V fast-blo  | Fused<br>5 Amp, 250 V fast-blo |
| Ambient Temperature | +32° to 122°F (0° to 50°C)  |                                |
| Status Indicators   | Red LED indicates channel is energized.   |                                |
| Adjustments         | Two potentiometers for voltage adjustment of channel 1 and channel 2 output from 0 to full rated voltage. Frequency adjustment from 60 to 400 Hz to reduce clutch/brake "Hum" associated with machine frequencies. Jumper for single or dual operation. See appendix on page 282 for explanation. |                                |
| Inputs              | 3 Optically coupled, 10-30 VDC, 3-9 mA for Channel 1, Channel 2 and Channel 2 override (applies full voltage to channel 1 output)   |                                |

### Enclosure (Optional)



- Lift off hinge
- Quick-release latches
- Conforms to NEMA Type 13
- European Standard IEC 529, IP65

| Part No. | 6006-101-007                                  |
|----------|---|
| Size     | 6"H x 6"W x 6"D<br>(152.4 x 152.4 x 152.4 mm) |

# Adjustable Torque Controls **CBC-550**

**Panel Mounted**

## Dimensions

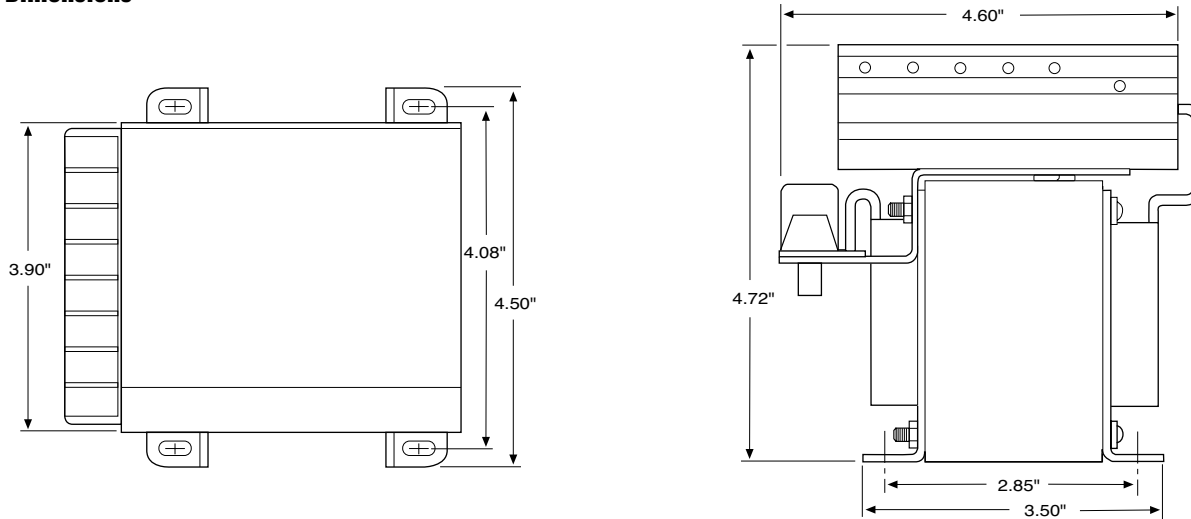

## Connection Diagram

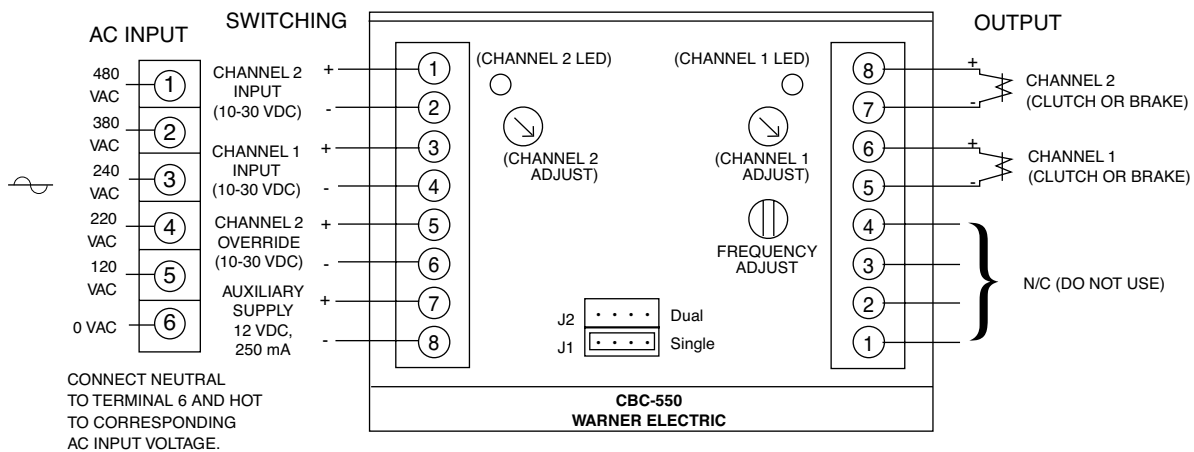

All dimensions nominal unless otherwise specified.

# Adjustable Torque Controls **CBC-1825R**

## Panel Mounted

### CBC-1825R series

The CBC-1825R is designed to provide consistent and repeatable acceleration and deceleration when used with Warner Electric 90 VDC clutches and brakes. Current to each channel is introduced along an adjustable time ramp and monitored continuously. Adjustments include initial pull-in pulse, hold level, maximum torque, and ramp time. LEDs are provided on the circuit board to indicate power is applied to the clutch or brake unit.

**Note:** It is recommended that the auto-gap springs be removed from the clutch and brake for successful accel-decel application.

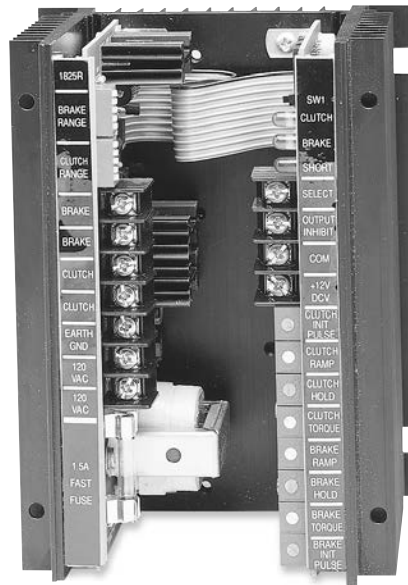

### Connection Diagram

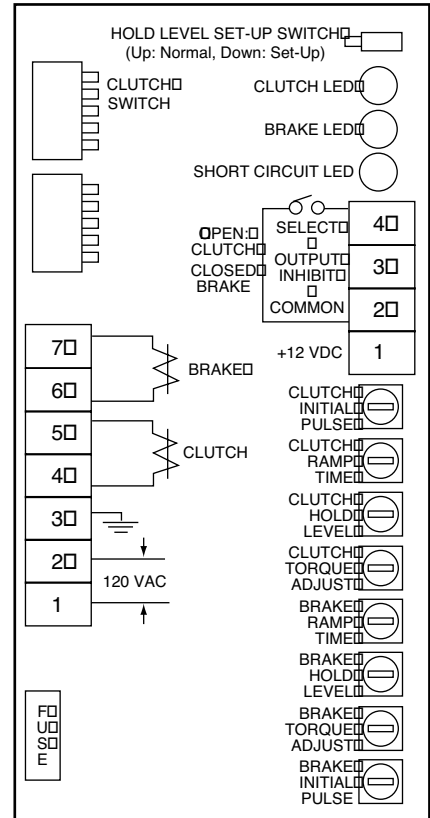

FRONT VIEW

### Specifications

| CBC-1825R           |  |
|---------------------|--|
| Part No.            | 1825-448-001   |
| Input Voltage       | 120 VAC, 50/60 Hz, 100 VA maximum  |
| Output Current      | Current driven PWM, compatible with 90 VDC clutch/brake (switch selectable current output)                                   |
| Auxiliary Supply    | 12 VDC 250 mA  |
| Circuit Protection  | Input Fused 1.5 Amp, 250 V fast-blo<br>clutch and brake outputs are short circuit protected                                  |
| Status Indicators   | Clutch and brake LEDs indicate output is energized<br>Short circuit LED indicates a fault                                    |
| Ambient Temperature | 0° to 122°F (-18° to 50°C)   |
| Switching           | Contact rating: 15 mA @ 15 V, open collector NPN 2mA maximum<br>allowable leakage current and 2 V maximum saturation voltage |

### Dimensions

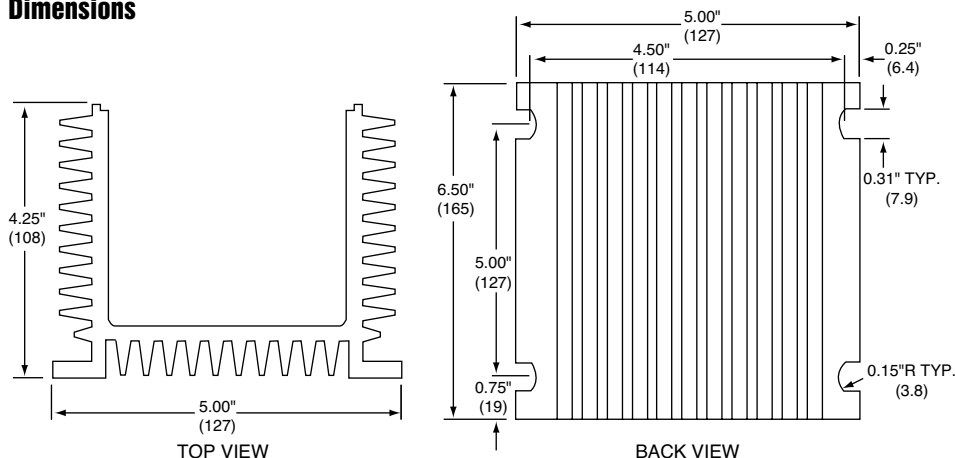

### Set-up

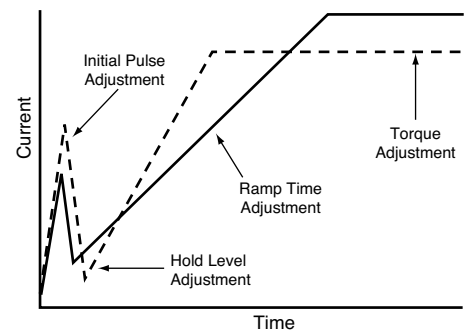

All dimensions nominal unless otherwise specified.



# Overexcitation Controls **CBC-700**

## General Purpose OEX Control

### CBC-700 series

Simple, compact, high performance OEX control for either 90 or 24 VDC clutches and brakes. OEX spike duration and anti-overlap times delay are adjustable. Two optically isolated inputs.

- High performance
- Switch selectable OEX duration
- Force decay suppression with adjustable anti-overlap time delay
- Compact, flexible mounting
- Models for 24 or 90 volt clutches and brakes
- Cycle rate limited by clutch/brake



### Enclosure (Optional)



- Lift off hinge
- Quick-release latches
- Conforms to NEMA Type 13
- European Standard IEC 529, IP65

|                 |   |
|-----------------|---|
| <b>Part No.</b> | <b>6042-101-004</b>                           |
| Size            | 8"H x 6"W x 4"D<br>(203.2 x 152.4 x 101.6 mm) |

### Specifications

|   | <b>CBC-700-90</b>   | <b>CBC-700-24</b>      |
|---|---|------------------------|
| Part No.                                    | 6042-448-003  | 6042-448-002           |
| Input                                       | 120 VAC, 50/60 Hz   | 24-28 VAC, 50/60 Hz    |
| Output Voltages                             |   |                        |
| Steady State                                | 90 VDC  | 24 VDC                 |
| Overexcitation                              | 340 VDC   | 105 VDC                |
| Output Current<br>(Per channel alternately) | .5 Amps   | 3.5 Amps               |
| OEX Pulse Duration                          | Adjustable through logic board dip switches<br>(see service manual) |                        |
| Inputs                                      | Two-optically isolated (10-30 VDC)                                  |                        |
| Ambient Temperature Range                   | 0°F to 140°F (-18°C to +60°C)                                       |                        |
| Maximum Off State Leakage                   | <2 mA (inputs)  |                        |
| Circuit Protection                          | 1.6A Fast Act (5 x 20 mm)   | 5A Slo-Blo (5 x 20 mm) |
| Auxiliary Supply                            | 12 VDC, 250 mA maximum  |                        |

### Connection Diagram

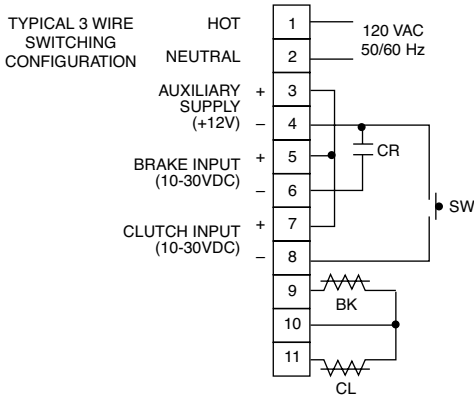

**NOTE:** CR, SW user furnished switch options for use with control.  
CR normally open relay contact  
SW normally open push button switch

### Dimensions

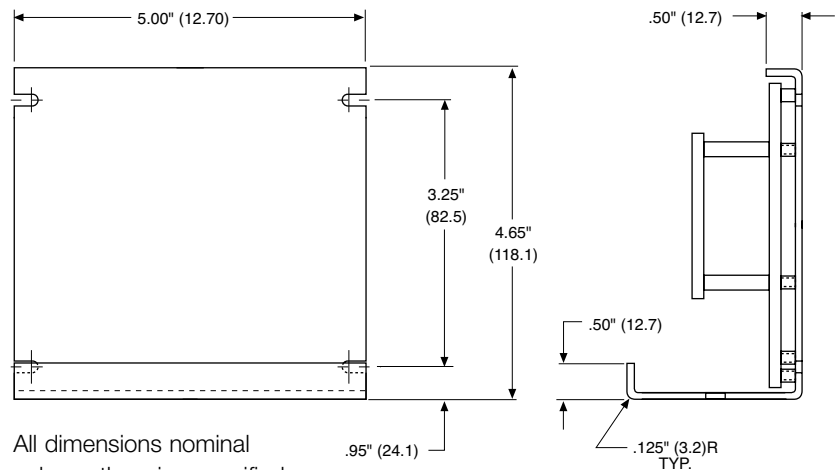

All dimensions nominal unless otherwise specified.

# Overexcitation Controls **CBC-750**

## Rapid Acceleration/Deceleration

### **CBC-750 series** **Dual channel, current based OEX with switching logic**

Warner Electric's CBC-750 series of Constant Current Overexcitation Clutch/ Brake Controls are solid-state electronic controls designed to increase the cycle rate capabilities and accuracies of electromagnetic clutches and brakes. The controls accomplish this by sending a momentary high voltage overexcitation spike to the clutch and/or brake magnetic coil to build a high density magnetic flux field almost instantaneously. By using overexcitation, the response time is reduced as dramatically as performance is increased. For example, the current build up time of a 5 inch, 6 volt magnet is reduced from 84 milliseconds to 2 milliseconds.

The CBC-750 user selects either 120, 220 or 240 VAC operation at the time of installation. Models for 6 volt, 24 volt, or 90 volt clutches and brakes are available.

- High performance OEX control
- Constant current output capability
- Models for 6, 24, and 90 V clutches and brakes
- Outputs short circuit protected.
- AC/DC optically isolated inputs
- Transformer isolation  
Remote torque potentiometer capability
- Input/Output inhibit functions
- Switch selectable OEX function
- Automatic CH1/CH2 anti-overlap feature
- Heavy duty suppression circuits
- Selectable output current ranges
- Remote status indicators inputs and outputs



Shown with optional cover, part number 6041-101-004

LED indicators on the faceplate of each control tell the user the status of input signals, output activation and any auxiliary inputs. A reset switch resets the output should a short be detected. Remote torque adjust potentiometer inputs are also provided. Appropriate current range for each size clutch or brake is selected by a dip switch. Constant current for each level is assured by the control's design.

- Maintains torque at preset levels regardless of temperature variations
- Automatically controls OEX pulse duration for optimum response without overheating coils
- Automatically prevents clutch and brake "overlap"
- Configurable as an analog follower control through remote top input
- Integral switching logic through auxiliary, inhibit and override inputs

### Specifications

|                             | <b>CBC-750-6</b>   | <b>CBC-750-24</b>    | <b>CBC-750-90</b>    |
|-----------------------------|--|----------------------|----------------------|
| Part No.                    | 6041-448-001   | 6041-448-002         | 6041-448-003         |
| Input Power                 | 120/220/240 VAC, ±10%, 50/60 Hz, 350 VA (switch selectable)  |                      |                      |
| Control Inputs              | Opto-isolated 10-30 VDC @ 10-35 mA nominal sinking or sourcing, or 24 VAC (50/60Hz) @ 22 mA nominal, or 120 VAC (50/60 Hz) @ 20 mA nominal |                      |                      |
| Clutch/brake Output         |  |                      |                      |
| Steady State Output         |  |                      |                      |
| Current controlled          | .910 to 4.34 A max.  | .227 to 1.175 A max. | .060-.310 A max.     |
| Current Rise Time           | Dependent on clutch/brake size   |                      |                      |
| Current Fall Time           | Depending on clutch/brake size   |                      |                      |
| Overexcitation Voltage      | 75 VDC nom.  | 240 VDC nom.         | 450 VDC nom.         |
| Overexcitation Time         | Automatic adjustment by control feedback   |                      |                      |
| Anti-overlap Time           | Automatic adjustment by control feedback   |                      |                      |
| Power Supply Output         | 12 VDC, ±0.6 VDC, 250 mA max.  |                      |                      |
| Auxiliary Indicator Outputs | Opto-isolated NPN transistors<br>24 VDC maximum, 20 mA max., reverse polarity protected  |                      |                      |
| Circuit Protection          | Internal short circuit protection on each output channel.  |                      |                      |
| Fusing                      |  |                      |                      |
| AC Input Line               | 2 Amp, 250 V Slo-Blo   |                      |                      |
| OEX Supply                  | 10 Amp, 32 V Slo-Blo   | 5 Amp, 250 V Slo-Blo | 1 Amp, 250 V Slo-Blo |

# Overexcitation Controls **CBC-750**

## Rapid Acceleration/Deceleration

Seven optically isolated inputs accept 10-30V A.C./D.C. (TB2) or 120 VAC (TB3), configured through set-up switches

1. Channel 2 Input
2. Channel 2 Input Inhibit (disregards channel 2 input signal)
3. Auxiliary Input
4. Channel 1 Input
5. Channel 1 Input Inhibit (disregards channel 1 input signal)
6. Output Inhibit (deactivates both output channels)
7. Channel 2 Override (applies full voltage to channel 1 output)

### Connection Diagram

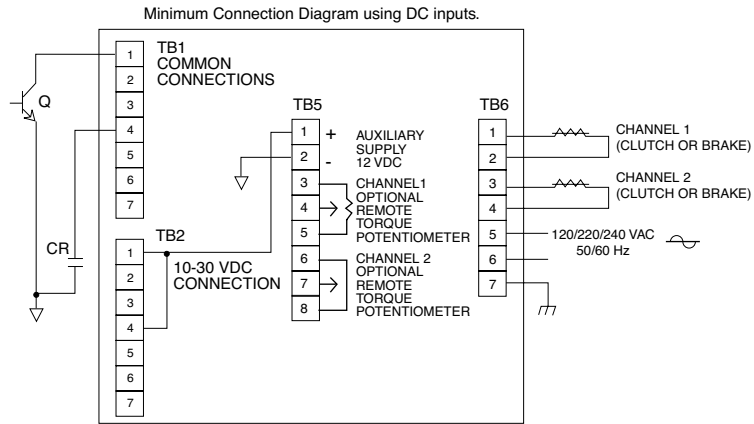

### Dimensions

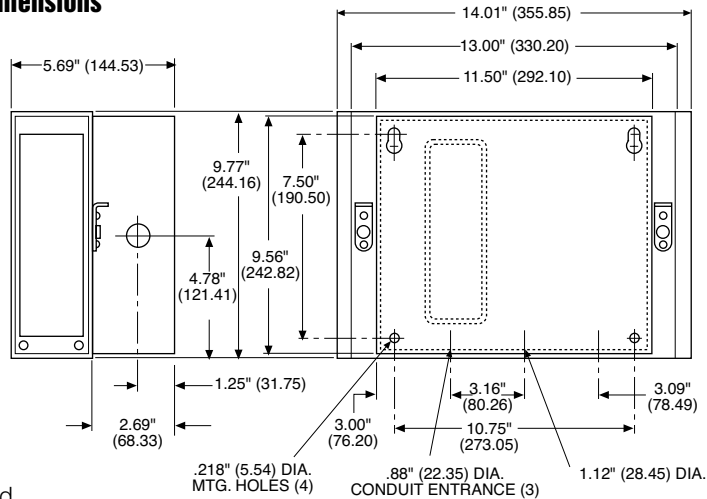

### Setup Switches

SW1: AC Voltage selection switch on terminal board inside control unit

### Max. Current Output

(SW7 & SW8 settings)

| Nominal Voltage | 1     | 2     | 3     | 4     | 5     |
|-----------------|-------|-------|-------|-------|-------|
| 6               | 0.910 | 2.35  | 3.183 | 3.760 | 4.340 |
| 24              | 0.227 | 0.641 | 0.881 | 0.940 | 1.175 |
| 90              | 0.060 | 0.176 | 0.256 | 0.282 | 0.310 |

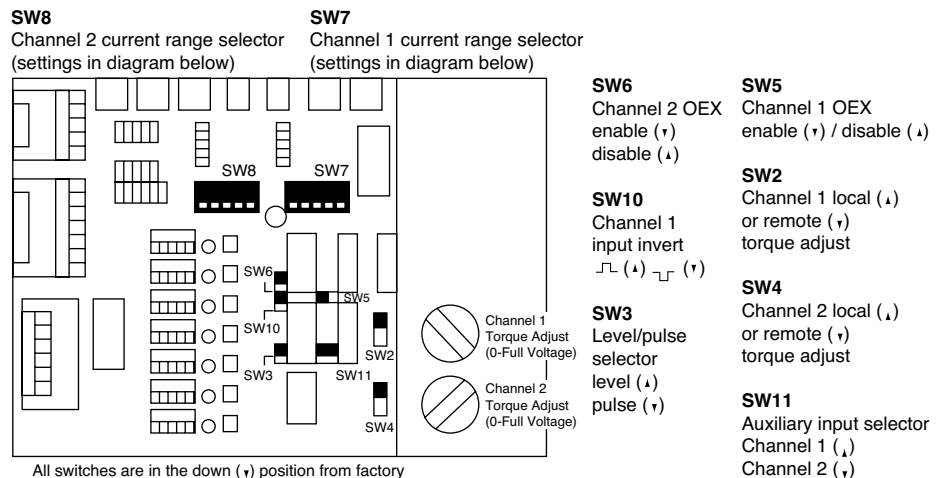

# Closed Loop Position Control **CBC-1000**

## System Accuracy

### CBC-1000

#### Position-loop control with error correction compensation

Warner Electric's CBC-1000 is a closed-loop positioning control with error compensation designed for industrial clutch/brake applications. The position loop is closed through encoder feedback which generates pulses proportional to load motion. The CBC-1000 uses this feedback to determine the optimum brake actuation point. The control can be programmed to operate in one of two distinct modes: absolute or incremental. The CBC-1000 includes eight solid state control outputs, a batch counter and a serial communications interface.

The CBC-1000 system consists of four key elements: the CBC-1000, a clutch/brake, a clutch/brake control, and an encoder. Nearly any electric clutch/brake size and configuration can be used. The clutch/brake control should have solid-state compatibility. Simple on-off, soft start/stop, and overexcitation controls may all be utilized based on the desired velocity profile.

### Accessories

| Description                                   | Part Number  |
|---|--------------|
| Encoder Cable (Accessory)                     | 6060-101-001 |
| Encoder Cable (Accessory)<br>7 Pin for marker | 6060-101-002 |
| 100 PPR Encoder w/10' cable                   | 6060-101-010 |
| 250 PPR Encoder w/10' cable                   | 6060-101-025 |
| 600 PPR Encoder w/10' cable                   | 6060-101-060 |
| 600 PPR w/marker & 10' cable                  | 6060-101-061 |
| 1200 PPR Encoder w/10' cable                  | 6060-101-120 |
| 2500 PPR Encoder w/10' cable                  | 6060-101-250 |
| 5000 PPR Encoder w/10' cable                  | 6060-101-500 |

(PPR—Pulse Per Revolution)

### Serial Interface Module



Performs the necessary voltage level conversions to interface the RS-422A/485 output of the CBC-1000 to RS-232C equipment.

Part Number: 6060-101-232



### Specifications

|                       |  |
|-----------------------|--|
| <b>Part No.</b>       | <b>6060-448-001</b>  |
| Input Power           | 100 to 130 VAC, 50/60 Hz, 20VA (200 to 260 VAC selectable) |
| Auxiliary Supply      | 12 VDC @ 175 mA Used for powering encoder, etc.            |
| Main Counter          |  |
| Range                 | 6 Decades  |
| Reset Input           | External and front panel                                   |
| Count Rate            | (20 kHz external input frequency)                          |
| Batch Counter         |  |
| Range                 | 6 Decades  |
| Reset                 | Through front panel only                                   |
| Signal A and B Inputs |  |
| Input Frequency       | D.C., 20 kHz quadrature max.                               |
| Input High Level      | 3.25 VDC min.  |
| Input Low Level       | 1.75 VDC max.  |
| Control Inputs        |  |
| Input Frequency       | D.C. to 20 Hz max. each input                              |
| Input Type            | Single ended, current sinking                              |
| Input Logic           | Both Edge and Level sensitive as defined by input use      |
| Input High Level      | 10 VDC min. to 20 VDC max.                                 |
| Input Low Level       | 0 VDC min. to 2 VDC max.                                   |
| Input Current         | 2.5 mA steady state  |
| Display               |  |
| Decades               | 7 Decade, 0.6" red LED                                     |
| Decimal Point         | User programmable<br>Range: xxx.xxx to xxxxxx              |
| Program Security      | Program LOCK of lines 1 - 33                               |
| Control Outputs       |  |
| Type                  | 8 Solid State 100 mA sink max., 24 VDC max.                |
| Serial Interface      |  |
| Type                  | RS-422A/485 compatible                                     |
| Baud Rate             | Selectable: 300, 600, 1200, 2400                           |
| Parity                | Selectable: None, Odd, Even                                |
| Data                  | ASCII  |
| Diagnostics           | Nine Self-Test Diagnostics                                 |
| Mechanical            |  |
| Enclosure             | Aluminum extrusion with molded VALOX bezel.                |
| Weight                | 2.5 lbs.   |
| Environmental         |  |
| Operating Temp.       | 0° to +50°C (32° to 122°F)                                 |
| Storage Temp.         | -18° to 85°C (0° to 186°F)                                 |
| Ambient Humidity      | 90% and noncondensing                                      |

## CBC-1000 Application Procedure

### 1. Select the proper clutch/brake

- Determine torque and inertia requirements
- Calculate heat dissipation for required cycle rate
- For best accuracy, mount clutch/brake directly on nip or drive shaft; avoid backlash

### 2. Select quadrature encoder

- Select encoder PPR for desired system resolution (i.e. inches/pulse, degrees/pulse, etc.)
- Determine input frequency; do not exceed 20,000 pulses/sec.
- Mount encoder directly to nip or drive shaft for best accuracy

### 3. Select clutch/brake power supply

- Use CBC-700 overexcitation control for best accuracy
- Use CBC-500/550 for soft starting and/or stopping
- Brake autogap may have to be removed for best accuracy

### 4. Plan system logic (switching requirements)

- Use absolute mode for indexing applications such as conveyors and turntables or cutoff applications where close registration is required
- Use incremental mode for cutoff applications
- Determine switching and relays required for machine operation

### 5. Select serial interface module if applicable.

### Timing Diagram

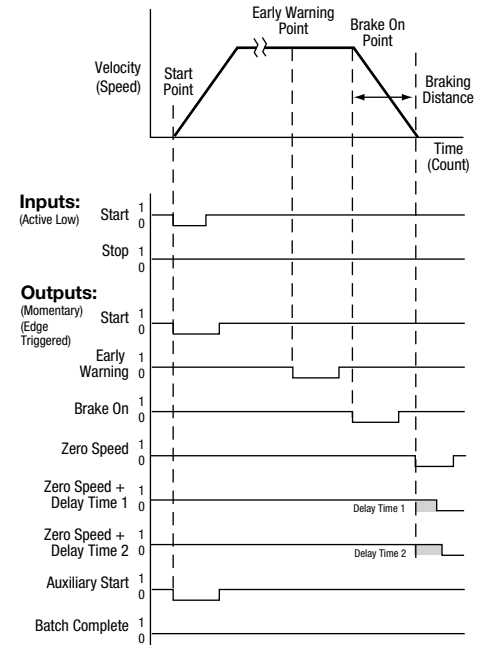

### Operation

Successful operation will require knowledge of the following definitions and their relationships to the timing diagram.

### Function Key Definitions

|                  |              |  |
|------------------|--------------|--|
| Count            | 1<br>COUNT   | The actual move distance, in pulses or scaled into engineering units (inches, feet, rotations, degrees, etc.) displayed dynamically.   |
| Move Present     | 2<br>MOV PST | The desired move distance in pulses or scaled into engineering units. This is the value the operator enters to select a new move distance.   |
| Early Warning    | 3<br>E.W.    | A distance prior to Move Preset at which the early warning output is activated. Expressed as pulses or engineering units, this output can be used to accomplish a soft brake (slow down), energize valves, etc.  |
| Batch            | 6<br>BATCH   | A cumulative batch counter that can be dynamically displayed to show the number of operations, cycles, etc. When this counter reaches the value programmed by the Batch Preset (key 7) the Batch Complete Output is activated. The batch counter can be manually or automatically reset.   |
| Batch Preset     | 7<br>BCH PST | A programmable batch counteractivates the batch complete output when the value programmed has been reached by the batch (key 6)  |
| Braking Distance | 8<br>BRK DIS | The actual distance required to stop. This value is dynamically updated to determine the brake actuation point. Factory default is 25 pulses or engineering units which is only used for the first cycle after power-up. After the first cycle the CBC-1000 will tune to the particular brake being utilized. The amount of cycles needed for tuning depends on how far the true braking distance value is from the default of 25. |

# Appendix

## CBC-400/450/500/550 Single vs Dual Operation

The CBC 400 and 500 series controls allow operation in either a single or dual mode. The mode of operation is determined via the position of a jumper on the main control board.

The controls are shipped with the jumper in the J1 or single mode position. A variety of output logic can be accomplished via the single/dual jumper position and whether the control is wired to one input switching device (2-wire mode) or two input switching devices (3-wire mode). The following diagrams show how each channel (output) of the control can be either alternately or simultaneously energized.

### 2-wire Switching Option

#### Control's switching terminal block

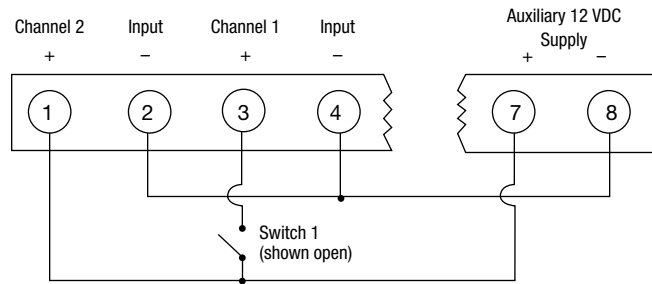

| Jumper Mode | Switch 1 | Channel 1 | Channel 2 |
|-------------|----------|-----------|-----------|
| J1-Single   | Open     | Off       | Powered   |
|             | Closed   | Powered   | Off       |
| J2-Dual     | Open     | Powered   | Powered   |
|             | Closed   | Off       | Off       |

### CBC-500/550

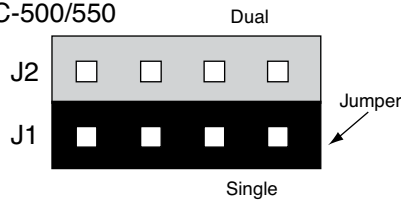

### CBC-400/450

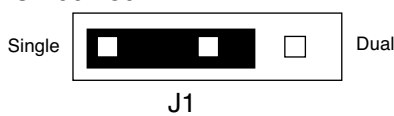

### 3-wire Switching Option

#### Control's switching terminal block

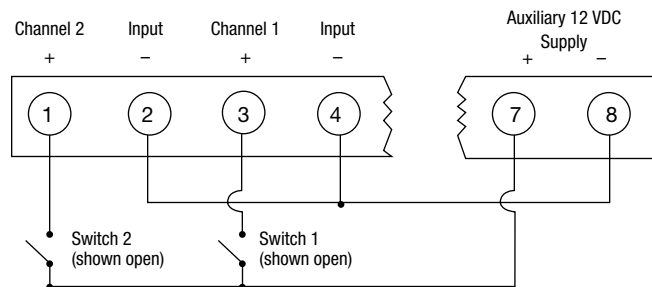

| Jumper Mode | Switch 1 | Switch 2 | Channel 1  | Channel 2  |
|-------------|----------|----------|------------|------------|
| J1-Single   | Closed   | Open     | Latched On | Off        |
|             | Open     | Closed   | Off        | Latched On |
| J2-Dual     | Closed   | Open     | Off        | Off        |
|             | Open     | Closed   | Latched On | Latched On |

**1. What transformers can be used with controls requiring 24-30 VAC input?**

| Manufacturer | Part Number | Primary     | Secondary    |
|--------------|-------------|-------------|--------------|
| Abbott       | 6B 12-160   | 115 VAC     | 24V @ 6 amps |
| Quality      | 6-K-119VBR  | 115/230 VAC | 24V @ 8 amps |
| Signal       | 24-6        | 115 VAC     | 24V @ 6 amps |
| Signal       | DP24-6      | 115/230 VAC | 24V @ 6 amps |
| Triad        | F-260-U     | 115 VAC     | 24V @ 6 amps |

**2. When a single clutch or brake is used with a CBC-200 and no switch is used, a jumper wire is required across terminals 5 & 6 to get output at terminals 4 & 5.**

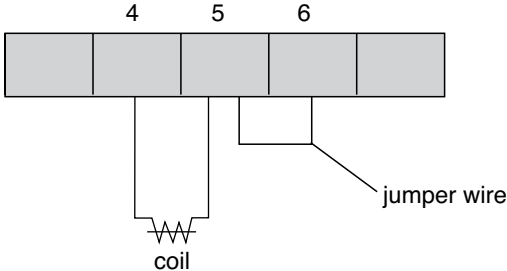

**3. What is the difference between a MCS-801 and a CBC-801-1 or between a MCS-103 and a MCS-103-1?**

There is no performance difference between the MCS-103 and MCS-103-1. There is no performance difference between the MCS-801 and CBC-801-1. The CBC-801-1 is roughly 1/4" shorter than the MCS-801. The units wire and work exactly the same.

**4. Which power supplies can be used with the SF 1525HT and SFC 1525HT coil?**

The SF and SFC 1525 High Torque clutch coils require .794 amps of current to provide full rated torque. The following power supplies and controls will provide the needed power.

|         |           |           |           |
|---------|-----------|-----------|-----------|
| CBC-100 | .8 amps   | CBC-450   | 1 amp     |
| CBC-150 | .8 amps   | MCS-103-1 | 1.25 amps |
| CBC-801 | 1.25 amps | CBC-500   | 1 amp     |
| CBC-400 | 1 amp     | CBC-550   | 1 amp     |

**5. Can I use a CBC-160 with a variable frequency drive and AC motor?**

No. As the voltage to the drive is varied, the output to the electrically released brake would also vary. This would cause the brake to re-engage when it should be released.

**6. Which power supplies offer a 12 VDC power source that could be used to power auxiliary switch inputs such as inductive or photoelectric sensors?**

CBC-400, CBC-450, CBC-500,  
CBC-550, CBC-700, CBC-750

**7. Is the CBC-1000 a stand-alone control?**

No. The CBC-1000 provides closed loop feedback for a clutch/brake system. A common system will consist of four components:

- a Warner Electric brake and clutch
- a Warner Electric power supply
- an Encoder
- a CBC-1000 position control

The application criteria will determine which clutch/brake and which control will be appropriate selections.

**8. Which of the controls would allow for the independent operation of two clutches or two brakes?**

Four controls allow for completely independent operation of two clutches or brakes. That is, that a clutch and brake can both be on at once, both off at once, or one on and one off. These controls are:

CBC-801-1 and CBC-801-2, MCS-103-1, CBC-200, CBC-300

The CBC-400/450 and CBC-500/550 allow for operation of both channels on at once, both channels off at once or cycling between channel one and two. However, in the both-on/both-off mode, you cannot also do independent single channel operation.

**9. Are there any controls that can be used to control the torque of a 90 volt clutch or brake via an analog signal input?**

There are two options we offer, a special TCS-200 or a Bronco drive (B169 or B161s) with a signal follower card. These units can be configured to provide a variable torque output for a clutch or brake based on an analog input signal. Consult the factory for the best solution for your specific application needs.

**10. Which controls can be used with electrically released brakes?**

The CBC-160-1 and CBC-160-2 are designed specifically to use with the conduit box of EM and EUM electrically released brake designs. The CBC-160-1 and CBC-160-2 can also be used with ER and FB brake designs.

The MCS-103-1, CBC-200, CBC-300 and CBC-500/550 can all be used with ER, FB as well as UM-FBC, EM and EUM-FBB and EM and EUM-MBFB designs.

The MCS 805-1 and MCS 805-2 are for use only with the ER 1225 brakes. The ERS series brakes can be used with the CBC-100 or CBC-801 power supplies.

# Ordering Information

---

| Model  | Part Number        | Page |
|--|--------------------|------|
| CBC-100-1 .....  | 6003-448-101 ..... | 264  |
| CBC-100-2 .....  | 6003-448-103 ..... | 264  |
| MCS-103-1 .....  | 6010-448-002 ..... | 270  |
| CBC-150-1 .....  | 6004-448-001 ..... | 264  |
| CBC-150-2 .....  | 6004-448-002 ..... | 264  |
| CBC-160-1 .....  | 6013-448-001 ..... | 265  |
| CBC-160-2 .....  | 6013-448-002 ..... | 265  |
| MCS-153-1 .....  | 6012-448-001 ..... | 271  |
| CBC-200 ( <i>Obsolete, replaced by CBC-300</i> ) ..... | 6011-448-002 ..... | 272  |
| CBC-300 .....  | 6021-448-001 ..... | 272  |
| CBC-400-24 .....                                       | 6006-448-002 ..... | 268  |
| CBC-400-90 .....                                       | 6006-448-003 ..... | 268  |
| CBC-450-24 .....                                       | 6006-448-005 ..... | 269  |
| CBC-450-90 .....                                       | 6006-448-006 ..... | 269  |
| CBC-500-24 .....                                       | 6024-448-002 ..... | 273  |
| CBC-500-90 .....                                       | 6024-448-003 ..... | 273  |
| CBC-550-24 .....                                       | 6024-448-005 ..... | 274  |
| CBC-550-90 .....                                       | 6024-448-006 ..... | 274  |
| CBC-1825R .....  | 1825-448-001 ..... | 276  |
| CBC-700-24 .....                                       | 6042-448-002 ..... | 277  |
| CBC-700-90 .....                                       | 6042-448-003 ..... | 277  |
| CBC-700 Enclosure .....                                | 6042-101-004 ..... | 277  |
| CBC-750-6 .....  | 6041-448-001 ..... | 278  |
| CBC-750-24 .....                                       | 6041-448-002 ..... | 278  |
| CBC-750-90 .....                                       | 6041-448-003 ..... | 278  |
| CBC-801-1 .....  | 6001-448-004 ..... | 266  |
| CBC-801-2 .....  | 6001-448-006 ..... | 266  |
| Octal Socket, Foot Mount .....                         | 6001-101-001 ..... | 266  |
| Octal Socket, DIN Rail Mount .....                     | 6001-101-002 ..... | 266  |
| CBC-802-2 .....  | 6002-448-001 ..... | 267  |
| CBC-1000 .....   | 6060-448-001 ..... | 280  |
| Serial Interface Module .....                          | 6060-101-232 ..... | 280  |
| Encoder Cable (Accessory) .....                        | 6060-101-001 ..... | 280  |
| Encoder Cable (Accessory) 7 Pin for marker .....       | 6060-101-002 ..... | 280  |
| Encoders: 100 PPR .....                                | 6060-101-010 ..... | 280  |
| 250 PPR .....  | 6060-101-025 ..... | 280  |
| 600 PPR .....  | 6060-101-060 ..... | 280  |
| 600 PPR w/ marker .....                                | 6060-101-061 ..... | 280  |
| 1200 PPR .....   | 6060-101-120 ..... | 280  |
| 2500 PPR .....   | 6060-101-250 ..... | 280  |
| 5000 PPR .....   | 6060-101-500 ..... | 280  |
| Optional Enclosure: CBC-400, CBC-500, CBC-700 .....    | 6042-101-004 ..... | 268  |
| Optional Enclosure CBC-450, CBC-550 .....              | 6006-101-007 ..... | 269  |