

Browning[®]

Installation and Maintenance Manual

Rotating Biological Contactor Drives



▲WARNING

Disconnect all power while adjusting units



INSTALLATION AND MAINTENANCE RECORD

Browning suggests that you fill in the nameplate information below from the name plate on the reducer and KEEP THIS MANUAL ON FILE FOR FUTURE REFERENCE ON THIS INSTALLATION.

▲WARNING
 Failure to observe safety precautions could cause personal injury or equipment damage.

EMERSON POWER TRANSMISSION MAYSVILLE, KENTUCKY U.S.A. 41056																									
SIZE _____ SERIAL NO. _____ SERVICE HP. _____ SERVICE FACTOR _____	INPUT RPM _____ RATIO _____ OUTPUT RPM _____																								
RATINGS ARE IN ACCORDANCE WITH STANDARDS OF THE AMERICAN GEAR MANUFACTURERS ASSOCIATION																									
<table border="1" style="width: 100%; border-collapse: collapse;"> <tr> <th colspan="4" style="text-align: center;">AGMA LUBRICANT</th> </tr> <tr> <td colspan="2">AMBIENT</td> <td>15-60° F</td> <td>50-125° F</td> </tr> <tr> <td colspan="4" style="text-align: center;">TEMP.</td> </tr> <tr> <td>AGMA NO.</td> <td>CST AT 104°F</td> <td>AGMA NO.</td> <td>CST AT 104°F</td> </tr> <tr> <td>3</td> <td>90-110</td> <td>4</td> <td>135-165</td> </tr> <tr> <td>4</td> <td>135-165</td> <td>5</td> <td>198-242</td> </tr> </table>		AGMA LUBRICANT				AMBIENT		15-60° F	50-125° F	TEMP.				AGMA NO.	CST AT 104°F	AGMA NO.	CST AT 104°F	3	90-110	4	135-165	4	135-165	5	198-242
AGMA LUBRICANT																									
AMBIENT		15-60° F	50-125° F																						
TEMP.																									
AGMA NO.	CST AT 104°F	AGMA NO.	CST AT 104°F																						
3	90-110	4	135-165																						
4	135-165	5	198-242																						
DRAIN, FLUSH, CLEAN MAGNETIC PLUG AND REFILL WITH NEW OIL EVERY 6 MONTHS OF OPERATION. INSPECT OIL LEVEL FREQUENTLY																									

INSTALLATION

Date: _____

Comments: _____

MAINTENANCE

Date:	Comments — i.e. Oil Change, Grease, etc.

▲WARNING Disconnect all power while adjusting units

Contents

	Page
Handling and Installation	4
Maintenance	4
Lubrication	4
Assembly Instructions	5-6
415SMT-148 Tapered Bush Unit	
415SMF-148 Straight Bore Unit	
Motor Mount	
Belt Guard	
Torque Arm	
Torque Arm Kit Options	7
Assembly Drawing	8
Parts Lists	9



Handling

Units are shipped on pallets. The shaft mounted reducers are tagged at the factory to indicate whether it shipped with or without oil. Upon receipt, all reducers should be checked for damage and to make sure that each unit is supplied with a Motor Mount and Bushing (if SMT style is ordered).

Storage

For periods of inoperation longer than a week, the unit must be operated at least ten revolutions of the output shaft each week that it is idle. This will keep the gear drive well coated with lubricant and prevent rust.

For long term storage, the gear unit should be kept out of the weather in a well ventilated place. The gear unit should also be completely filled with a light oil and rotated every month so that the low speed shaft rotates more than one complete turn.

Installation

Assemble the fill and drain elbows, plugs and level gage as shown on the outline drawing, Page 7. This should be done while the unit is laying flat as some units are shipped with oil. The breather should be installed after the unit is mounted on the shaft to prevent leakage.

The shaft on which the reducer is to be mounted must be straight, clean and free of burrs on the SMF style units. Lubricate the shaft to ease the mounting of the reducer. (Anti-fretting grease is recommended. "Never-Seez"). Do not use a lubricant on the shaft or bushing if installing an SMT style unit. A lifting lug is provided to lift the reducer into position.

WARNING

Lifting lug should only be used to handle the weight of the reducer. Do not use lifting lug to lift attached assemblies. This lifting lug may be repositioned onto any one of the housing flange bolts as required. Make sure all capscrews are reinstalled and torqued to 175-265 FT. LBS."

Slide the reducer on the shaft to its proper position and install the key. Assemble the torque arm and mount the floor support bracket "Torque Arm Fulcrum" to the foundation. When using the standard torque arm kit TA415-RBC/1, position the reducer so that the input shaft and output bore are horizontal. Adjust the position by turning the turnbuckle (see page 7). If the optional torque arm kits are used, install the gear unit and torque arm as shown.

Check the oil level when the reducer is in its operating position. The proper level is the upper plug on the outside of the output quill (see outline drawing at page 7). Add or drain oil to the proper level through the breather hole or drain plug hole respectively. When the proper oil level has been reached, install the breather and/or the drain plug in the locations shown on page 7.

Maintenance

Check oil level on regular basis. Also watch for any oil collection under the reducer.

Seals are maintenance items and may require replacement after several thousand hours operation. If a leak develops, allowing more than one cup of oil per week, the seal should be replaced.

Before removing the worn seals, drain the oil to a level below the affected shaft. Carefully remove the old seal(s) without damaging the seal surface on the shaft. Coat the lip of the replacement seal with oil or grease. Cover any keyways or other sharp edges of the shaft with smooth tape, and slide the new seal up to the housing. Gently work the seal into the housing by tapping circumferentially with a blunt surface. Do not deform the metal seal housing. Add the proper amount of new oil to the correct oil level.

The reducer must be removed from the shaft when changing the inside slow speed seal.

It is recommended that the units be returned to the factory for any internal repairs as all bearings are specifically adjusted. Failure to do so in the field may result in premature gear failure. Contact the factory for any additional information.

WARNING

Disconnect all power while adjusting units

Installation Instructions for Rotating Biological Contactor Unit with Taper Bushing

1. TOOLS NEEDED

Torque wrench
15/16 socket

2. The shaft on which the reducer is to be mounted must be straight, clean and free of burrs. A lifting lug is provided to lift the reducer into position.

▲WARNING

(Lifting lug should only be used to lift the weight of the reducer. Do not use lifting lug to lift attached assemblies to avoid overloading the lifting lug.) This lifting lug may be repositioned onto any one of the housing flange bolts as required. Make sure all capscrews are reinstalled and torqued to 175-265 FT. LBS.

▲WARNING

Never lift reducer by its shafts.

3. Do not grease or oil the taper bore of the reducer, barrel of the bushing or bushing bore.
4. Rotate shaft onto which reducer is to be mounted so keyseat is in the upward position.
5. In most cases, the key supplied will be rectangular or offset. Use caution when installing rectangular keys as some may visually appear to be square. Key should install in bushing keyway with a sliding type fit. Key in shaft keyseat should be retained to prevent movement.
6. Install bushing on shaft, flanged end first. Align keyway in bushing with keyseat in shaft and install shaft key. Position shaft key flush against the inside flange surface of bushing. NOTE: shaft must engage full length of bushing.
7. Position reducer on shaft. Rotate reducer input shaft to align keyway in hollow quill with bushing/shaft key and install reducer on tapered bushing.
8. Rotate bushing ring until tapped holes align with drilled holes in bushing flange. Make sure bushing key is as close as possible to the inside flange of bushing and bushing positioned on shaft as required.
9. Install bushing capscrews and tighten all capscrews evenly to 140 FT. LBS. Capscrews should be tightened in 10 FT.-LB. increments to minimize possibility of bushing misalignment.

▲WARNING

Capscrews must thread into bushing ring and not bushing. Threaded holes in bushing are for removal only. If assembled incorrectly, equipment failure and personal injury may result.

10. Attach torque arm assembly per torque arm instructions.

▲WARNING

Disconnect all power while adjusting units

Installation Instructions for Rotating Biological Contactor Unit with Finish Bore

1. The shaft on which the reducer is to be mounted must be straight, clean and free of burrs. Lubricate the shaft to ease the mounting of the reducer. (Anti-fretting grease is recommended for finished bore only.) A lifting lug is provided to lift the reducer into position.

▲WARNING

(Lifting lug should only be used to lift the weight of the reducer. Do not use lifting lug to lift attached assemblies to avoid overloading the lifting lug.) This lifting lug may be repositioned onto any one of the housing flange bolts as required. Make sure all capscrews are reinstalled and torqued to 175-265 ft. lbs.

▲WARNING

Never lift reducer by its shafts.

2. Rotate the shaft on which the reducer is to be mounted so keyseat is in upward position. Install key in keyseat.
3. The driven shaft should extend all the way through the hollow shaft. Do not hammer on reducer when mounting as this could damage the reducer housing and internal parts.
4. Position reducer on shaft. (Note make sure shaft key engages full length of quill keyway.)
5. Attach torque arm assembly per torque arm instructions.

Motor Mount Assembly Installation Instructions

1. TOOLS NEEDED

1 1/8 Wrench (may be box or open-end)
Two 15/16 wrenches (open-end)

2. With reducer mounted in proper position, the two weld on legs of the motor swing base so they straddle the top of the housing.
3. Line up holes in legs with tapped holes in housing.
4. Install 3/4 capscrews, one on each side. Do not tighten.
5. Thread one of 5/8 nuts onto each of the eyebolts. Thread down about half way.
6. Insert threaded rod into hole at edge of motor swing base plate.
7. Install 3/4 capscrew into hole of eyebolt and thread in tapped hole in housing. Do not tighten.
8. Install 5/8 nut on end of threaded rods.
9. Install motor on swing base and tighten motor bolts.
10. Install motor pulley, reducer pulley and belts.
11. Use 15/16 wrench on nuts/threaded rods to adjust motor plate and obtain proper center distance and belt tension.
12. When proper center distance is achieved, tighten adjusting nuts.
13. Using 1 1/8 wrench tighten swing base and eyebolt capscrews.

Belt Guard Mounting Instructions

TOOLS REQUIRED

Two 7/16" wrenches-may be box-end or open-end
15/16" wrench
1 1/8" wrench
Drill with 5/16" bit
Pen or pencil

1. Install the correct motor on the mounting plate provided with the reducer.
2. Use the 15/16" wrench on the nuts/threaded rods to adjust the motor mounting plate until the correct center distance for the belt drive is obtained.
3. When the correct center distance is achieved, tighten the adjusting nuts.
4. Use the 1 1/8" wrench to loosen the bolts that attach the motor mounting plate and threaded rod to the input side of the reducer. These bolts should be loosened enough to allow the belt guard support brackets to slide between the reducer housing and the bolt head. Do not remove these bolts.
5. When the bolts are loose enough, slide the slotted end of one support bracket behind each bolt head. Align the upper, or motor mount connection, bracket at approximately 5 o'clock for right hand mounting (7 o'clock for left hand mounting). Align the lower, or threaded rod connection, bracket at approximately 2 o'clock for right hand mounting (10 o'clock for left hand mounting). Tighten the bolts until the assemblies are snug, but not tight.
6. Pick up the belt guard half with the motor and shaft holes. Fit the belt guard half over the motor and reducer shafts. The slot should fit over the motor shaft and the round bore over the reducer shaft.
7. Manually adjust the support brackets and belt guard half so that the following criteria are met:
 - a) The belt guard half does not rub against the motor shaft.
 - b) The belt guard half does not rub against the reducer shaft.
 - c) The mounting holes in the support brackets are spaced out as far as possible. Do not locate the holes closer than 2 inches from the edge of the belt guard half.
 - d) The mounting holes in the support brackets are located as close as possible to the horizontal centerline of the belt guard half.
8. After the brackets and belt guard have been properly adjusted, use the pen or pencil to mark the location of the bracket mounting holes on the back of the belt guard half.
9. Put down the belt guard half and drill two 5/16" holes where the pen or pencil marks are located.
10. Lift the belt guard half back into position. Use two 1/4-20x1 bolts, two 1/4-20 nuts, and four 1/4" flat washers to mount the belt guard half to the support brackets. Tighten the bolted connection with the two 7/16" wrenches.

11. Verify the criteria listed in Step #7 is still correct. If it is, then continue with Step #12. If it is not, then adjust the assembly accordingly and recheck.
12. Use the 1 1/8" wrench to tighten the bolts in the motor mounting plate and threaded rod connections.
13. Install the correct belt drive.
14. Lift the remaining belt guard half into position. Use eight 1/4-20x1 bolts, eight 1/4-20 nuts, and sixteen 1/4" flat washers to attach the remaining belt guard half to the mounted belt guard half. Tighten the bolted connection with the two 7/16" wrenches.

Instructions for Mounting Torque Arms

1. For standard torque arm TA415-RBC/1. With reducer already on shaft in correct location. Thread the two threaded rods into turnbuckle and attach the assembly to reducer using 1 1/2 x 6" long capscrew, nut and lockwasher. Mount the torque arm fulcrum to a rigid support surface. Attach the torque arm rod to the fulcrum using 1 1/2 x 7" long capscrew, nut and lockwasher. Turn the turnbuckle to level the reducer using the level gage mounted on reducer. After reducer is leveled tighten all capscrews to proper torque. Verify that the horizontal and vertical mounting dimensions do not exceed the specifications provided on page 7. If the actual dimensions exceed the specifications, contact Browning before operating this unit.
2. For torque arm TA415-RBC/2. With reducer already mounted on shaft in correct position. Attach torque arm to reducer using 1 1/2 x 6" long capscrew and nut. (Torque arm is solid one piece.) Mount the torque arm fulcrum to a rigid support surface. (Fulcrum must be fully supported over entire mounting surface.) Attach torque arm and spacer to the fulcrum using 1 1/2 x 8 1/2" long capscrew, nut and lockwasher. Spacer can be mounted on either side of the torque arm to match fulcrum mounting position. Tighten the capscrews and nuts to 176-265 FT. LBS.
3. For torque arm TA415-RBC/3. With reducer already mounted on shaft in correct location. Attach torque arm to reducer using 1 1/2 x 6" long capscrew, nut and lockwasher. (Torque arm is solid one piece.) Mount torque arm fulcrum to a rigid support surface. Attach torque arm to the fulcrum using 1 1/2 x 7" long capscrew, nut and lockwasher. Since this torque arm mounts the reducer at an angle the oil level sight glass and breather will need to be repositioned. See diagram for instructions. Tighten the capscrews and nuts to 176-265 FT. LBS.



Disconnect all power while adjusting units

Torque Arm Kit Options

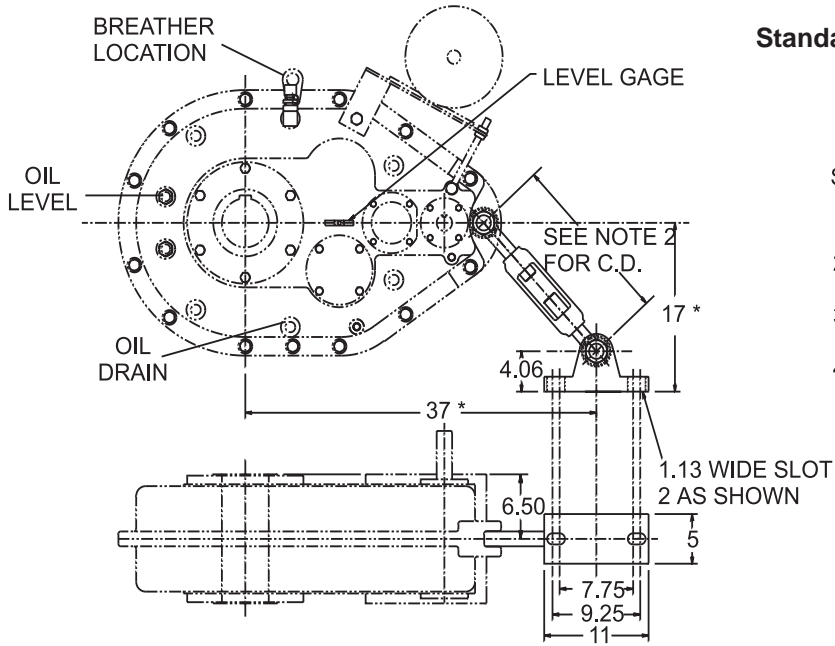

Standard Torque Arm Kit TA415-RBC/1

SPECIFICATIONS

- 1) TORQUE ARM AND TURNBUCKLE ARE PAINTED BROWNING STD GRAY.
- 2) MOUNTING DIMENSION IS ADJUSTABLE FROM 14.75 TO 20.75 IN.
- 3) ADJUST TORQUE ARM UNTIL UNIT IS LEVEL.
- 4) APPROXIMATELY 11 GALS. OF OIL.

* HORIZONTAL MOUNTING DIMENSION NOT TO BE MORE THAN 37", VERTICAL MOUNTING DIMENSION NOT TO BE LESS THAN 17".

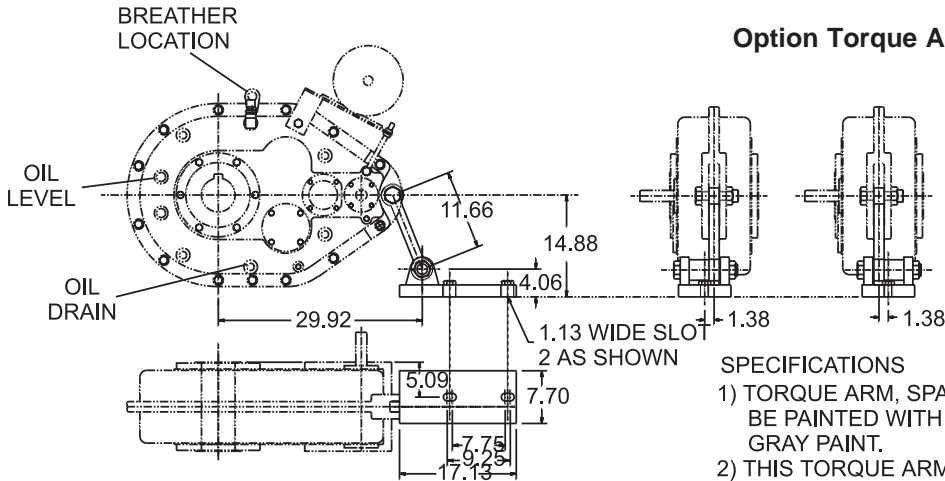

Option Torque Arm Kit TA415-RBC/2

SPECIFICATIONS

- 1) TORQUE ARM, SPACER AND BRACKET TO BE PAINTED WITH BROWNING STANDARD GRAY PAINT.
- 2) THIS TORQUE ARM IS USED FOR A WINSMITH REPLACEMENT.
- 3) APPROXIMATELY 11 GALS. OF OIL.

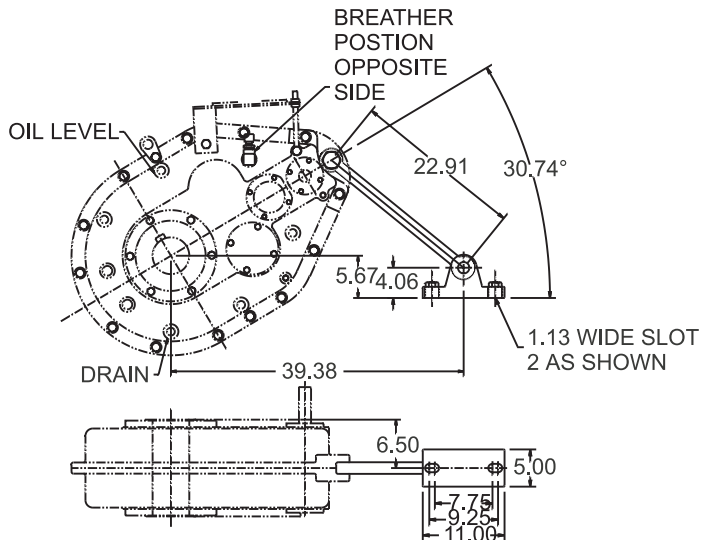

Option Torque Arm Kit TA415-RBC/3

SPECIFICATIONS

- 1) TORQUE ARM AND BRACKET TO BE PAINTED WITH BROWNING STANDARD GRAY PAINT.
- 2) THIS TORQUE ARM USED AS A DODGE REPLACEMENT.
- 3) NAMEPLATE DATA FOR OIL CAPACITY SHOULD BE 15.5 GALS. WHEN USING THIS TORQUE ARM.



WARNING Disconnect all power while adjusting units

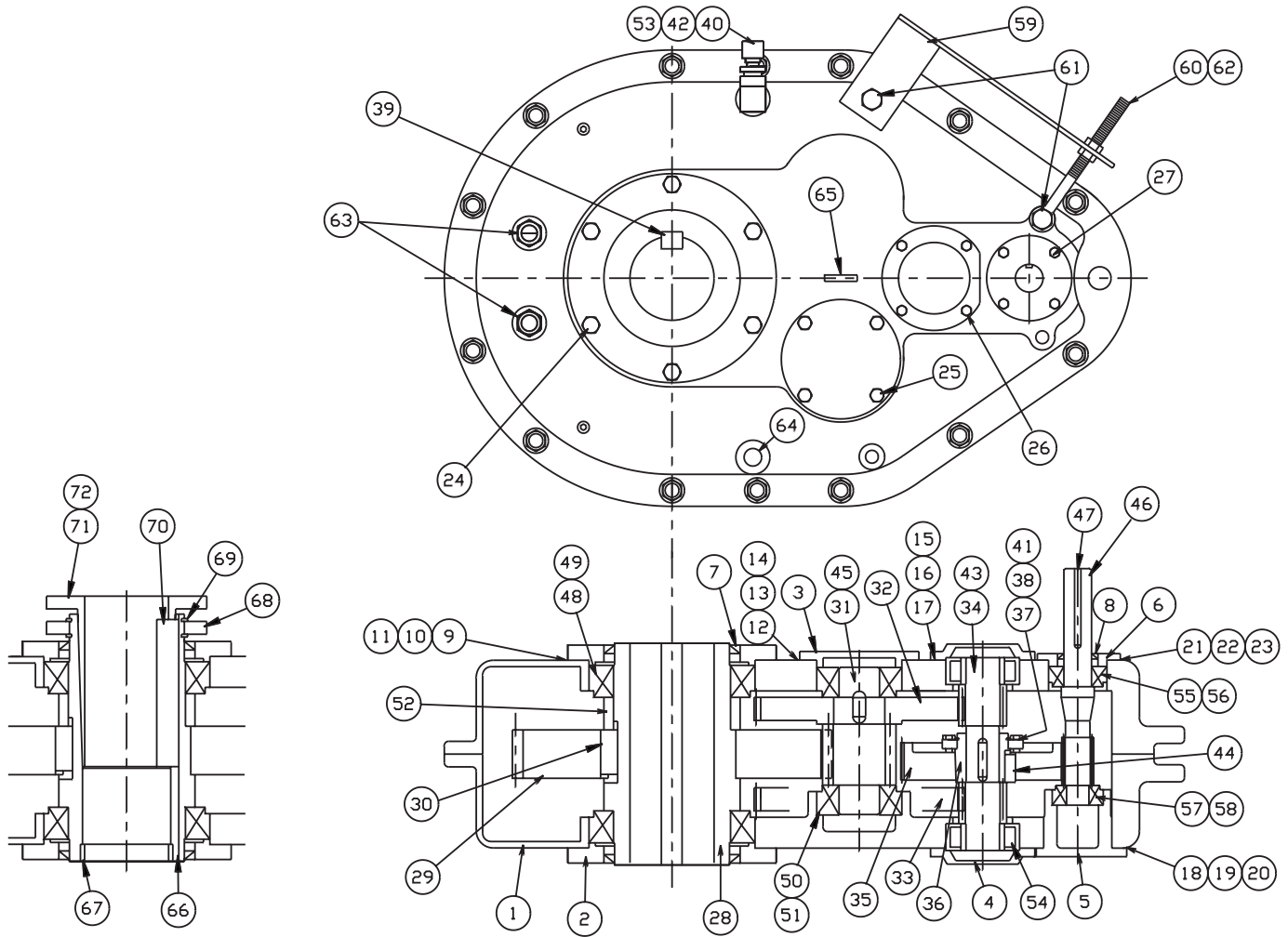

WARNING

Disconnect all power while adjusting units

ITEM NO.		ITEM	QTY.	PART NO.	DWG. NO.
SMF	SMT				
1	1	HOUSING	1	LY5001-5 MACH HSG	LY-5001-5
2	2	LSG COVER	2	LY5001-40 COVER	LY-5001-40
3	3	LSP COVER	2	B3222130 7.00 OD COV	B3222130
4	4	INT PIN COVER	2	LY5001-21 COVER	LY-5001-21
5	5	HSP COVER-C	1	LY5001-12 COVER	LY-5001-12
6	6	HSP COVER-O	1	LY5001-14 COVER	LY-5001-14
7	7	OUTPUT SEAL	2	A3222551 SEAL 6.75 ID	A3222551
8	8	INPUT SEAL	1	A3217817 SEAL 1.63 ID	A3217817
9	9	OUTPUT SHIM	1	12.25 OD 002THK SHIM	A3222478
10	10	OUTPUT SHIM	1	12.25 OD 005THK SHIM	A3222486
11	11	OUTPUT SHIM	3	12.25 OD 010THK SHIM	A3222494
12	12	INT SHIM	1	7.00 OD 002THK SHIM	A3222445
13	13	INT SHIM	1	7.00 OD 005THK SHIM	A3222452
14	14	INT SHIM	3	7.00 OD 010THK SHIM	A3222460
15	15	INT SHIM	1	LY5001-28 SHIM .002	LY-5001-28
16	16	INT SHIM	1	LY5001-28 SHIM .005	LY-5001-28
17	17	INT SHIM	3	LY5001-28 SHIM .010	LY-5001-28
18	18	INPUT SHIM	1	LY5001-25 SHIM .002	LY-5001-25
19	19	INPUT SHIM	1	LY5001-25 SHIM .002	LY-5001-25
20	20	INPUT SHIM	3	LY5001-22 SHIM .002	LY-5001-25
21	21	INPUT SHIM	1	LY5001-22 SHIM .002	LY-5001-22
22	22	INPUT SHIM	1	LY5001-22 SHIM .005	LY-5001-22
23	23	INPUT SHIM	3	LY5001-22 SHIM .010	LY-5001-22
24	24	CAPSCREWS	12	5/8-11X2 HXHD CS	A4060836
25	25	CAPSCREWS	8	1/2-13X 1 1/4 HXHD CS	A4060661
26	26	CAPSCREWS	8	3/8-16X 1 1/4 HXHD CS	A4060489
27	27	CAPSCREWS	8	7/16-14X 1 1/4 HXHD CS	A4060588
28	-	QUILL (FINISH BORE)	1	LY5001-7 QUILL	LY-5001-7
29	29	LS GEAR	1	B3222049 3.75-61 GEAR	B3222049
30	30	LSG KEY	1	A3222080 KR298 KEY	A3222080
31	31	1ST INT PIN	2	B3222023 3.75-12 PIN	B3222023
32	32	1ST INT GEAR	1	B3222056 6-61 GEAR	B3222056
33	33	1ST INT GEAR	1	LY5001-6 GEAR	LY-5001-6
34	34	2ND INT PIN	1	LY5001-8 PINION	LY-5001-8
35	35	HS GEAR	1	LY5001-9 SPUR GEAR	LY-5001-9
36	36	BUSHING	1	LY5001-18 BUSHING	LY-5001-18
37	37	BUSHING RING	1	LY5001-19 RING	LY-5001-19
38	38	CAPSCREWS	4	3/8-16X1 1/2 SPCL	
39	-	OUTPUT KEY (FINISH BORE)	1	LY5001-23 KEY	LY-5001-23
40	40	BREATHER	1	A4067682 BA.375 MICRO	A4067682
41	41	SNAP RING	1	A4065173 RING 2.7 ID	A4065173
42	42	PIPE REDUCER	1	A4064689 3/4 - 3/8	A4064689
43	43	KEY (HS PINION)	1	A40932178AKEY022	A4093217
44	44	KEY (HS GEAR)	1	LY5001-24 KEY	LY-5001-24
45	45	KEY	2	A3222072 KR297 KEY	A3222072
46	46	HS PINION	1	LY5001-10 SPUR PINION	LY-5001-10
47	47	KEY	1	KR306 KEY	A3218252
48	48	OUTPUT BRG.	2	A4048815 CUP 9.7 OD	A4048815
49	49	OUTPUT BRG.	2	A3222569 CONE 6.875 ID	A3222569
50	50	1ST INT BRGS.	4	A3222577 CUP 5.000 OD	A3222477
51	51	1ST INT BRGS.	4	A3222593 CONE 2.38 ID	A3222593
52	52	LS GEAR SPACER	1	LY5001-35 LS SPACER	LY-5001-35
53	53	STREET ELBOW	1	A4070678 3/4-90 ST L	A4070678
54	54	2ND INT BRGS.	2	A3510963 NU2310	A3510963
55	55	INPUT BRGS.	1	A3218393 CUP 3.438 OD	A3218393
56	56	INPUT BRGS.	1	A3218641 CONE 1.63 ID	A3218641
57	57	INPUT BRGS.	1	A4049029 CUP 3.0 OD	A4049029
58	58	INPUT BRGS.	1	A4094629 CONE 1.31 ID	A4094629
59	59	SWING BASE MTR MT	1	LY5001-17 SB MTR MT	LY-5001-17
60	60	EYE BOLT ROD	2	LY5001-15 EYE BLT ROD	LY-5001-15
61	61	CAPSCREW	4	3/4-10X 1 3/4 HXHD CS	A4060901
62	62	HEX NUTS	4	5/8-11 HEX NUT	A4062618
63	63	SIGHT GAGE	2	A3241825 1265 SHTGAGE	A3241825
64	64	DRAIN PLUG	1	A4061891 MAG PLG	A4061891
65	65	LEVEL	1	A3531977 LEVEL	A3531977
-	66	QUILL (BUSHED BORE)	1	C1725076 QUILL	C1726076
-	67	RING	2	A1725084 RING	A1725084
-	68	BUSHING RING	1	B3222279 415BUSH RING	B3222239
-	69	SNAP RING	2	A3222254 6.75 ID RING	A3222254
-	70	KEY	1	KR299 KEY	A3222361
-	71	BUSHING	1	B1725092 415TB415	B1725092
-	72	CAPSCREWS	4	5/8-11X2 HXHD CS	A4060836



WARNING Disconnect all power while adjusting units

