

Tech Bulletin

4000 Constant Tension Requirements

The following parts should be removed from the reel to make it constant tension.

Item #	Part #	Qty.	Description
7	400019	1	Latch Cam
20	400021	1	Latch Plate Bumper
21	S32-136	1	Self Tapping Screw
22	400012	1	Latch Bushing
23	400018	1	Latch Plate Spring
26	400109	1	Latch Plate Assembly

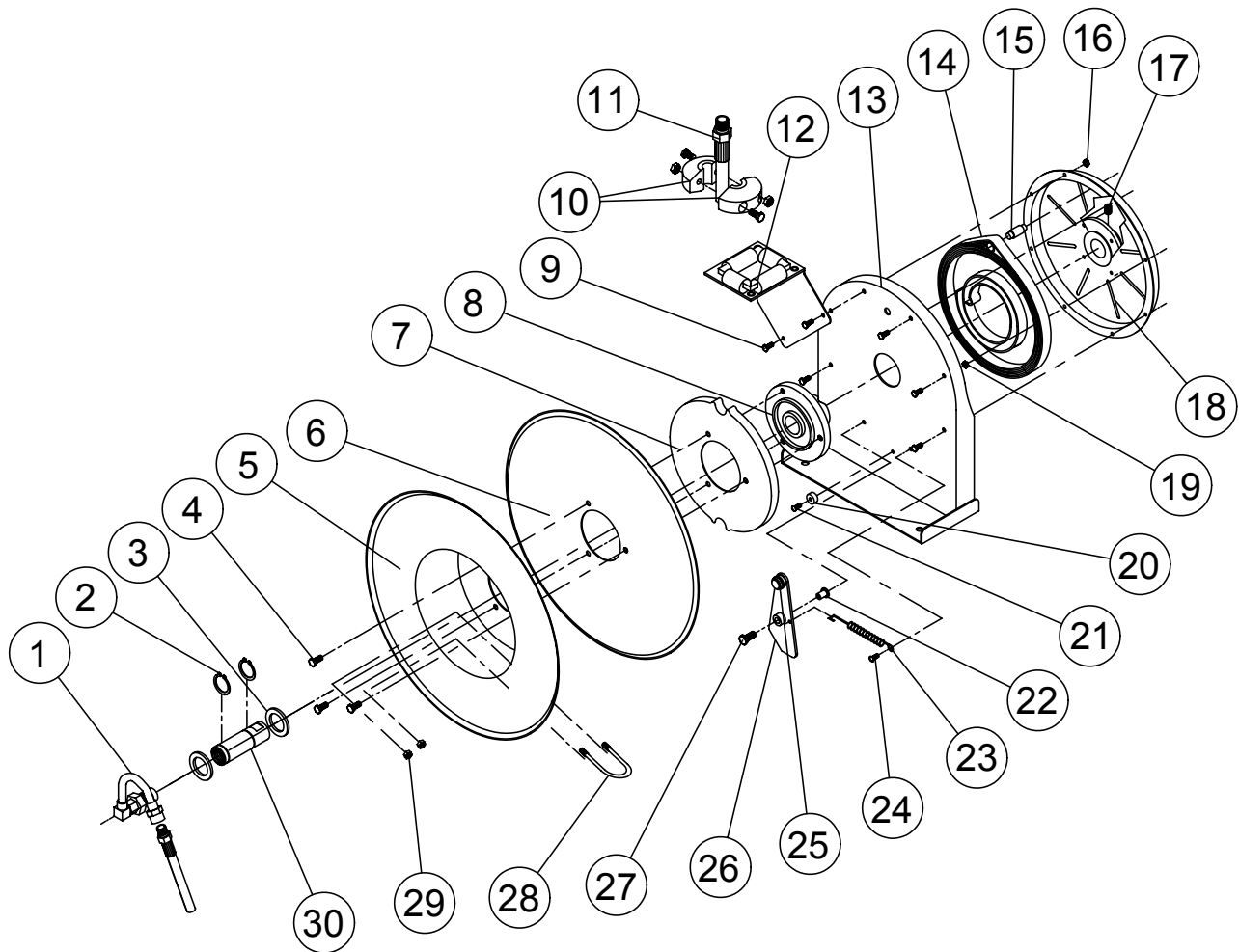

Form # TB0003 Rev: 5/2012

4000 Constant Tension Requirements

Item #	Part #	# Req.	Description	Item #	Part #	# Req.	Description
1	600886	1	Swivel Assembly	18	400103	1	Spring Case Assembly
2	300031	2	1" Snap Ring	19	S82-15	1	10-32 x 3/8" Nyloc Nut
3	300034	2	Spacing Washer	20	400021	1	Latch Bumper
4	S295-102	3	1/4" Plastite Hex Screw	21	S32-136	1	10-24 x 3/8" Mach. Screw
5	400005	1	Flange Assembly	22	400012	1	Latch Bushing
6	400006	1	Sheave Disk	23	400018	1	Latch Spring
7	400019	1	Latch Cam	24	300001	5	10-32 x 3/8" Screw
8	260648	1	Spring Arbor	25	400020	1	O-ring
9	300002	2	10-32 x 1/2" Screw	26	400109	1	Latch Plate Assembly
12	400107	1	Guide Arm Assembly	27	300035	1	10-32 x 1" Mach. Screw
13	400101	1	Base Assembly	28	3-117440	1	U-bolt
15	261360	1	Spring Case Stud	29	261650-1	2	1/4-20 Zinc Nyloc Nut
16	300011	7	10-32 Hex Lock Nut	30	400015	1	Main Shaft
17	300006	1	3/8-16 x 1/2" Set Screw				

Item #	Description	# Req.	4400 OLP	4420 OLP	4425 OLP	4430 OLP	4435 OLP
10	Hose Bumper Assembly	1	None	A1-HR1004A	A1-HR1004A	A1-HR1004A	A1-HR1004A
11	Hose Assembly	1	None	601001-20	601001-25	601000-30	601001-35
14	Drive Spring Assembly	1	400030	400030	400030	400030	400030
Hose I.D. and Length			None	1/4" x 20'	1/4" x 25'	1/4" x 30'	1/4" x 35'
Reel Inlet Connection			3/8" F.P.T.	3/8" F.P.T.	3/8" F.P.T.	3/8" F.P.T.	3/8" F.P.T.
Max. Operating Pressure			500 P.S.I.	300 P.S.I.	300 P.S.I.	300 P.S.I.	300 P.S.I.
Max. Operating Temperature			210° F	150° F	150° F	150° F	150° F

Item #	Description	# Req.	4600 OLP	4615 OLP	4617 OLP	4620 OLP	4625 OLP
10	Hose Bumper Assembly	1	None	A1-HR1004	A1-HR1004	A1-HR1004	A1-HR1004
11	Hose Assembly	1	None	601011-15	601011-17	601011-20	601013-25
14	Drive Spring Assembly	1	404230	404230	404230	404230	404230
Hose I.D. and Length			None	3/8" x 15'	3/8" x 17'	3/8" x 20'	3/8" x 25'
Reel Inlet Connection			3/8" F.P.T.	3/8" F.P.T.	3/8" F.P.T.	3/8" F.P.T.	3/8" F.P.T.
Max. Operating Pressure			500 P.S.I.	300 P.S.I.	300 P.S.I.	300 P.S.I.	300 P.S.I.
Max. Operating Temperature			210° F	150° F	150° F	150° F	150° F