

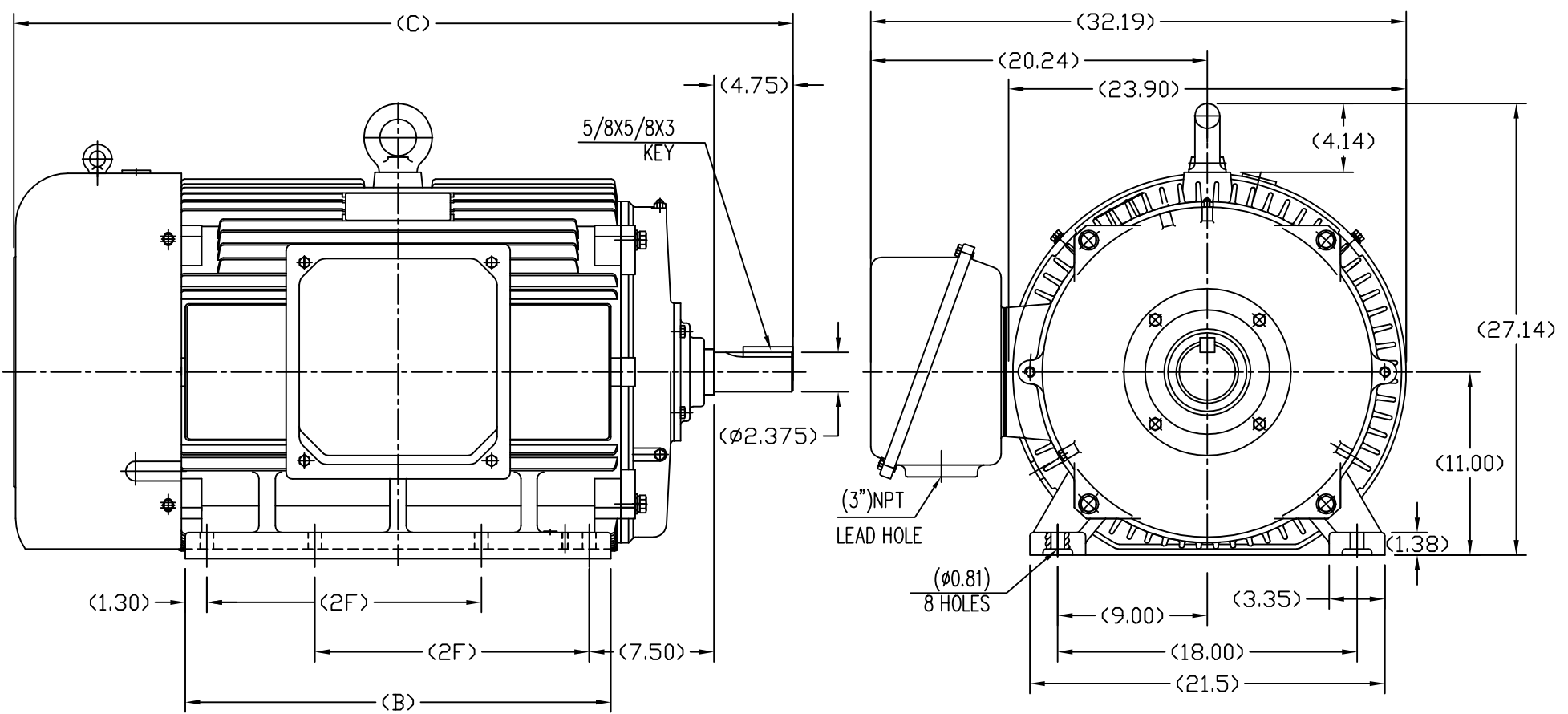

SS620281



444TS	47.05	25.60	14.50
445TS			16.50
447TS	52.17	30.70	20.00
449TS			25.00
Frame	C	BB	2F

		TOLERANCES UNLESS SPECIFIED		 REGAL-BELOIT CORPORATION		DRAWN ZYH 02-21-2010	
		DEC.	INCHES			CHK HZJ 02-21-2010	
		.X	±.1	TITLE		SCALE 1=6	
		.XX	±.03	444/445/447/449TS FR-TEFC CAST IRON		REF	
A		.XXX	±.005	MAT'L.		FMF HWADA	
NO.		.XXXX	±.0005	FINISH		PREV	
REVISION		BY & DATE	CHK ANG ±1/2	CAD FILE		SIZE DRAWING NO.	
2 leads hole change to 1		CL 2010-9-8		SS620281		B SS620281	
THIS DRAWING IN DESIGN AND DETAIL IS OUR PROPERTY AND MUST NOT BE USED EXCEPT IN CONNECTION WITH OUR WORK. ALL RIGHTS OF DESIGN AND INVENTION ARE RESERVED. THIS IS AN ELECTRONICALLY GENERATED DOCUMENT - DO NOT SCALE THIS PRINT.				DIST		REV.	