

H-MOSS® Controls

Adaptive Dual Technology

Wall Switches Features

- Neutral required
- Dual technology sensing combines the individual advantages of passive infrared and ultrasonic detection
- Built in photocell with manual super saver mode for daylight harvesting
- Impact resistant hard lens is standard and color matched to the switch

HUBBELL



Ordering Information

Description	Device Color	UPC Number	Catalog Number
Dual (ultrasonic and passive infrared), 1 button for auto/manual control	Ivory	783585413372	ADN2000I1N

Listings

cULus Listed
Meets ASHRAE 90.1
CEC Title 24 Certified

Specifications

Housing	High impact plastic (UL-94-5V)
Mounting Strap	Plated steel
Lens	Dual element pyrometer and 12 element cylindrical hard lens
Sensing Indicator	Passive Infrared, Red LED. Ultrasonic, Green LED.

Performance

Electrical	
Load Capacity	Incandescent - 0 to 800 watts, 120V AC Ballast - 0 to 1000 watts, 277V AC Ballast 0 to 1800 watts
Power Supply	120/277V AC, 50/60Hz
Mechanical	
Wire Leads	#18 AWG stranded wire, 6" long with 1/2" stripped ends
Environmental	
Operating Temperature	32°F to 104°F (0°C to 40°C); 0% to 95% non-condensing relative humidity
Controls	
Ambient Light	Adjustable ambient light override, 10 to 500 foot candles
Sensitivity	Adaptive 0% to 100%
Time Delay	Digital, adaptive 4 to 30 minutes
Coverage Pattern	
Area	1000 square foot. Area of coverage based on passive infrared technology minor motion pattern. See illustration.
Mounting Height	42 to 54 inches above floor

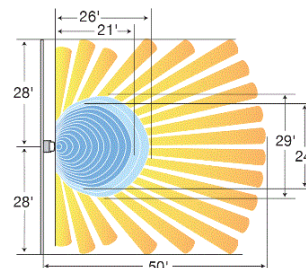
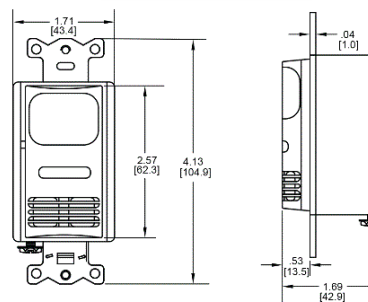

Accessories

Wallplate **NP26I, SS26, RCW1I**

Online Resources

[eCatalog](#)

Dimensions in Inches (mm)

Hubbell Wiring Device-Kellems • Hubbell Incorporated (Delaware) • 40 Waterview Drive • Shelton, CT 06484

Phone (800) 288-6000 • Fax (800) 255-1031 • Specifications subject to change without notice.

