

CM, CME

Service instructions

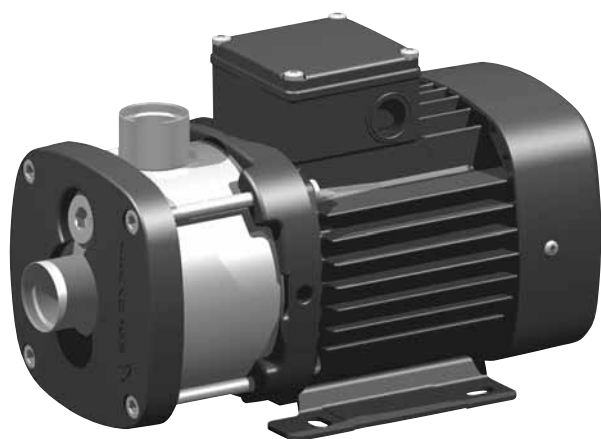

Original service instructions.

CONTENTS

	Page
1. Symbols used in this document	3
2. Type identification	4
2.1 Nameplate	4
2.2 Type key	5
3. Tightening torques and lubricants	6
4. Service tools	7
4.1 Standard tools	7
4.2 Torque tools	7
5. Dismantling and assembly	8
5.1 General information	8
5.2 CM 1, 3, 5, cast iron	8
5.3 CM 1, 3, 5, stainless steel	9
5.4 CM 10, 15, 25, cast iron	10
5.5 CM 10, 15, 25, stainless steel	12
5.6 MG 71 and MG 80 motors	13
5.7 MG 90, MG 100, MG 112 and MG 132 motors	13
5.8 Checking and replacing impellers and chambers	14
6. Fault finding	15
7. Drawings	16
7.1 CM 1, 3, 5	16
7.2 CM 10, 15, 25	18
8. Order of assembly for chambers and impellers	20
8.1 Key for CM 1, 3, 5	20
8.2 CM 1, 3, 5, cast iron	20
8.3 CM 1, 3, 5, stainless steel	20
8.4 Key for CM 10, 15, 25	21
8.5 CM 10, 15, 25, cast iron	21
8.6 CM 10, 15, 25, stainless steel	22

1. Symbols used in this document



Warning

If these safety instructions are not observed, it may result in personal injury.

Caution

If these safety instructions are not observed, it may result in malfunction or damage to the equipment.

Note

Notes or instructions that make the job easier and ensure safe operation.

2. Type identification

This section shows the nameplate, the type key and the codes that can appear in the variant code.

Note As codes can be combined, a code position may contain more than one code (letter).

2.1 Nameplate

Type <input type="text"/>		P _{max} <input type="text"/> bar <input type="text"/> PSI <input type="text"/> MPa	
Model <input type="text"/>		T _{liq,max} <input type="text"/> °C <input type="text"/> °F	
Env <input type="text"/>	IP <input type="text"/>	T _{Amb} <input type="text"/> °C <input type="text"/> °F	Insulation class <input type="text"/> <input type="text"/>
50 Hz	Q _{nom} <input type="text"/> m ³ /h <input type="text"/> GPM	ZH 09	Q _{nom} <input type="text"/> m ³ /h <input type="text"/> GPM
	H _{nom} <input type="text"/> m <input type="text"/> PSI		H _{nom} <input type="text"/> m <input type="text"/> PSI
	H _{max} <input type="text"/> m <input type="text"/> PSI		H _{max} <input type="text"/> m <input type="text"/> PSI

Fig. 1 Pump nameplate

50 Hz	<input type="text"/> ~ <input type="text"/> / <input type="text"/> V	60 Hz	<input type="text"/> ~ <input type="text"/> / <input type="text"/> V
I _{max}	<input type="text"/> / <input type="text"/> A	I _{max}	<input type="text"/> / <input type="text"/> A
I _{1/1}	<input type="text"/> / <input type="text"/> A	I _{1/1}	<input type="text"/> / <input type="text"/> A
P ₂	<input type="text"/> kW <input type="text"/> HP	P ₂	<input type="text"/> kW <input type="text"/> HP
Capacitor	<input type="text"/> uF / V	Capacitor	<input type="text"/> uF / V

CE GRUNDFOS X

Fig. 2 Motor nameplate

The pump and motor nameplates are positioned on the motor fan cover or terminal box.

The data and information on the pump nameplate are described in the table below.

Pos.	Description
1	Pump type
2	Pump model
3	Environmental rating for enclosures based on NEMA type designations
4	Enclosure class
5	Maximum ambient temperature [°C] / [°F]
6	Maximum system pressure [bar] / [psi] / [MPa]
7	Maximum liquid temperature [°C] / [°F]
8	Insulation class
9	Motor protection
10	Rated flow [m ³ /h] / [GPM]
11	Head at rated flow [m] / [psi]
12	Maximum head [m] / [psi]

The data and information on the motor nameplate are described in the table below.

Pos.	Description
1	Number of phases
2	Voltage [V]
3	Maximum current [A]
4	Rated current [A]
5	Power output [kW] / [hp]
6	Single-phase pumps only: Capacitor size [µF] and voltage [V]

2.2 Type key

CM, CME

Example	CME	10	-	8	A	-	R	-	A	-	E	-	A	V	B	E	X	-	X	-	X	-	X
Type range																							Sensor
CM Centrifugal Modular																							Sensor designation
CME: CM with integrated frequency converter																							
Rated flow rate																							
Rated flow rate at 50 Hz [m ³ /h]																							
Number of impellers																							
Pump version																							
A:	Basic version																						
B:	Oversize motor (one flange size larger)																						
E:	Pumps with certificates and other approvals																						
HS:	High-pressure pump with high-speed MGE motor																						
I:	Altered pressure class																						
J:	Pump with a different maximum speed																						
M:	Magnet-driven pump																						
N:	CME pump with sensor (see code for "Sensor")																						
P:	Undersize motor (one flange size smaller)																						
T:	Oversize motor (two flange sizes larger)																						
V:	CME pump for Multi-E																						
X:	Special pump																						
Motor information																							
A:	Standard motor (IP55)																						
B:	Phase-insulated motor for use with frequency converter																						
C:	IP54																						
D:	Pt100 in stator																						
E:	Angular contact bearing																						
F:	Motor heater																						
G:	Three-phase motor with overload protection																						
H:	Single-phase motor with no overload protection																						
Supply voltage																							
A:	1 x 220 V, 60 Hz																						
B:	1 x 115/230 V, 60 Hz																						
C:	1 x 220-240 V, 50 Hz																						
D:	1 x 127 V, 60 Hz																						
E:	3 x 208-230/440-480 V, 60 Hz																						
F:	3 x 220-240/380-415 V, 50 Hz																						
G:	3 x 200/346 V, 50 Hz; 200-220/346-380 V, 60 Hz																						
H:	3 x 575 V, 60 Hz																						
I:	3 x 400 V, 50/60 Hz																						
J:	3 x 380-415 V, 50 Hz; 440-480 V, 60 Hz																						
K:	1 x 220-240 V, MGE motor																						
L:	3 x 380-480 V, MGE motor																						
M:	1 x 208-230 V, MLE motor																						
N:	3 x 460-480 V, MLE motor																						
O:	3 x 220-240/380-415 V, 50 Hz 3 x 220-255/380-440 V, 60 Hz																						
Material of secondary seal																							
E:	EPDM (ethylene propylene)																						
K:	FFKM (perfluor)																						
V:	FKM (fluor)																						
Material of stationary shaft seal part																							
B:	Carbon, synthetic resin-impregnated																						
Q:	Silicon carbide (SiC)																						
Material of rotating seal face																							
Q:	Silicon carbide (SiC)																						
V:	Aluminium oxide (Al ₂ O ₃)																						
Shaft seal type designation																							
A:	O-ring seal with fixed driver																						
Materials in contact with pumped liquid																							
	Inlet and discharge parts	EN-GJL-200																					
A:	Pump shaft	EN 1.4057/AISI 431																					
	Impellers/chambers	EN 1.4301/AISI 304																					
	Sleeve	EN 1.4401/AISI 316																					
G:	Pump shaft	EN 1.4401/AISI 316																					
	Impellers/chambers	EN 1.4401/AISI 316																					
	Sleeve	EN 1.4301/AISI 304																					
I:	Pump shaft	EN 1.4301/AISI 304																					
	Impellers/chambers	EN 1.4301/AISI 304																					
X:	Special version																						
Rubber parts in pump (excl. neck ring and shaft seal)																							
E:	EPDM (ethylene propylene)																						
K:	FFKM (perfluor)																						
V:	FKM (fluor)																						
Note:	Gaskets between chambers of cast-iron versions are made of Tesnit BA-U.																						

Note

The type key cannot be used for ordering, as not all combinations are possible.

3. Tightening torques and lubricants

Pos.	Designation	Quantity	Dimensions	Torque [Nm]	Lubricant
2b	Screw, CM 1, 3, 5	2	M8 x 40	16 - 18	THREAD-EZE
	Hexagon socket head cap screw CM 10, 15, 25	2	M8 x 80	16 - 18	THREAD-EZE
11	O-ring	2	Ø18.5 x 2.0	-	-
25	Plug	2	-	10 - 12	-
26	Staybolt, CM 1, 3, 5, cast iron	4	M6	12 - 14	-
	Staybolt, CM 1, 3, 5, stainless steel	4	M8	12 - 14	-
	Staybolt, CM 10, 15, 25, cast iron	4	M8	25-27	THREAD-EZE
	Staybolt, CM 10, 15, 25, stainless steel	4	M8	20-22	-
28g	Screw	4	M6 x 14	8 - 10	THREAD-EZE
31	O-ring, CM 1, 3, 5	1	Ø114.0 x 3.90	-	Rocol 22
	O-ring, CM 10, 15, 25	1	Ø153.2 x 4.70	-	Rocol 22
67	Lock nut	1	M8	16 - 18	-
102	O-ring	1	Ø17.86 x 2.62	-	V7140084
103	Seal faces	1	-	-	Silicone oil, 350 cSt, food grade
107	O-ring	1	Ø11.5 x 3.18	-	Rocol 22
152	Screw	2	M4 x 8	2.7 - 3.3	-
		4	M5 x 12	3.5 - 4	-
155	Bearing cover plate	1	-	-	Rocol 22
157a	Gasket, MG 71, MG 80	1	Ø114.8 / 121.2 x 0.25	-	-
	Gasket, MG 90	2	Ø141.2 / 145.5	-	-
	Gasket, MG 100	-	-	-	-
158a	O-ring	1	Ø35.4 x 1.97	-	Rocol 22
	O-ring, MG 71, MG 80	1	Ø32 x 2	-	-
159	O-ring, MG 90, MG 100	1	Ø52 x 3.0	-	Rocol 22
	O-ring, MG 112, 132	1	Ø62 x 3.0	-	-
159a	Seal ring	1	-	-	Castrol LMX grease
	Screw, MG 71, MG 80	4	M6 x 16	5 - 8	-
181	Staybolt, MG 90	4	M5 x 220	4.5 - 6	THREAD-EZE
	Staybolt, MG 90L	4	M5 x 260		
	Staybolt, MG 100	4	M5 x 270		
	Staybolt, MG 112	4	M6 x 288		

THREAD-EZE, part number 00SV9997 (0.5 l).

Rocol 22, part number 00RM2924 (1 kg).

Castrol LMX grease, part number 00RM4311.

Silicone oil, 350 cSt, food grade 00SV0862 (1 l).

4. Service tools

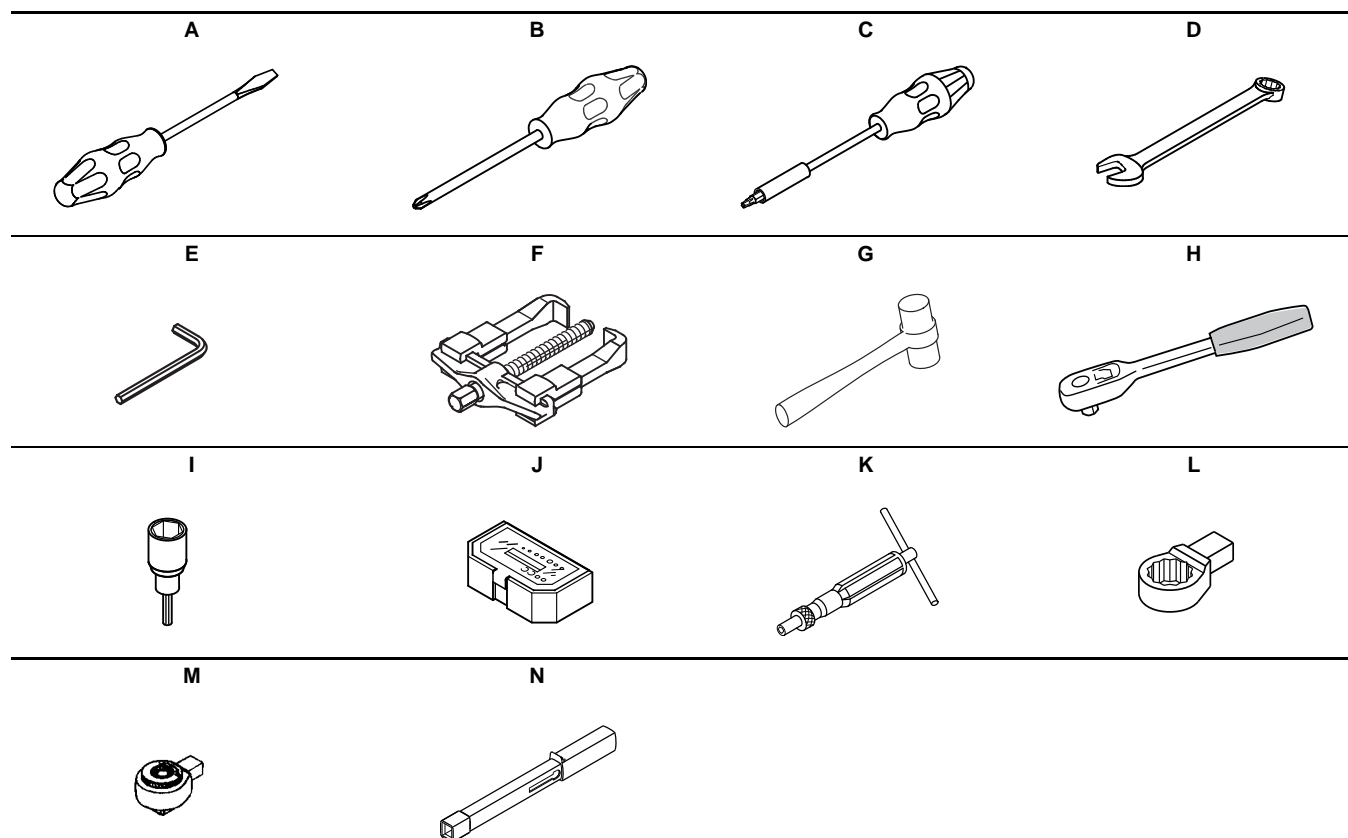

4.1 Standard tools

Pos.	Designation	For pos.	Further information	Part number
A	Screwdriver	103, 156	-	SV0803
B	Cross-head screwdriver	181	Ph2 x 100	SV0279
C	Torx screwdriver	J	TX30 x 115 mm	SV0335
D	Ring/open-end spanner	64c	15 mm	-
		67	13 mm	SV0055
E	Hexagon key	26	5 mm	-
			6 mm	SV0196
F	Puller for bearing	153, 154	-	-
G	Plastic hammer	156	-	SV0349
H	Ratchet handle	156	-	96777072
I	Hexagon head driver	26	M6 - 5 mm	SV0296
			M8 - 6 mm	SV0297
			M5 - 4 mm	-
J	Bits kit	28g, 152, 181	-	SV2010

4.2 Torque tools

Pos.	Designation	For pos.	Further information	Part number
K	Torque screwdriver	J	1-6 Nm	SV0438
L	Ring insert tool	N	13 mm - 9 x 12 mm	SV0294
M	Ratchet insert tool	I	9 x 12 mm - 1/2"	SV0295
N	Torque wrench	L, M	9 x 12 mm - 4-20 Nm	SV2092
			9 x 12 mm - 20-100 Nm	SV0269

5. Dismantling and assembly

5.1 General information

If it is necessary to dismantle the pump, either because it is choked or damaged, please follow the instructions in the following sections.

Position numbers of parts (digits) refer to section 7. *Drawings*; position numbers of tools (letters) refer to section 4. *Service tools*.

Before dismantling the pump

- Disconnect the electricity supply to the motor.
- Close the isolating valves, if fitted, to avoid draining the system.
- Remove the electric cable in accordance with local regulations.

Before assembly

- Clean and check all parts.
- Replace defective parts by new parts.
- Order the necessary service kits.
- Gaskets and O-rings should always be replaced when the pump is overhauled.

During assembly

- Lubricate and tighten screws and nuts to correct torque. See section 3. *Tightening torques and lubricants*.

5.2 CM 1, 3, 5, cast iron

5.2.1 Dismantling

1. Remove staybolts (pos. 26).
2. Remove inlet part (pos. 6).
3. Remove gasket (pos. 139b) and chamber (pos. 4e).
4. Hold clamp (pos. 64c), and remove nut (pos. 67).
5. Remove lock washers (pos. 66) and clamp (pos. 64c).
6. Remove impeller (pos. 49).
7. Remove bearing ring (pos. 47a) and short spacing pipe (pos. 64a).

Note *Step 7 applies only to pumps with eight stages.*

8. Remove chamber for bearing (pos. 4a), gasket (pos. 139b), impeller (pos. 49) and spacing pipe (pos. 64).

Note *Step 8 applies only to pumps with eight stages.*

9. Continue the dismantling until shaft seal (pos. 105).
10. Remove shaft seal (pos. 105). See fig. 3.

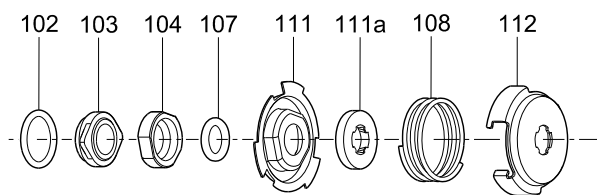

Fig. 3 Exploded view of shaft seal

Dismantling of MG 71 and MG 80, see section 5.6.1.

Note

Dismantling of MG 90 and MG 100, see section 5.7.1.

Note

It is advisable always to replace wear rings (pos. 45) and wear ring retainers (pos. 65). See section 5.8.

5.2.2 Assembly

Note *Assembly of MG 71 and MG 80, see section 5.6.2.*
Assembly of MG 90 and MG 100, see section 5.7.2.

1. Fit O-ring (pos. 102) on the stationary shaft seal part. See fig. 4. For correct lubricant, see section 3. *Tightening torques and lubricants*.

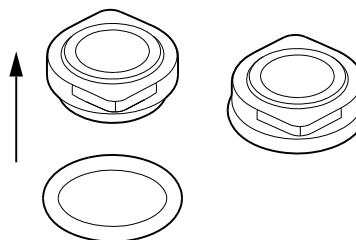

Fig. 4 Fitting the O-ring on the stationary shaft seal part

2. Press the stationary shaft seal part home. See fig. 5.



Warning

Do not touch the seal face.

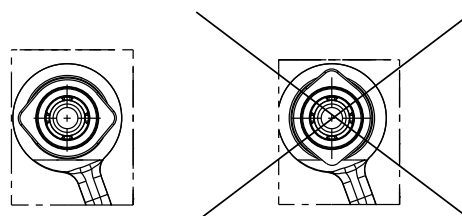

Fig. 5 Fitting the stationary shaft seal part (only SiC/SiC)

3. Fit the rotating shaft seal part (pos. 104) so that the seal face touches the stationary part.



Warning

Do not touch the seal face.

4. Fit O-ring (pos. 107) into the rotating shaft seal part (pos. 104). For correct lubricant, see section 3. *Tightening torques and lubricants*.
5. Fit retainer (pos. 111) and stop ring (pos. 111a). See fig. 6.

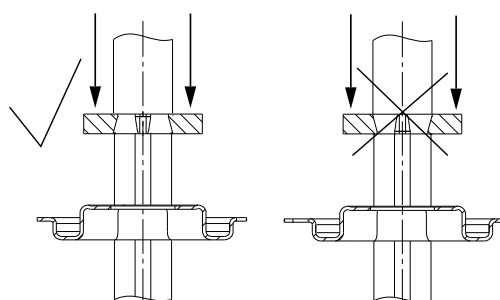

Fig. 6 Fitting the stop ring

6. Fit spring (pos. 108) and driver (pos. 112). See fig. 7.

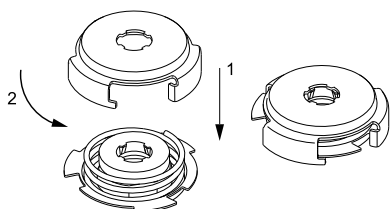

Fig. 7 Fitting the spring and driver

7. Fit impeller (pos. 49), spacing pipe (pos. 64), gasket (pos. 139b) and chamber plate (pos. 4f).
 8. Continue the assembly until chamber for bearing (pos. 4a).

Note Step 8 applies only to pumps with eight stages.

9. Fit chamber for bearing (pos. 4a), short spacing pipe (pos. 64a), gasket (pos. 139b) and bearing ring (pos. 47a). See section 8. Order of assembly for chambers and impellers.

Note Step 9 applies only to pumps with eight stages.

10. Fit impeller (pos. 49), clamp (pos. 64c), washers (pos. 66) and nut (pos. 67). See fig. 8.

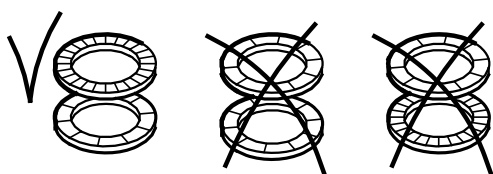

Fig. 8 Correct fitting of washers

11. Hold clamp (pos. 64c), and tighten nut (pos. 67). See section 3. Tightening torques and lubricants.
 12. Fit chamber (pos. 4e) and gasket (pos. 139b).
 13. Fit inlet part (pos. 6).
 14. Fit and cross-tighten staybolts (pos. 26). See section 3. Tightening torques and lubricants.

5.3 CM 1, 3, 5, stainless steel

5.3.1 Dismantling

1. Remove staybolts (pos. 26).
 2. Remove clamping flange (pos. 6a) and sleeve (pos. 16).
 3. Remove chamber (pos. 4e).
 4. Hold clamp (pos. 64c), and remove nut (pos. 67).
 5. Remove lock washers (pos. 66) and clamp (pos. 64c).
 6. Remove impeller (pos. 49).
 7. Remove bearing ring (pos. 47a) and short spacing pipe (pos. 64a).

Note Step 7 applies only to pumps with eight or more stages.

8. Remove chamber for bearing (pos. 4a), impeller (pos. 49) and spacing pipe (pos. 64).

Note Step 8 applies only to pumps with eight or more stages.

9. Continue the dismantling until shaft seal (pos. 105).
 10. Remove shaft seal (pos. 105). See fig. 9.

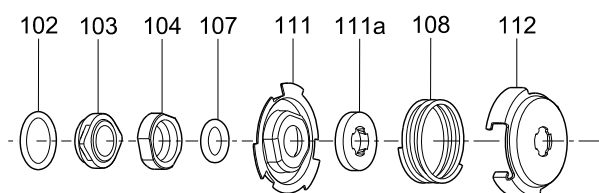

Fig. 9 Exploded view of shaft seal

11. Remove O-ring (pos. 31) and cover plate (pos. 32).

Note Dismantling of MG 71 and MG 80, see section 5.6.1.
 Dismantling of MG 90 and MG 100, see section 5.7.1.

Note It is advisable always to replace wear rings (pos. 45) and wear ring retainers (pos. 65). See section 5.8.

5.3.2 Assembly

Note Assembly of MG 71 and MG 80, see section 5.6.2.
 Assembly of MG 90 and MG 100, see section 5.7.2.

1. Fit cover plate (pos. 32) and O-ring (pos. 31). Lubricate the O-ring. See section 3. Tightening torques and lubricants.
 2. Fit O-ring (pos. 102) on the stationary shaft seal part. See fig. 10. See section 3. Tightening torques and lubricants.

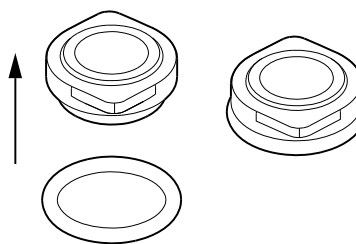

Fig. 10 Fitting the O-ring on the stationary shaft seal part

TM04 4326 1209

TM02 1057 0501

TM04 4322 1909

TM04 4327 1909

3. Press the stationary shaft seal part home. See fig. 11.



Warning
Do not touch the seal face.

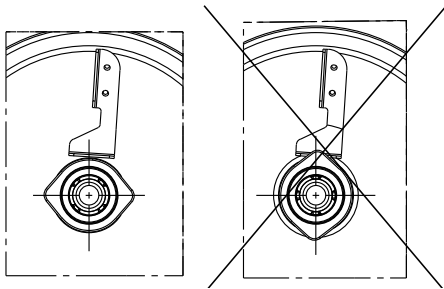

Fig. 11 Fitting the stationary shaft seal part (only SiC/SiC)

4. Fit the rotating shaft seal part (pos. 104) so that the seal face touches the stationary part.



Warning
Do not touch the seal face.

5. Fit O-ring (pos. 107) into the rotating shaft seal part (pos. 104). See section 3. *Tightening torques and lubricants.*
6. Fit retainer (pos. 111) and stop ring (pos. 111a). See fig. 12.

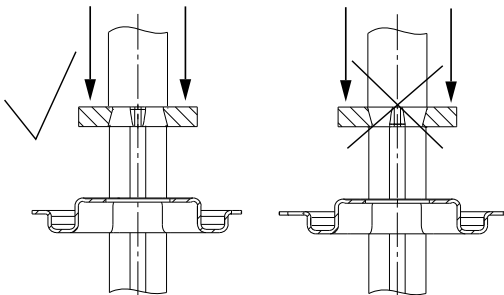

Fig. 12 Fitting the stop ring

7. Fit spring (pos. 108) and driver (pos. 112). See fig. 13.

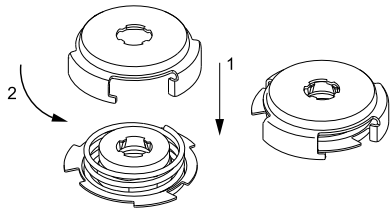

Fig. 13 Fitting the spring and driver

8. Fit impeller (pos. 49), chamber with holes (pos. 4d) and spacing pipe (pos. 64).
9. Fit impeller (pos. 49), chamber (pos. 4) and spacing pipe (pos. 64).
10. Fit impeller (pos. 49), chamber (pos. 4a), short spacing pipe (pos. 64a) and bearing ring (pos. 47a). See section 8. *Order of assembly for chambers and impellers.*

Note Step 10 applies only to pumps with eight or more stages.

11. Fit impeller (pos. 49), clamp (pos. 64c), washers (pos. 66) and nut (pos. 67). See fig. 14.

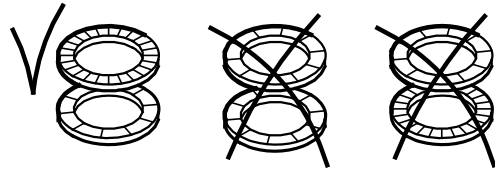

Fig. 14 Correct fitting of washers

12. Hold clamp (pos. 64c), and tighten nut (pos. 67). See section 3. *Tightening torques and lubricants.*
13. Fit chamber (pos. 4e), sleeve (pos. 16) and clamping flange (pos. 6a).

Caution Do not forget to fit the last chamber (pos. 4e), as it is possible to assemble the pump without the last chamber.

14. Fit and cross-tighten staybolts (pos. 26). See section 3. *Tightening torques and lubricants.*

5.4 CM 10, 15, 25, cast iron

5.4.1 Dismantling

1. Remove staybolts (pos. 26).
2. Remove inlet part (pos. 6) and gasket (pos. 139b).
3. Hold clamp (pos. 64c), and remove nut (pos. 67).
4. Remove lock washers (pos. 66) and clamp (pos. 64c).
5. Remove impeller (pos. 49) and spacing pipe (pos. 64).
6. Remove chamber (pos. 4).
7. Continue the dismantling until shaft seal (pos. 105).
8. Remove shaft seal (pos. 105). See fig. 15.

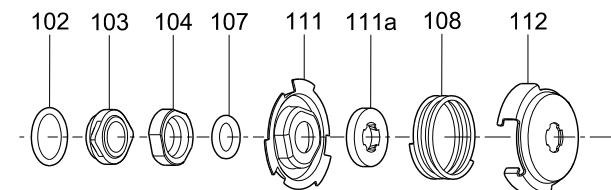

Fig. 15 Exploded view of shaft seal

9. Loosen and remove screws (pos. 2b) and discharge part (pos. 2).

Note Dismantling of MG 71 and MG 80, see section 5.6.1.
Dismantling of MG 90, MG 100, MG 112 and MG 132, see section 5.7.1.

Note It is advisable always to replace wear rings (pos. 45) and wear ring retainers (pos. 65). See section 5.8.

5.4.2 Assembly

Assembly of MG 71 and MG 80, see section 5.6.2.

Note **Assembly of MG 90, MG 100, MG 112 and MG 132, see section 5.7.2.**

1. Fit discharge part (pos. 2).
2. Fit and tighten screws (pos. 2b).
See section 3. *Tightening torques and lubricants*
3. Fit O-ring (pos. 102) on the stationary shaft seal part.
See fig. 16. See section 3. *Tightening torques and lubricants*.

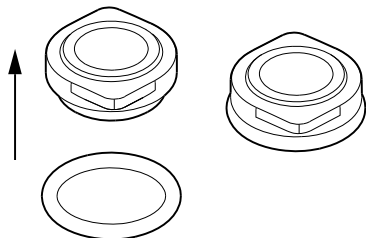

Fig. 16 Fitting the O-ring on the stationary shaft seal part

4. Press the stationary shaft seal part home. See fig. 17.



Warning
Do not touch the seal face.

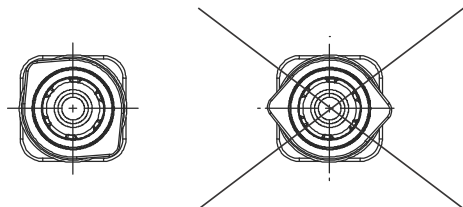

Fig. 17 Fitting the stationary shaft seal part (only SiC/SiC)

5. Fit the rotating shaft seal part (pos. 104) so that the seal face touches the stationary part.



Warning
Do not touch the seal face.

6. Fit O-ring (pos. 107) into the rotating shaft seal part (pos. 104).
See section 3. *Tightening torques and lubricants*
7. Fit retainer (pos. 111) and stop ring (pos. 111a). See fig. 18.

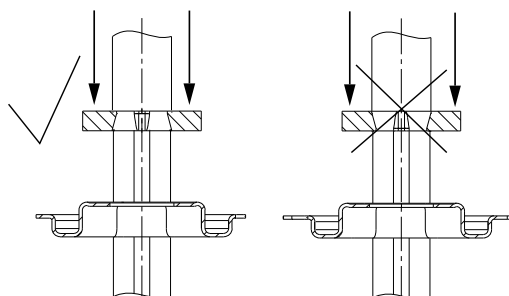

Fig. 18 Fitting the stop ring

8. Fit spring (pos. 108) and driver (pos. 112). See fig. 19.

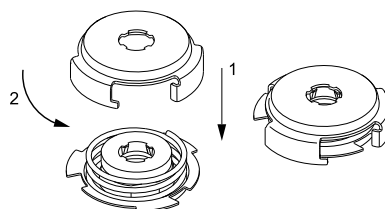

Fig. 19 Fitting the spring and driver

9. Fit short spacing pipe (pos. 64a), impeller (pos. 49), gasket (pos. 139c) and chamber (pos. 4g).
10. Fit gasket (pos. 139b), spacing pipe (pos. 64), impeller (pos. 49) and chamber (pos. 4).
11. Continue the assembly until clamp (pos. 64c). For correct fitting of chambers and impellers, see section 8. *Order of assembly for chambers and impellers*.
12. Fit impeller (pos. 49), clamp (pos. 64c), washers (pos. 66) and nut (pos. 67). See fig. 20.

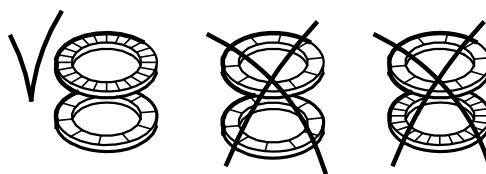

Fig. 20 Correct fitting of washers

13. Hold clamp (pos. 64c), and tighten nut (pos. 67).
See section 3. *Tightening torques and lubricants*.
14. Fit gasket (pos. 139b).
15. Fit inlet part (pos. 6).
16. Fit and cross-tighten staybolts (pos. 26).
See section 3. *Tightening torques and lubricants*.

TM04 4326 1209

TM04 4322 1209

TM02 1057 0501

TM04 5051 2509

TM04 4325 1209

5.5 CM 10, 15, 25, stainless steel

5.5.1 Dismantling

1. Remove staybolts (pos. 26).
2. Remove clamping flange (pos. 6a) and sleeve (pos. 16).
3. Remove the chamber plate (pos. 4f).
4. Hold clamp (pos. 64c), and remove nut (pos. 67).
5. Remove lock washers (pos. 66) and clamp (pos. 64c).
6. Remove impeller (pos. 49).
7. Remove spacing pipe (pos. 64e), bearing ring (pos. 47a) and chamber for bearing (pos. 4a).

Note Step 7 applies only to pumps with six or more stages.

8. Continue the dismantling until shaft seal (pos. 105).
9. Remove shaft seal (pos. 105). See fig. 21.

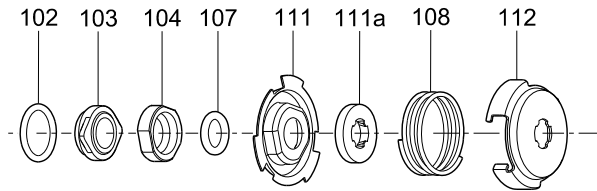

Fig. 21 Exploded view of shaft seal

10. Remove O-ring (pos. 31) and cover plate (pos. 32).

Note Dismantling of MG 71 and MG 80, see section 5.6.1.
Dismantling of MG 90, MG 100, MG 112 and MG 132, see section 5.7.1.

Note It is advisable always to replace wear rings (pos. 45) and wear ring retainers (pos. 65). See section 5.8.

5.5.2 Assembly

Note Assembly of MG 71 and MG 80, see section 5.6.2.
Assembly of MG 90, MG 100, MG 112 and MG 132, see section 5.7.2.

1. Fit cover plate (pos. 32) and O-ring (pos. 31). Lubricate the O-ring. See section 3. *Tightening torques and lubricants*.
2. Fit O-ring (pos. 102) on the stationary shaft seal part. See fig. 22. For correct lubricant, see section 3. *Tightening torques and lubricants*

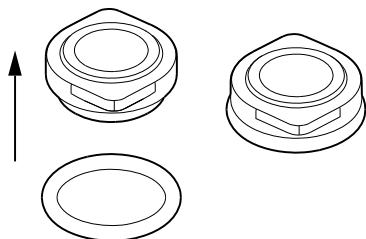

Fig. 22 Fitting the O-ring on the stationary shaft seal part

3. Press the stationary shaft seal part home. See fig. 23.



Warning
Do not touch the seal face.

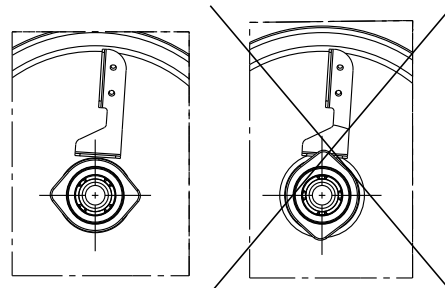

Fig. 23 Fitting the stationary shaft seal part (only SiC/SiC)

4. Fit the rotating shaft seal part (pos. 104) so that the seal face touches the stationary part.



Warning
Do not touch the seal face.

5. Fit O-ring (pos. 107) into the rotating shaft seal part (pos. 104). For correct lubricant, see section 3. *Tightening torques and lubricants*
6. Fit retainer (pos. 111) and stop ring (pos. 111a). See fig. 24.

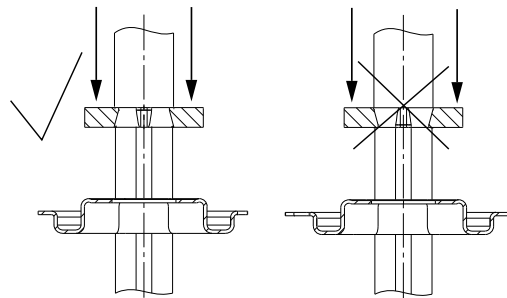

Fig. 24 Fitting the stop ring

7. Fit spring (pos. 108) and driver (pos. 112). See fig. 25.

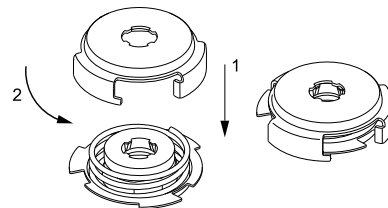

Fig. 25 Fitting the spring and driver

8. Fit short spacing pipe (pos. 64a), chamber with holes (pos. 4d) and impeller (pos. 49).
9. Continue the assembly until clamp (pos. 64c). For correct fitting of chambers and impellers, see section 8. *Order of assembly for chambers and impellers*.

TM04 4435 1909

TM04 4327 1909

TM04 4325 1909

TM04 4322 1909

TM04 4326 1909

10. Fit clamp (pos. 64c), washers (pos. 66) and nut (pos. 67).
See fig. 26.

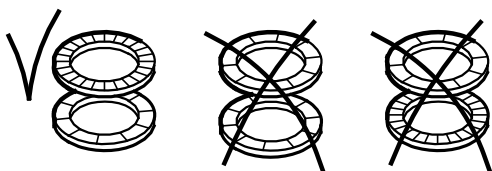

Fig. 26 Correct fitting of washers

11. Hold clamp (pos. 64c), and tighten nut (pos. 67).
See section 3. *Tightening torques and lubricants*.
12. Fit the chamber plate (pos. 4f).

Caution Do not forget to fit the chamber plate (pos. 4f), as it is possible to assemble the pump without the last chamber.

13. Fit sleeve (pos. 16) and clamping flange (pos. 6a).
14. Fit and cross-tighten staybolts (pos. 26). See section 3. *Tightening torques and lubricants*.

5.6 MG 71 and MG 80 motors

5.6.1 Dismantling

1. Remove screws (pos. 152).
2. Remove fan cover (pos. 151).
3. Remove fan (pos. 156) and seal ring (pos. 159a).
4. Remove screws (pos. 181).
5. Remove motor flange (pos. 156b) and gasket (pos. 157a).
6. Remove diverting disc (pos. 79), O-ring (pos. 158a) and bearing cover plate (pos. 155).
7. Pull shaft (pos. 51) out of stator housing (pos. 150).
8. Pull bearing (pos. 153) off shaft (pos. 51).
9. Remove O-ring (pos. 159) and spring (pos. 158).
10. Pull bearing (pos. 154) off shaft (pos. 51).

5.6.2 Assembly

1. Push bearing (pos. 154) onto shaft (pos. 51).
2. Fit spring (pos. 158) and O-ring (pos. 159). See fig. 27.

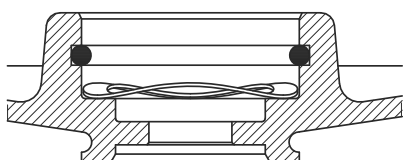

Fig. 27 Correct fitting of spring and O-ring

3. Push bearing (pos. 153) onto shaft (pos. 51).
4. Fit shaft (pos. 51) into stator housing (pos. 150).
5. Fit bearing cover plate (pos. 155), O-ring (pos. 158a) and diverting disc (pos. 79). Lubricate the surface of the cover plate (pos. 155) turning against the bearing. Lubricate the O-ring (pos. 158a).
For correct lubricant, see section 3. *Tightening torques and lubricants*.
6. Fit gasket (pos. 157a) and motor flange (pos. 156b).
7. Fit and cross-tighten screws (pos. 181). See section 3. *Tightening torques and lubricants*.
8. Fit and lubricate the seal ring (pos. 159a).
For correct lubricant, see section 3. *Tightening torques and lubricants*.
9. Fit the fan (pos. 156).
10. Fit fan cover (pos. 151).
11. Fit and tighten screws (pos. 152). See section 3. *Tightening torques and lubricants*.

5.7 MG 90, MG 100, MG 112 and MG 132 motors

5.7.1 Dismantling

1. Only cast iron pumps: Remove screws (pos. 2b).
2. Only cast iron pumps: Remove discharge part (pos. 2).
3. Remove screws (pos. 152).
4. Remove fan cover (pos. 151).
5. Remove fan (pos. 156) and seal ring (pos. 159a).
6. Remove staybolts (pos. 181).
7. Remove motor flange (pos. 156b), gasket (pos. 157a) and bearing cover (pos. 156a).
8. Remove diverting disc (pos. 79), O-ring (pos. 158a) and bearing cover plate (pos. 155).
9. Pull shaft (pos. 51) out of stator housing (pos. 150).
10. Pull bearing (pos. 153) off shaft (pos. 51).
11. Remove O-ring (pos. 159) and spring (pos. 158).
12. Pull bearing (pos. 154) off shaft (pos. 51).

5.7.2 Assembly

1. Push bearing (pos. 154) onto shaft (pos. 51).
2. Fit spring (pos. 158) and O-ring (pos. 159). See fig. 28.

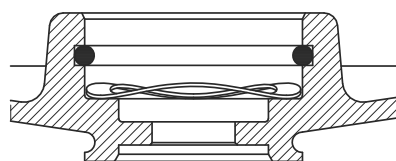

Fig. 28 Correct fitting of spring and O-ring

3. Push bearing (pos. 153) onto shaft (pos. 51).
4. Fit shaft (pos. 51) into stator housing (pos. 150).
5. Fit bearing cover plate (pos. 155), O-ring (pos. 158a) and diverting disc (pos. 79). Lubricate the surface of the cover plate (pos. 155) turning against the bearing. Lubricate the O-ring (pos. 158a).
For correct lubricant, see section 3. *Tightening torques and lubricants*.
6. Fit bearing cover (pos. 156a), gasket (pos. 157a) and motor flange (pos. 156b).
7. Fit and cross-tighten staybolts (pos. 181). See section 3. *Tightening torques and lubricants*.
8. Fit and lubricate the seal ring (pos. 159a). For correct lubricant, see section 3. *Tightening torques and lubricants*.
9. Fit the fan (pos. 156).
10. Fit fan cover (pos. 151).
11. Fit and tighten screws (pos. 152). See section 3. *Tightening torques and lubricants*.
12. Only cast iron pumps: Fit discharge part (pos. 2).
13. Only cast iron pumps: Fit and tighten screws (pos. 2b). See section 3. *Tightening torques and lubricants*.

TM02 1057 0501

TM04 4441 1209

TM04 4441 1209

5.8 Checking and replacing impellers and chambers

Check	Replace
Impeller	Wear ring/wear ring retainer
<ul style="list-style-type: none"> Check whether it is necessary to replace the impeller due to friction between wear ring and impeller skirt. If wear has caused a noticeable (use a finger nail) groove in the impeller skirt, the impeller should be replaced. It is advisable always to replace wear rings (pos. 45) and wear ring retainers (pos. 65) when the chamber stack is dismantled. 	<ol style="list-style-type: none"> Prise the wear ring retainer (pos. 65) up and free of the chamber using a screwdriver. Remove wear ring (pos. 45). Fit a new wear ring in the chamber. See fig. 29. Press a new wear ring retainer on the wear ring and into the chamber. <i>It must be possible to move the wear ring freely (sideways) between the retainer and the chamber.</i>
Bearing ring	
<ul style="list-style-type: none"> Check whether there is a visible and noticeable (use a finger nail) edge on the rotating bearing ring. 	<ul style="list-style-type: none"> Replace both bearing rings (pos. 47a) and chamber for bearing (pos. 4a).

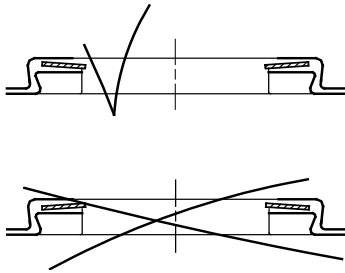

Fig. 29 Correct fitting of wear ring

TM02 1182 0601

6. Fault finding



Warning

Before removing the terminal box cover, make sure that the electricity supply has been switched off.

The pumped liquid may be scalding hot and under high pressure. Before any removal or dismantling of the pump, the system must therefore be drained, or the isolating valves on either side of the pump must be closed.

Fault	Cause	Remedy
1. The pump does not run.	a) Supply failure.	Switch on the switch. Check cables and cable connections for defects and loose connections.
	b) Fuses are blown.	Check cables and cable connections for defects, and replace the fuses.
	c) Motor protection tripped.	See 2. a), b), c), d), e), f).
	d) Control-current circuit defective.	Repair or replace the control-current circuit.
2. Motor-protective circuit breaker has tripped (trips out immediately when supply is switched on).	a) Fuses are blown.	See 1. b).
	b) Contacts of the motor-protective circuit breaker or magnet coil defective.	Replace the contacts of the motor-protective circuit breaker, the magnet coil or the entire motor-protective circuit breaker.
	c) Cable connection is loose or faulty.	Check cables and cable connections for defects, and replace the fuses.
	d) Motor winding is defective.	Repair or replace the motor.
	e) The pump is mechanically blocked.	Switch off the electricity supply, and clean or repair the pump.
	f) The setting of the motor-protective circuit breaker is too low.	Set the motor-protective circuit breaker according to the rated current of the motor ($I_{1/1}$). See nameplate.
3. The motor-protective circuit breaker trips out occasionally.	a) The setting of the motor-protective circuit breaker is too low.	See 2. f).
	b) Periodic supply failure.	See 2. c).
	c) Periodically low voltage.	Check cables and cable connections for defects and loose connections. Check that the supply cable of the pump is correctly sized.
4. The motor-protective circuit breaker has not tripped out, but the pump is inadvertently out of operation.	a) See 1. a), b), d) and 2. e).	
5. The pump performance is unstable.	a) Pump inlet pressure too low.	Check the inlet conditions of the pump.
	b) Inlet pipe is partly blocked by impurities.	Remove and clean the inlet pipe.
	c) Leakage in inlet pipe.	Remove and repair the inlet pipe.
	d) Air in inlet pipe or pump.	Vent the inlet pipe/pump. Check the inlet conditions of the pump.
6. The pump runs, but gives no water.	a) Pump inlet pressure too low.	See 5. a).
	b) Inlet pipe partly blocked by impurities.	See 5. b).
	c) The foot or non-return valve is stuck in its closed position.	Remove and clean, repair or replace the valve.
	d) Leakage in inlet pipe.	See 5. c).
	e) Air in inlet pipe or pump.	See 5. d).
7. The pump runs backwards when switched off.	a) Leakage in inlet pipe.	See 5. c).
	b) Foot or non-return valve defective.	See 6. c).
	c) The foot valve is stuck in completely or partly open position.	See 6. c).
8. The pump runs with reduced performance.	a) Wrong direction of rotation.	Three-phase pumps only: Switch off the electricity supply with the external circuit breaker and interchange two phases in the pump terminal box. It is possible to check the direction of rotation by means of the installation indicator. Black: The direction of rotation is correct. White: The direction of rotation is incorrect.
	b) See 5. a), b), c), d).	

7. Drawings

7.1 CM 1, 3, 5

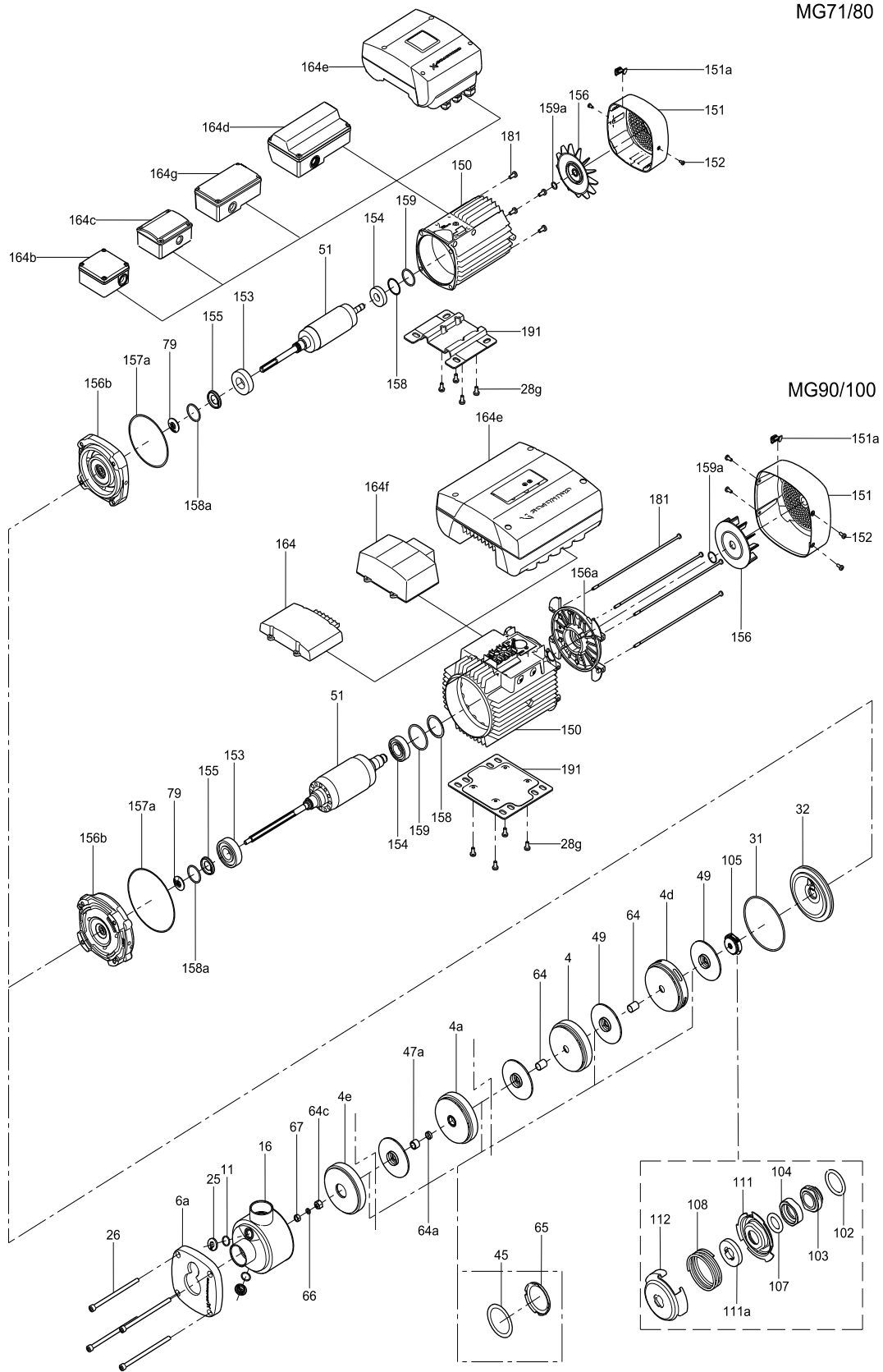

Fig. 30 CM 1, 3, 5, stainless steel

TM04 3588 4608

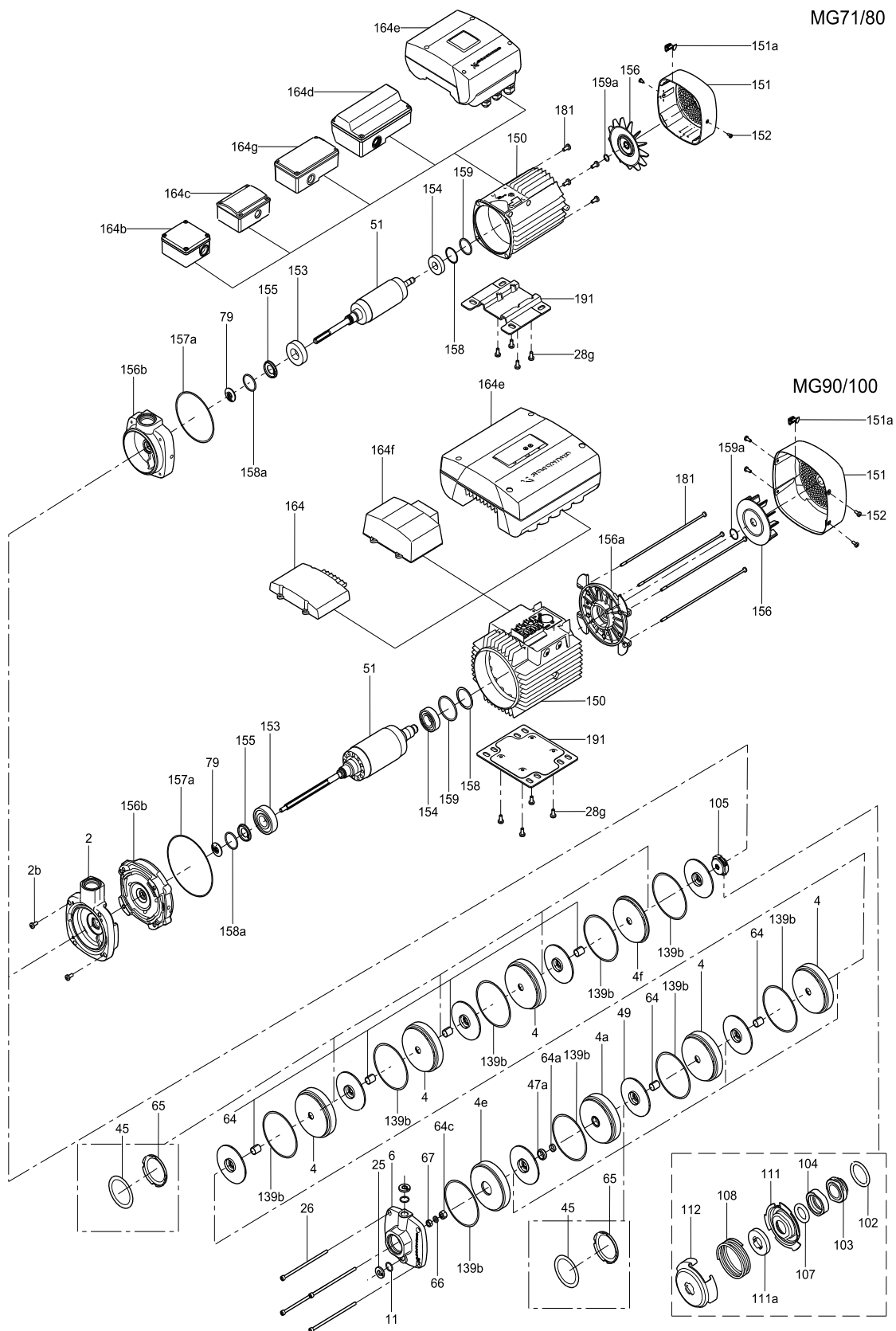

Fig. 31 CM 1, 3, 5, cast iron

TM04 3591 4608

7.2 CM 10, 15, 25

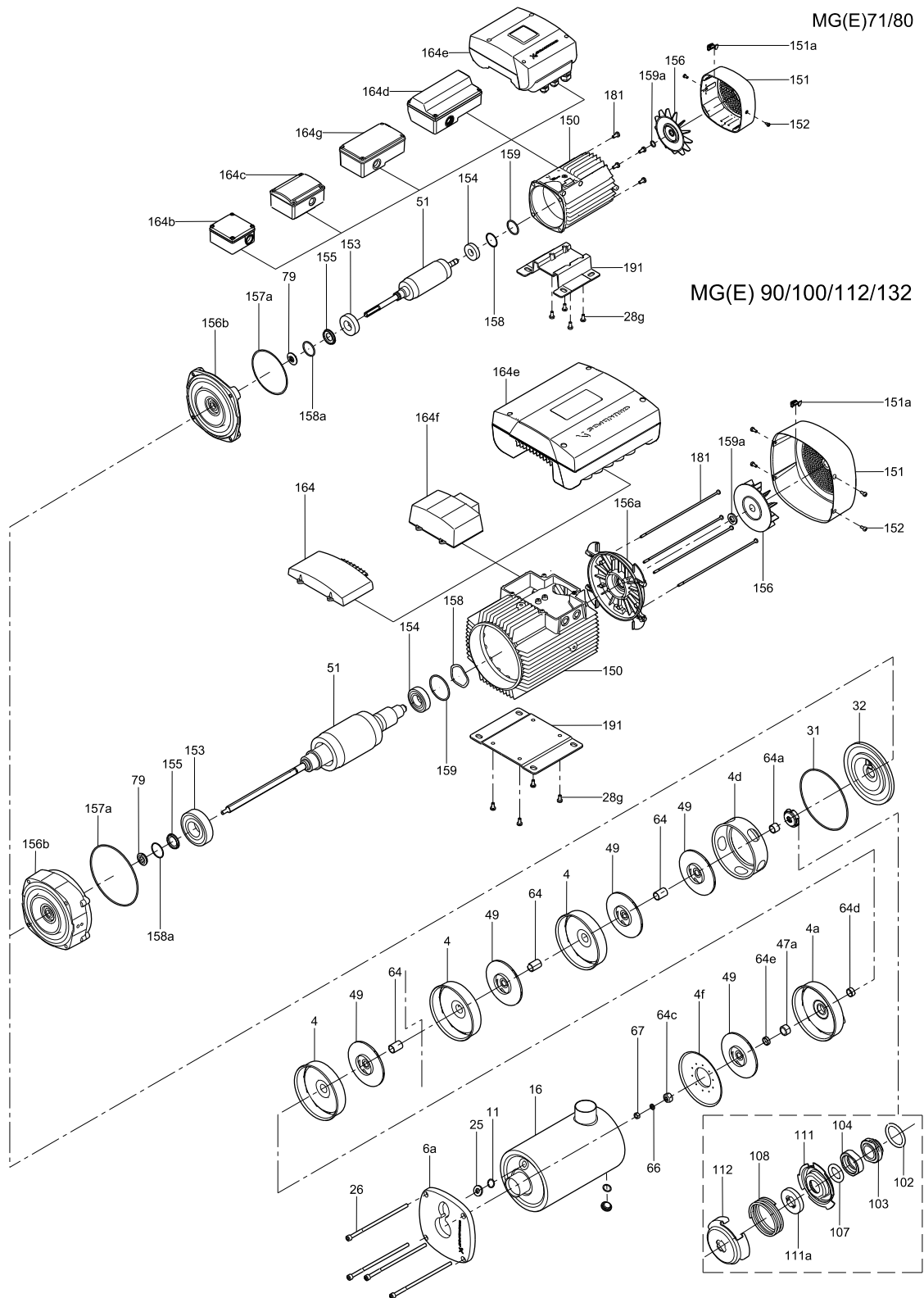

Fig. 32 CM 10, 15, 25, stainless steel

TM04 3828 5108

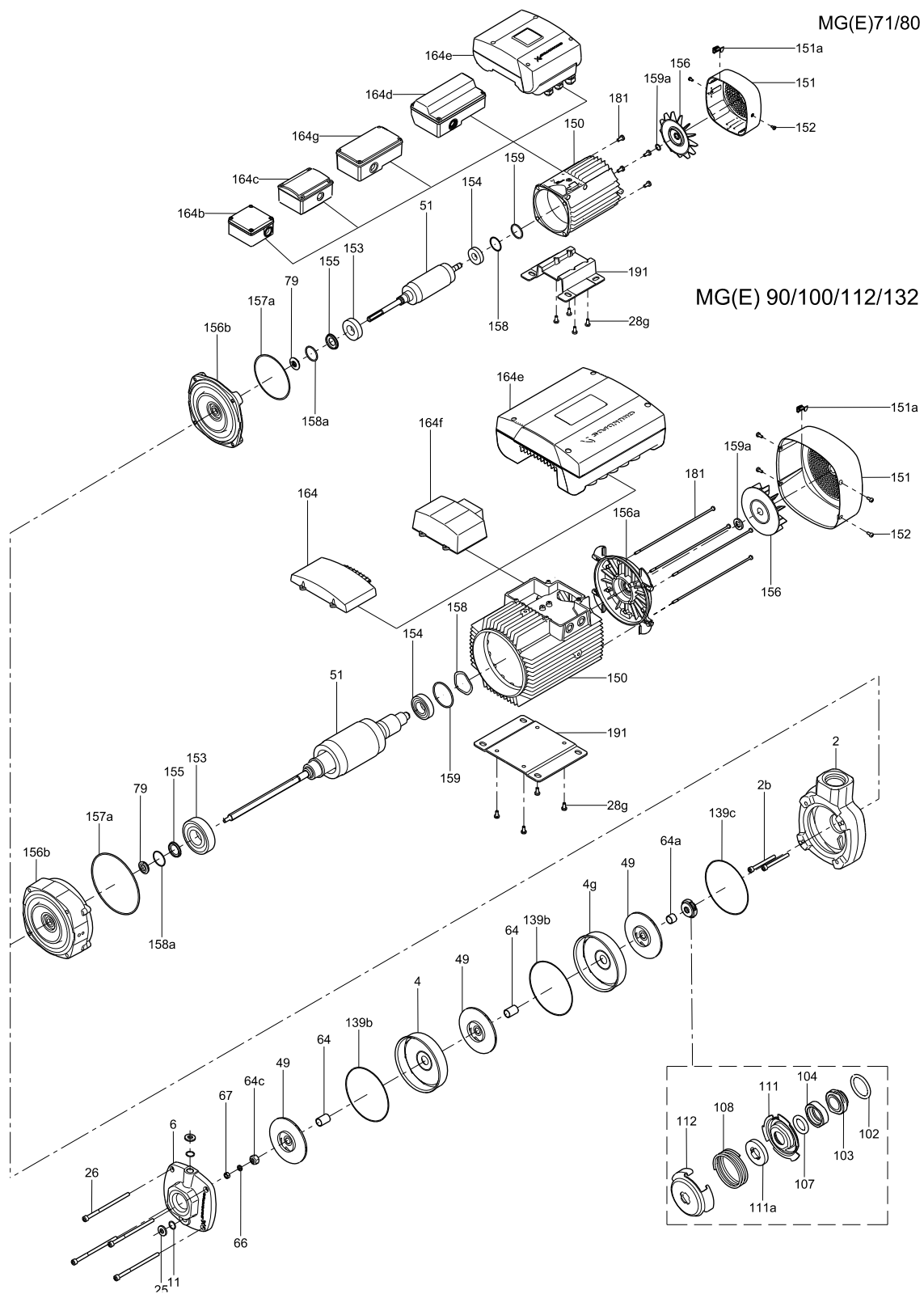

Fig. 33 CM 10, 15, 25, cast iron

TM04 3829 5108

8. Order of assembly for chambers and impellers

8.1 Key for CM 1, 3, 5

Bearings	
Chamber cpl.	A
Chamber with bearing cpl.	B
Chamber with holes	C
Chamber plate	D
Chamber without guide vanes	E
Impeller	F

8.2 CM 1, 3, 5, cast iron

CM 1, 3, 5, cast iron

Pos.	2		3		4		5		6		7		8	
	Chamber	Impeller	Chamber	Impeller	Chamber	Impeller	Chamber	Impeller	Chamber	Impeller	Chamber	Impeller	Chamber	Impeller
1*	D	F	D	F	D	F	D	F	D	F	D	F	D	F
2	E	F	A	F	A	F	A	F	A	F	A	F	A	F
3			E	F	A	F	A	F	A	F	A	F	A	F
4					E	F	A	F	A	F	A	F	A	F
5							E	F	A	F	A	F	A	F
6									E	F	A	F	A	F
7											E	F	B	F
8													E	F

* Pos. 1 is next to the motor.

8.3 CM 1, 3, 5, stainless steel

CM 1, 3, 5, stainless steel

Pos.	2		3		4		5		6		7		8	
	Chamber	Impeller	Chamber	Impeller	Chamber	Impeller	Chamber	Impeller	Chamber	Impeller	Chamber	Impeller	Chamber	Impeller
1*	C	F	C	F	C	F	C	F	C	F	C	F	C	F
2	E	F	A	F	A	F	A	F	A	F	A	F	A	F
3	E		E	F	A	F	A	F	A	F	A	F	A	F
4					E	F	A	F	A	F	A	F	A	F
5							E	F	A	F	A	F	A	F
6									E	F	A	F	A	F
7									E		E	F	B	F
8													E	F
9													E	

* Pos. 1 is next to the motor.

CM 1, 3, 5, stainless steel

Pos.	9		10		11		12		13		14	
	Chamber	Impeller	Chamber	Impeller	Chamber	Impeller	Chamber	Impeller	Chamber	Impeller	Chamber	Impeller
1*	C	F	C	F	C	F	C	F	C	F	C	F
2	A	F	A	F	A	F	A	F	A	F	A	F
3	A	F	A	F	A	F	A	F	A	F	A	F
4	A	F	A	F	A	F	A	F	A	F	A	F
5	A	F	A	F	A	F	A	F	A	F	A	F
6	A	F	A	F	A	F	A	F	A	F	A	F
7	A	F	A	F	A	F	A	F	A	F	A	F
8	B	F	A	F	A	F	A	F	A	F	A	F
9	E	F	B	F	A	F	A	F	A	F	A	F
10			E	F	B	F	A	F	A	F	A	F
11			E		E	F	B	F	B	F	B	F
12							E	F	A	F	A	F
13							E		E	F	A	F
14							E		E		E	F

* Pos. 1 is next to the motor.

8.4 Key for CM 10, 15, 25

Bearings	
Chamber cpl.	A
Chamber with bearing cpl.	B
Chamber with holes	C
Impeller located in cast iron component	D
Chamber without sand lift	E
Chamber plate, SS pumps	F
Chamber without guide vanes	G
Chamber without guide vanes and sand lift	H
Impeller	I

8.5 CM 10, 15, 25, cast iron

CM 10, 15, 25, cast iron

Pos.	1		2		3		4		5	
	Chamber	Impeller	Chamber	Impeller	Chamber	Impeller	Chamber	Impeller	Chamber	Impeller
1*	D	I	D	I	D	I	D	I	D	I
2	H		E	I	E	I	E	I	E	I
3					A	I	A	I	A	I
4							A	I	A	I
5									A	I

* Pos. 1 is next to the motor.

8.6 CM 10, 15, 25, stainless steel

CM 10, 15, 25, stainless steel

Pos.	1		2		3		4		5	
	Chamber	Impeller	Chamber	Impeller	Chamber	Impeller	Chamber	Impeller	Chamber	Impeller
1*	C	I	C	I	C	I	C	I	C	I
2	G		A	I	A	I	A	I	A	I
3	G		G		A	I	A	I	A	I
4	F		F		F		A	I	A	I
5							F		A	I
6									G	
7									F	

* Pos. 1 is next to the motor.

CM 10, 15, 25, stainless steel

Pos.	6		7		8	
	Chamber	Impeller	Chamber	Impeller	Chamber	Impeller
1*	C	I	C	I	C	I
2	A	I	A	I	A	I
3	A	I	A	I	A	I
4	A	I	A	I	A	I
5	A	I	A	I	A	I
6	B	I	A	I	A	I
7	F		B	I	A	I
8			G		B	I
9			F		F	

* Pos 1 is next to the motor.

Subject to alterations.

96957063 1011

GB

The name Grundfos, the Grundfos logo, and the payoff Be-Think-Innovate are registered trademarks owned by Grundfos Management A/S or Grundfos A/S, Denmark. All rights reserved worldwide.