

PROJECT: _____	UNIT TAG: _____	QUANTITY: _____
REPRESENTATIVE: _____	TYPE OF SERVICE: _____	DATE: _____
ENGINEER: _____	SUBMITTED BY: _____	DATE: _____
CONTRACTOR: _____	APPROVED BY: _____	DATE: _____
	ORDER NO.: _____	DATE: _____



CR 64-2

Vertical, multistage centrifugal pump with suction and discharge ports on the same level. The pump head and base are in cast iron. All other wetted parts are in stainless steel (EN 1.4301) (AISI 304)

Product photo could vary from the actual product

Conditions of Service	Pump Data	Motor Data
Flow: _____	Max pressure at stated temperature: 232 psi / 250 °F	Rated power - P2: 25 HP
Head: _____	Maximum ambient temperature: 104 °F	Rated voltage: 230/460 V
Efficiency: _____	Approvals: CURUS,NSF61	Main frequency: 60 Hz
Liquid: Water	Shaft seal: HQQE	Enclosure class: 23 >12.5mm/Spraying
Temperature: 68 °F	Product number: 96418850	Motor protection: NONE
NPSH required: ft		Motor type: BALDOR
Viscosity: _____		
Specific Gravity: 1.000		

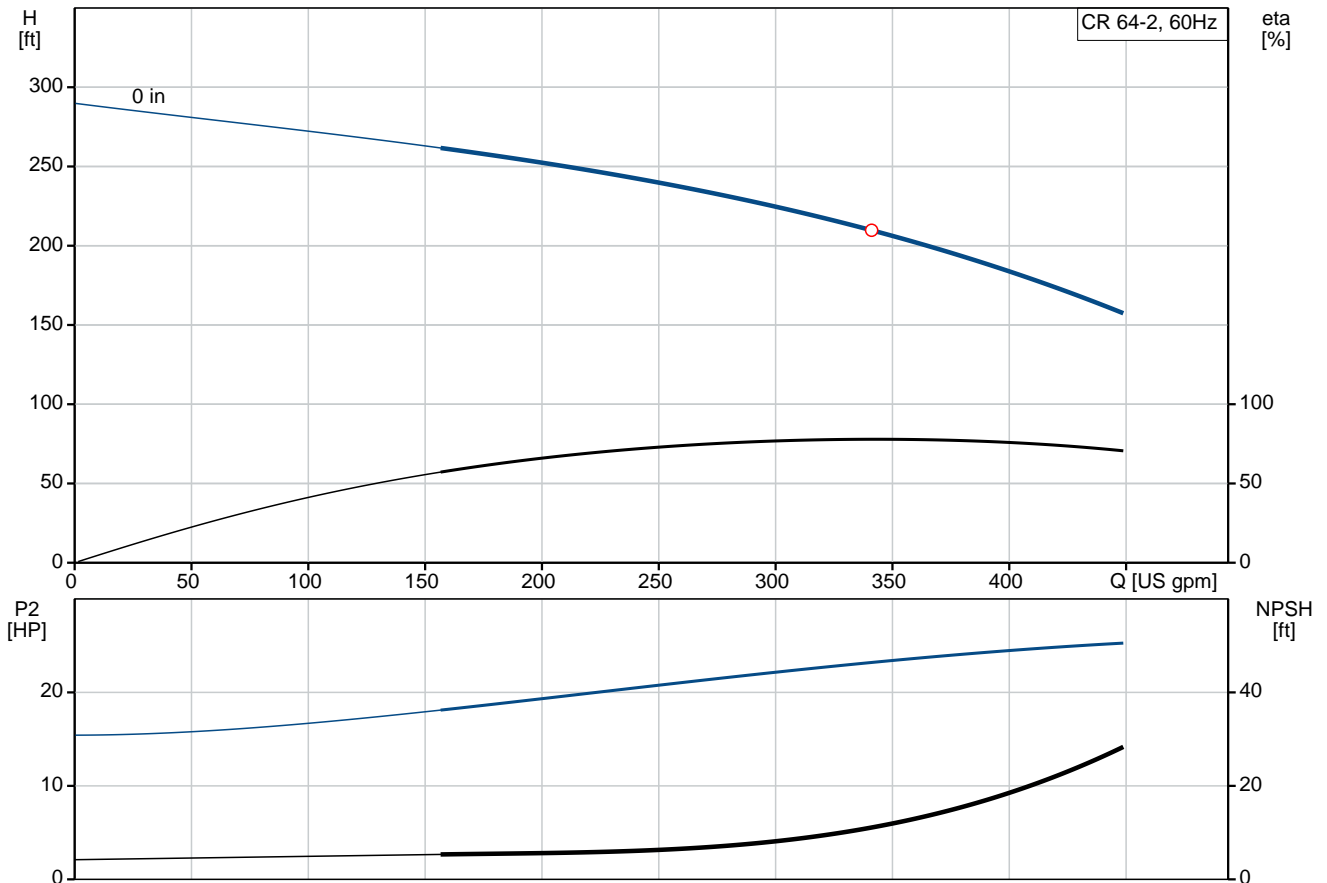

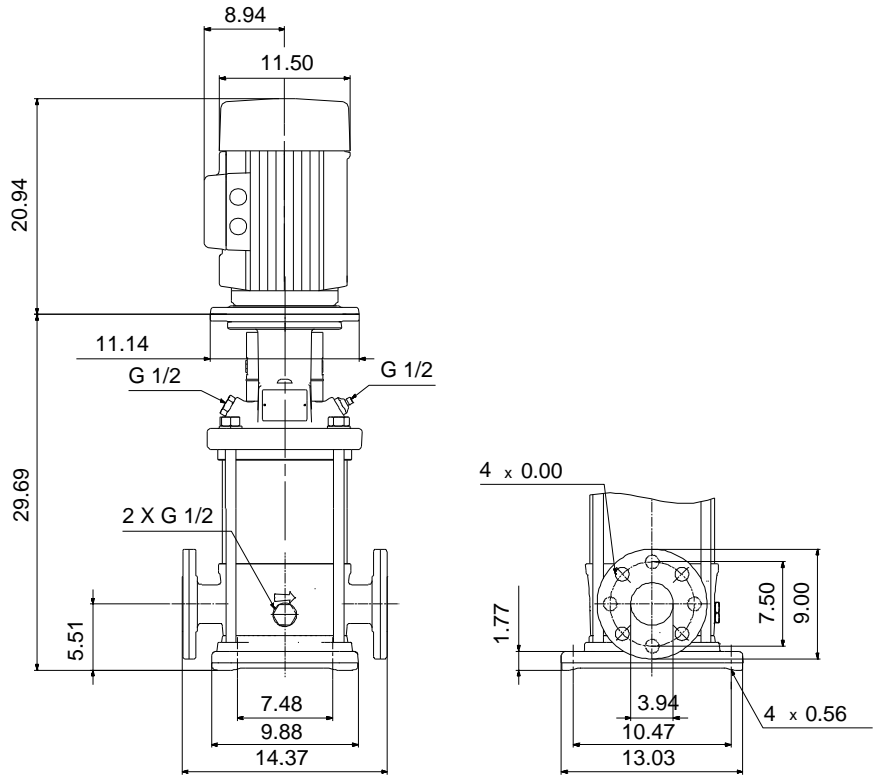

Materials:

Base:	Cast iron EN 1563 EN-GJS-500-7 ASTM A536 80-55-06
Impeller:	Stainless steel AISI 304 EN 1.4301
Material code:	A
Code for rubber:	E

Tender Text



Product No.: [96418850](#)

CR 64-2 A-G-A-E-HQQE

Vertical, non-self-priming, multistage, in-line, centrifugal pump for installation in pipe systems and mounting on a foundation.

The pump has the following characteristics:

- Impellers and intermediate chambers are made of
- The shaft seal has assembly length

according to EN 12756.

- Power transmission is via cast iron split coupling.

The motor is a 3-phase AC motor.

Controls:

Frequency converter: NONE

Liquid:

Pumped liquid: Water

Liquid temperature during operation: 68 °F

Density: 62.29 lb/ft³

Technical:

Speed for pump data: 3521 rpm

Pump orientation: Vertical

Shaft seal arrangement: Single

Code for shaft seal: HQQE

Approvals on nameplate: CURUS, NSF61

Curve tolerance: ISO9906:2012 3B

Materials:

Base: Cast iron
EN 1563 EN-GJS-500-7
ASTM A536 80-55-06

Impeller: Stainless steel
EN 1.4301

Bearing material: AISI 304

Support bearing: SIC

Support bearing: Graflon

Installation:

Maximum ambient temperature: 104 °F

Max pressure at stated temperature: 232 psi / 250 °F
232 psi / -22 °F

Type of connection: ANSI

Size of suction port: 4 inch

Size of outlet port: 4 inch



Company name:

Created by:

Phone:

Date:

2/20/2018

Pressure rating: PN 16
Flange size for motor: 284TC
Flange rating inlet: 150 lb

Electrical data:

Motor standard: NEMA
Motor type: BALDOR
IE Efficiency class: NEMA Premium / IE3 60Hz
Rated power - P2: 25 HP
Power (P2) required by pump: 25 HP
Main frequency: 60 Hz
Rated voltage: 3 x 230/460 V
Service factor: 1.15
Rated current: 56/28 A
Rated speed: 3520 rpm
Number of poles: 2
Enclosure class (IEC 34-5): 23 >12.5mm/Spraying

Others:

Net weight: 374 lb
Gross weight: 392 lb
Shipping volume: 17.5 ft³



Company name:

Created by:

Phone:

Date:

2/20/2018

Position	Count	Description
		Flange size for motor: 284TC Flange rating inlet: 150 lb
		Electrical data:
		Motor standard: NEMA
		Motor type: BALDOR
		IE Efficiency class: NEMA Premium / IE3 60Hz
		Rated power - P2: 25 HP
		Power (P2) required by pump: 25 HP
		Main frequency: 60 Hz
		Rated voltage: 3 x 230/460 V
		Service factor: 1.15
		Rated current: 56/28 A
		Rated speed: 3520 rpm
		Number of poles: 2
		Enclosure class (IEC 34-5): 23 >12.5mm/Spraying
		Others:
		Net weight: 374 lb
		Gross weight: 392 lb
		Shipping volume: 17.5 ft ³

96418850 CR 64-2 60 Hz

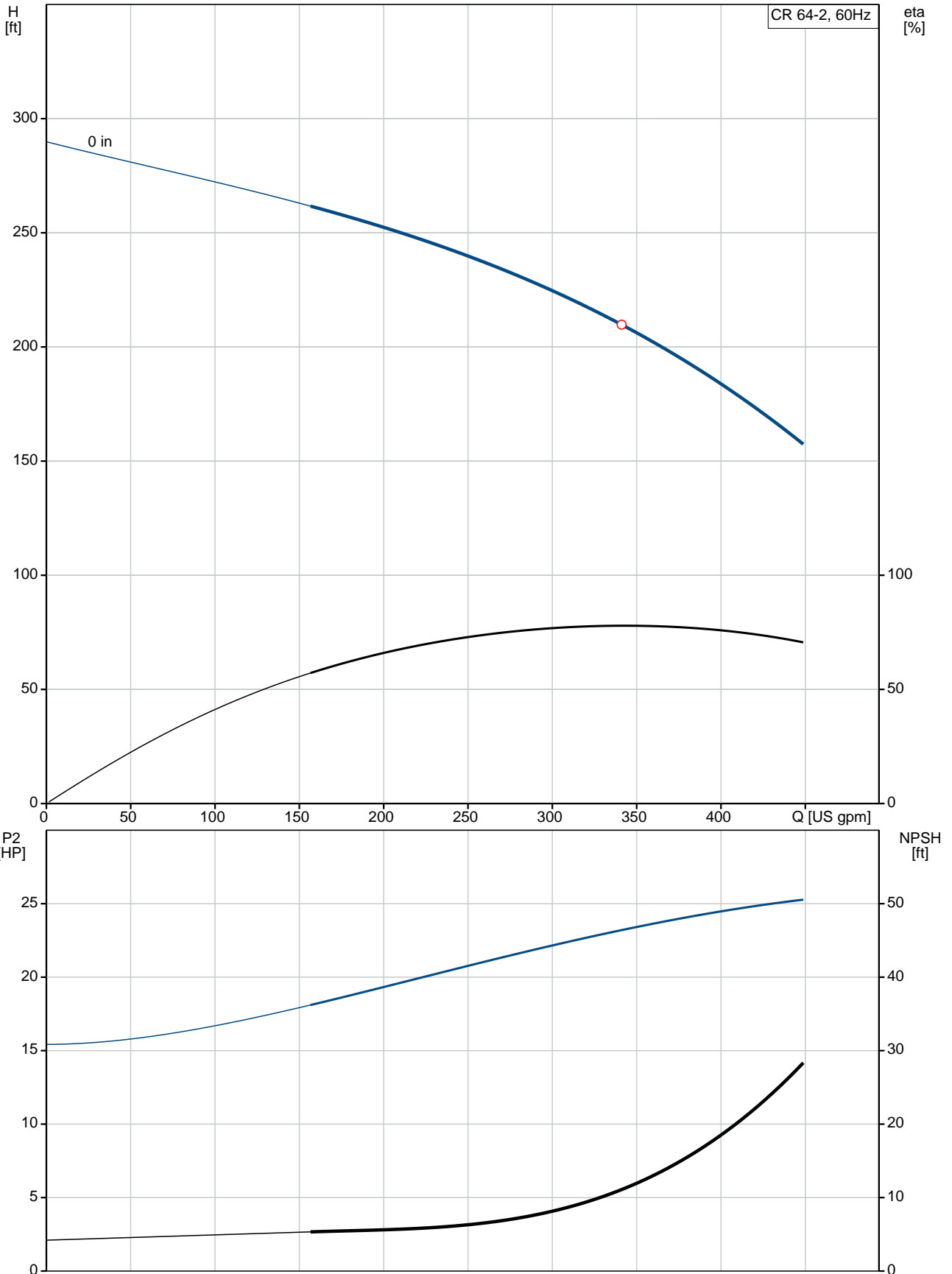

Description	Value
General information:	
Product name:	CR 64-2 A-G-A-E-HQQE
Product No.:	96418850
EAN:	5700390736965
Technical:	
Speed for pump data:	3521 rpm
Stages:	2
Impellers:	2
Low NPSH:	N
Pump orientation:	Vertical
Shaft seal arrangement:	Single
Code for shaft seal:	HQQE
Approvals on nameplate:	CURUS,NSF61
Curve tolerance:	ISO9906:2012 3B
Pump version:	A
Model:	B
Cooling:	ODP
Materials:	
Base:	Cast iron EN 1563 EN-GJS-500-7 ASTM A536 80-55-06
Impeller:	Stainless steel EN 1.4301 AISI 304
Material code:	A
Code for rubber:	E
Bearing material:	SIC
Support bearing:	Graflon
Installation:	
Maximum ambient temperature:	104 °F
Max pressure at stated temperature:	232 psi / 250 °F 232 psi / -22 °F
Type of connection:	ANSI
Connect code:	G
Size of suction port:	4 inch
Size of outlet port:	4 inch
Pressure rating:	PN 16
Flange size for motor:	284TC
Flange rating inlet:	150 lb
Liquid:	
Pumped liquid:	Water
Liquid temperature during operation:	68 °F
Density:	62.29 lb/ft ³
Electrical data:	
Motor standard:	NEMA
Motor type:	BALDOR
IE Efficiency class:	NEMA Premium / IE3 60Hz
Rated power - P2:	25 HP
Power (P2) required by pump:	25 HP
KVA code:	G
Main frequency:	60 Hz
Rated voltage:	3 x 230/460 V
Service factor:	1.15
Rated current:	56/28 A

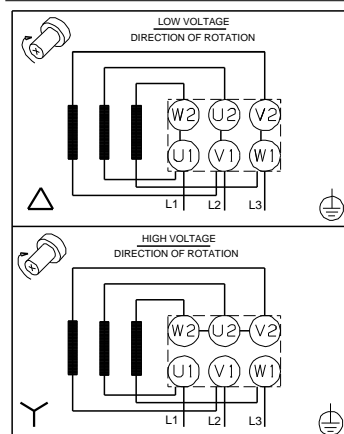
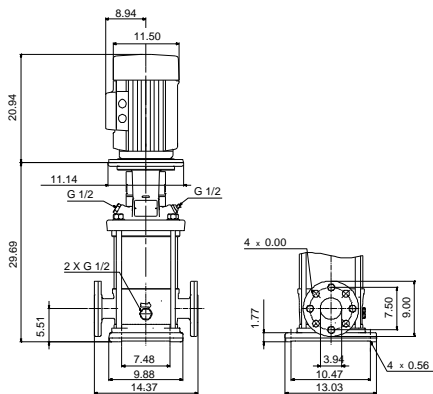
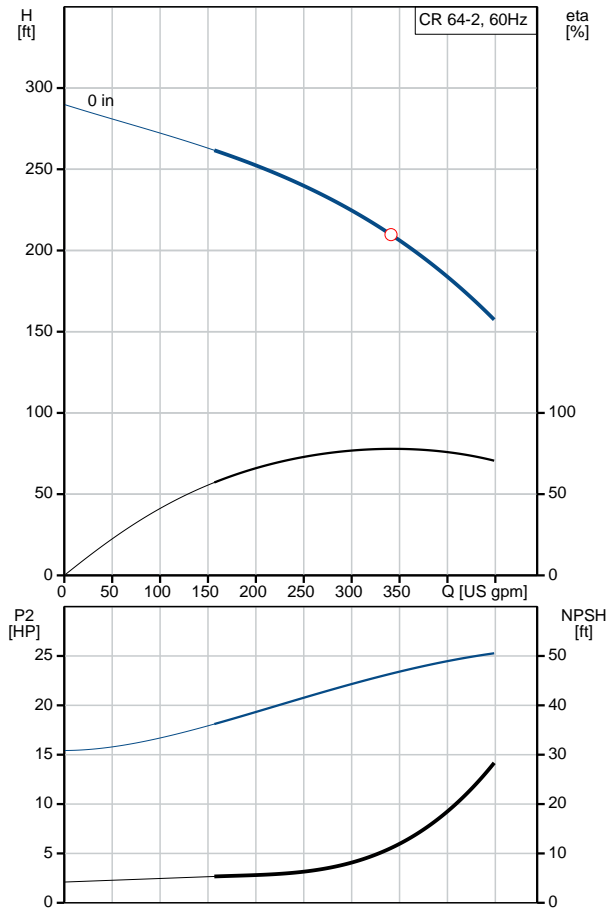



Company name:

Created by:

Phone:

Date:

2/20/2018

Description	Value
Load current:	62/31 A
Rated speed:	3520 rpm
Number of poles:	2
Enclosure class (IEC 34-5):	23 >12.5mm/Spraying
Motor protection:	NONE
Motor Number:	84Z00H21
Controls:	
Frequency converter:	NONE
Others:	
Net weight:	374 lb
Gross weight:	392 lb
Shipping volume:	17.5 ft ³
Sales region:	Namreg

96418850 CR 64-2 60 Hz

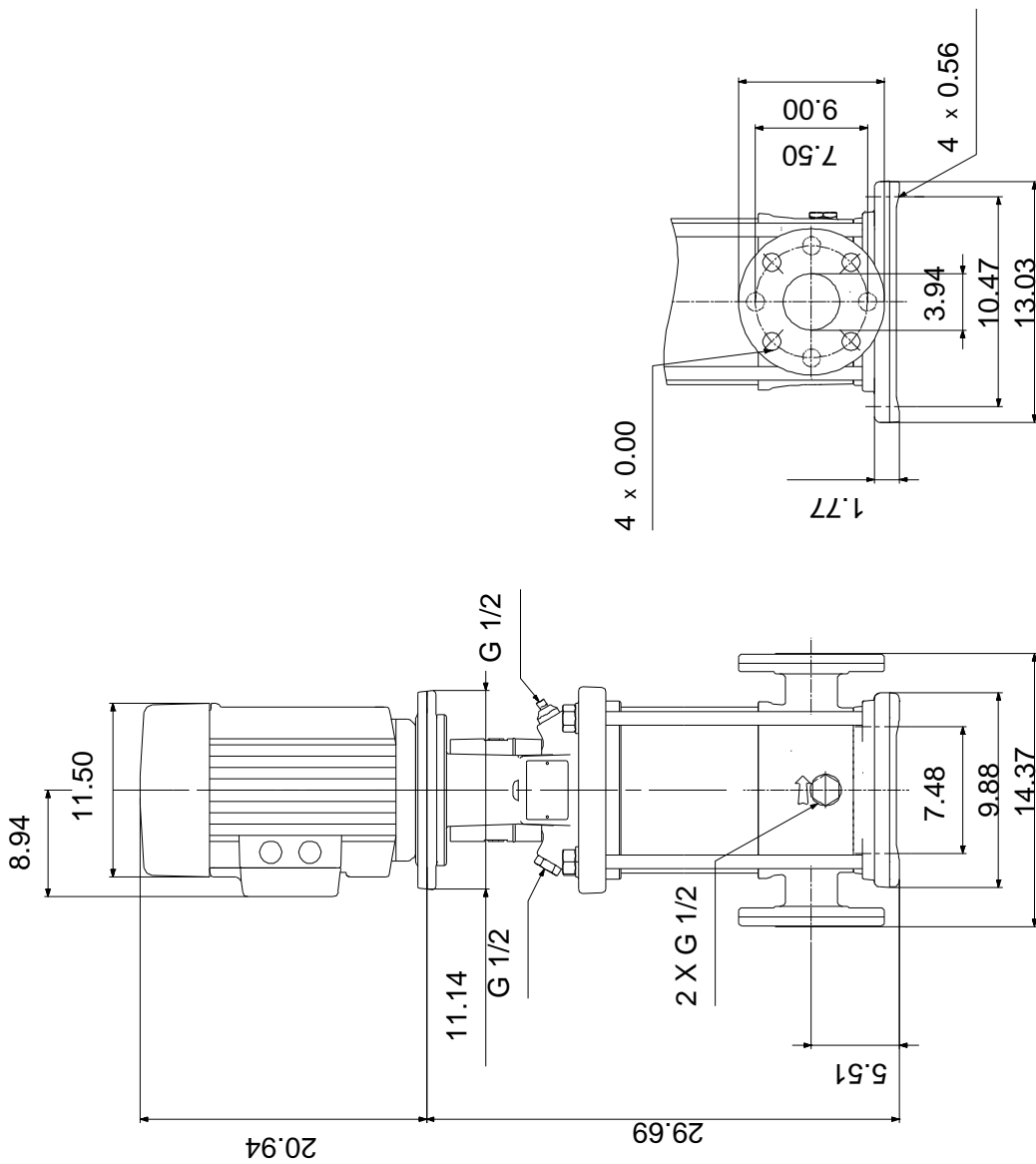

Note! All units are in [mm] unless otherwise stated.
 Disclaimer: This simplified dimensional drawing does not show all details.

96418850 CR 64-2 60 Hz

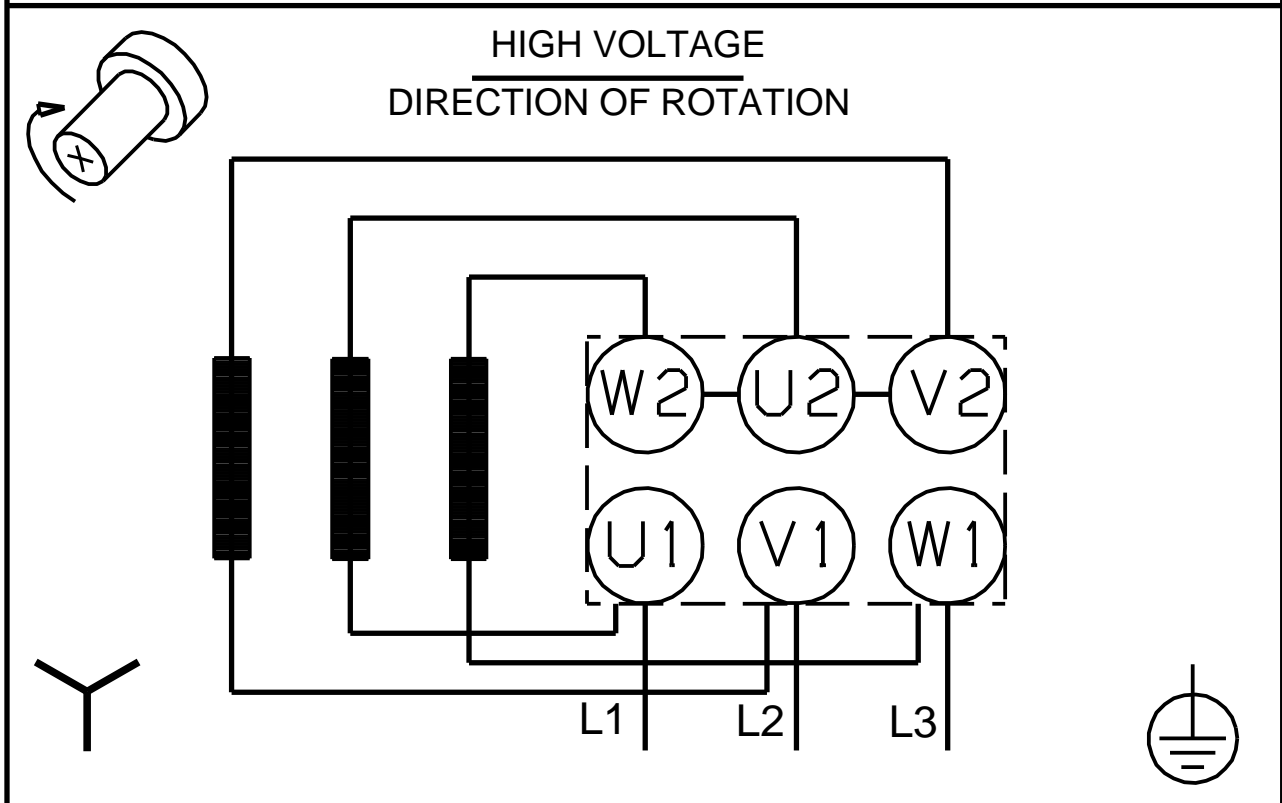
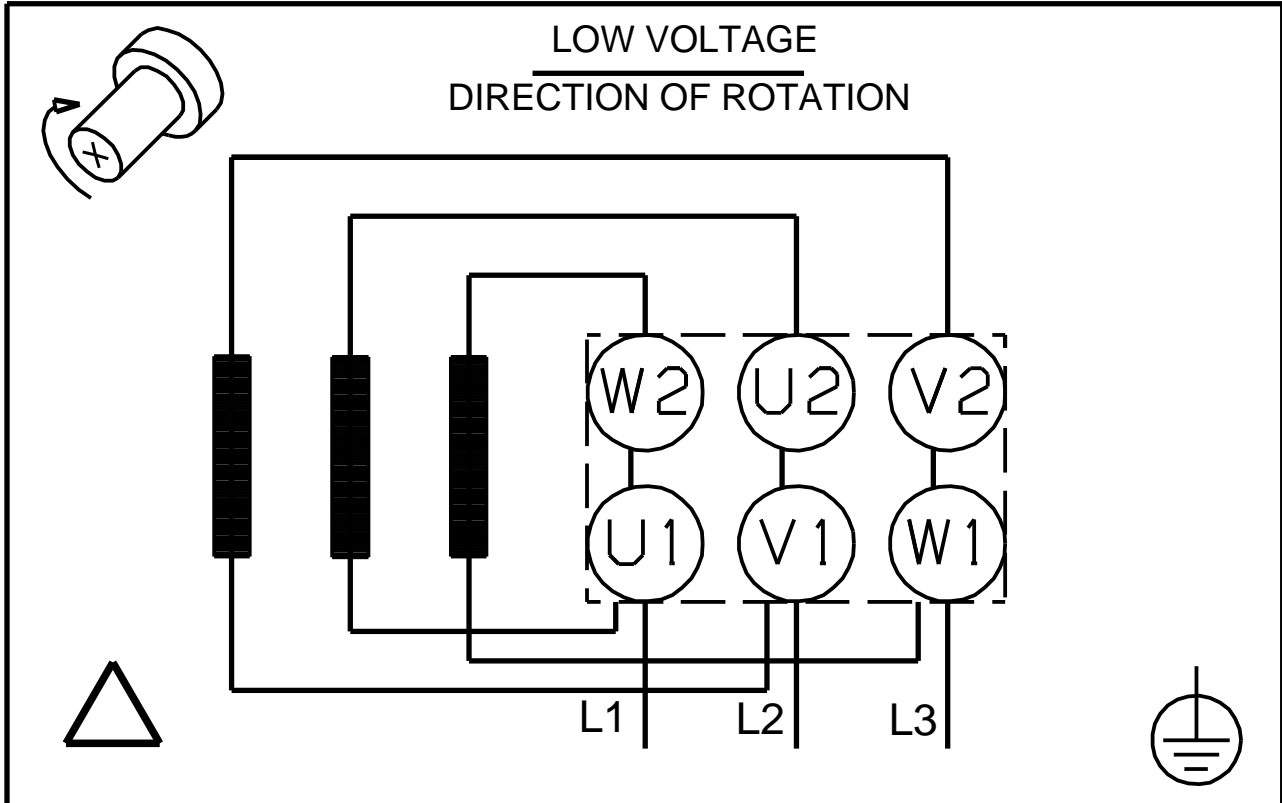

All units are [mm] unless otherwise presented.



Company name:

Created by:

Phone:

Date:

2/20/2018

Order Data:

Product name: CR 64-2 A-G-A-E-HQQE

Amount: 1

Product No.: 96418850

Total: Price on request

Exploded view (TM065558 LACR)

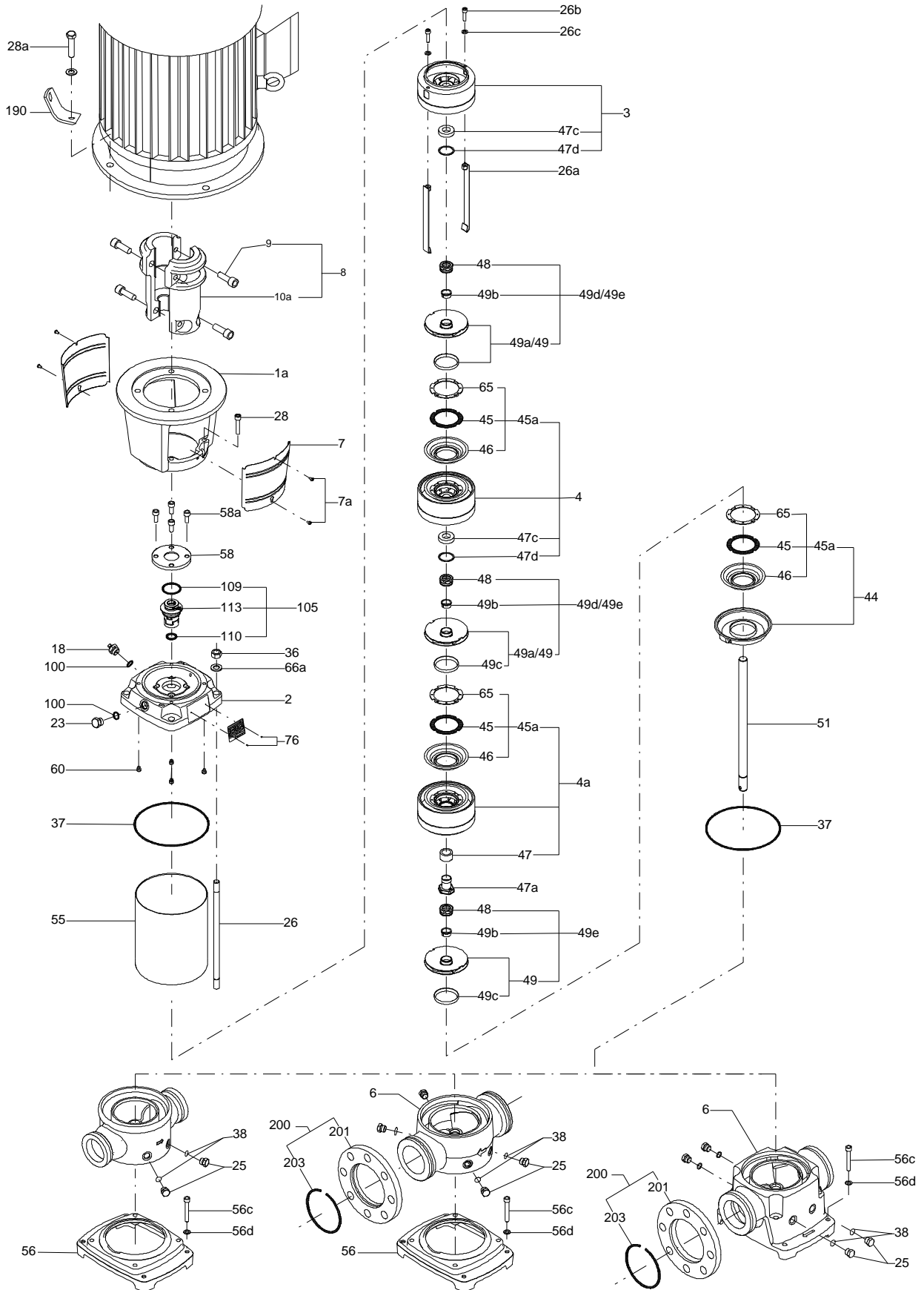

Sectional drawing (TM065571 LACR)

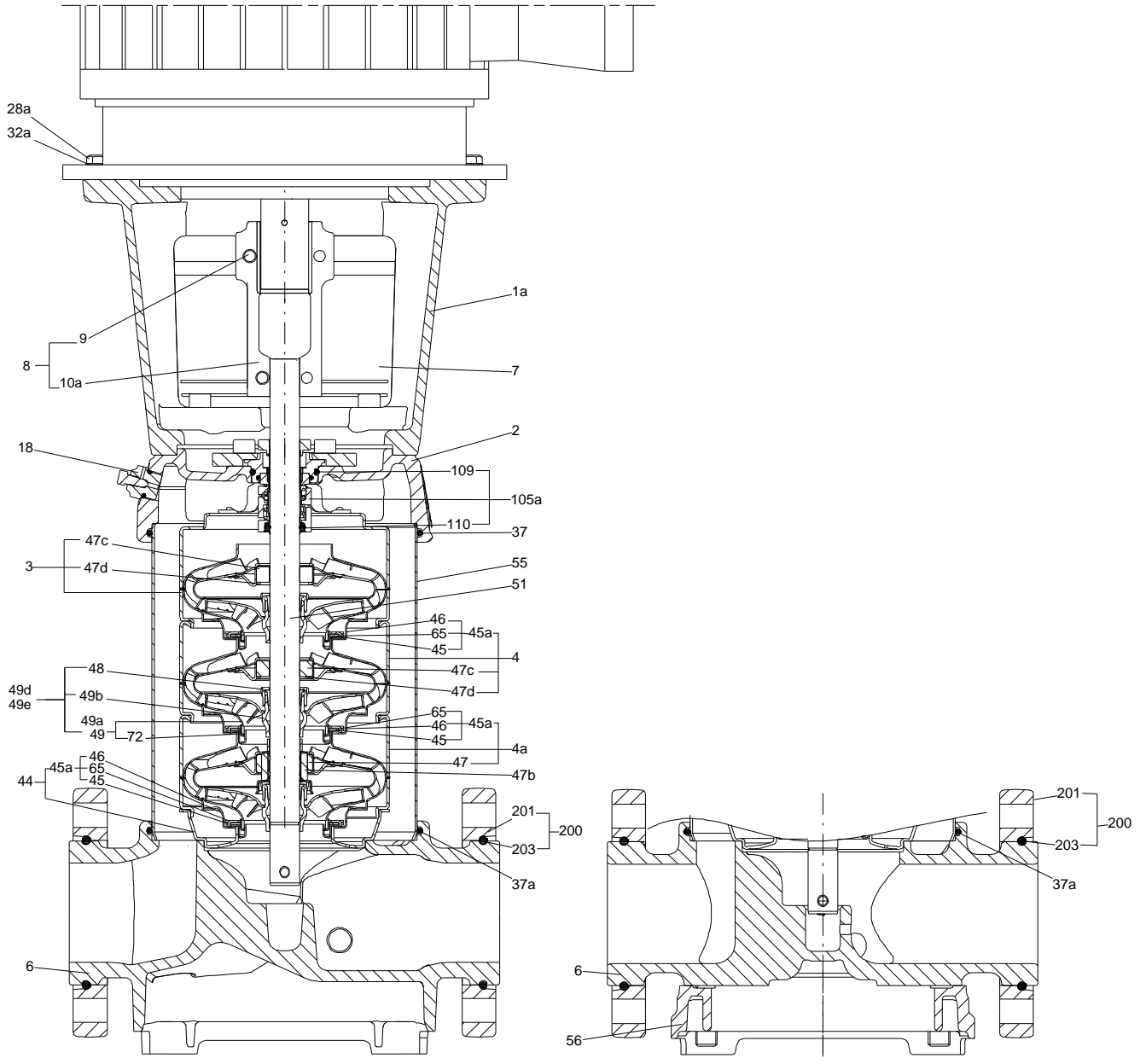

Parts list CR 64-2, Prod number 96418850

Valid from 3.3.2014 (1410)

Position	Description	Annotation	Classification data	Part No.	Count	Unit
	Motor				1	pcs
-	Flange cpl.				2	pcs
201	Flange		Pressure (bar): 150-4 Dimension: 229X25		1	
203	Lock ring				1	
- 1	Basic unit				1	pcs
- 2a	Pump head cpl.				1	
	O-ring					
2a	Pump head					
9	Hex socket head cap screw		Designation: DIN 912 Length: 25 Thread: M10			
- 18	Air vent screw					
	Plug					
	Spindle					
23	Plug					
58	Cover					
60	Spring					
100	O-ring		Diameter: 16,3 Material type: EPDM Thickness: 2,4			
- 6b	Base cpl.		Rubber type: EPDM		1	
	O-ring					
6	Base					
25	Plug					
32	Washer		Designation: DIN 125A Inner diameter: 6,4 Outer diameter: 12,0 Thickness: 1,6			
38	O-ring		Diameter: 16,3 Material type: EPDM Thickness: 2,4			
26	Staybolt		Length: 333 Thread: M16		4	
36	Hex nut		Thread: M16		4	
55	Outer sleeve		Outer diameter: 216,0 Length: 188,5		1	
66a	Washer		Designation: DIN 125 A Inner diameter: 17 Outer diameter: 30 Thickness: 3		4	
- 80	Chamber stack				1	
- 3	Upper chamber cpl.					
	Chamber					
	Guide vane					
	Cone					
	Guide cup					
	Guide cup					
3	Upper chamber cpl.					
47c	Bush					
47d	Lock ring					
- 4a	Intermediate chamber cpl.					
	Chamber					

Position	Description	Annotation	Classification data	Part No.	Count	Unit
	Chamber					
	Guide vane					
	Cone					
	Guide cup					
	Guide cup					
- 45a	Neck ring cpl.					
	Neck ring					
45	Seal ring					
65	Top f/neck ring					
47	Bearing					
26a	Strap cpl.		Length: 174,5 Thread: M8			
26b	Hex socket head cap screw					
26c	Washer		Designation: DIN 125A Inner diameter: 8,4 Outer diameter: 16 Thickness: 1,6			
- 44	Suction interconnector coupling					
	Neck ring					
	Inlet part					
45	Seal ring					
65	Top f/neck ring					
- 47a	Bearing cpl.					
	Disc spring					
	Bearing ring, rotating					
	Holder					
	Driver					
- 49e	Impeller cpl.					
48	Nut					
- 49	Impeller					
	Impeller hub					
49c	Wear ring					
49b	Split cone					
51	Shaft					
- 1a	Motor stool cpl.				1	pcs
1a	Motor stool				1	
7	Coupling guard				2	
7a	Socket button head screw				4	
28	Hex socket head cap screw		Designation: DIN 912 Length: 50 Thread: M10		4	
28a	Hex socket head cap screw		Length: 13 Thread: 1/2"		4	
- 8	Coupling cpl.		Dimension: 22/41,2		1	pcs
9	Hex socket head cap screw		Designation: DIN 912 Length: 25 Thread: M10		4	
10a	Coupling half				2	
- 105	Shaft seal		Material type: HQQE		1	pcs
	Adjusting fork				1	
109	O-ring				1	
110	O-ring		Diameter: 21,5 Material type: EPDM Thickness: 4,25		1	