

PROJECT: _____	UNIT TAG: _____	QUANTITY: _____
REPRESENTATIVE: _____	TYPE OF SERVICE: _____	DATE: _____
ENGINEER: _____	SUBMITTED BY: _____	DATE: _____
CONTRACTOR: _____	APPROVED BY: _____	DATE: _____
	ORDER NO.: _____	DATE: _____



**CR 90-2-2**

Vertical, multistage centrifugal pump with suction and discharge ports on the same level. The pump head and base are in cast iron. All other wetted parts are in stainless steel (EN 1.4301) (AISI 304)

Product photo could vary from the actual product

Conditions of Service		Pump Data		Motor Data	
Flow:	362 US gpm	Max pressure at stated temperature:	232 psi / 194 °F	Rated power - P2:	25 HP
Head:	170.3 ft	Maximum ambient temperature:	104 °F	Rated voltage:	230/460 V
Efficiency:	_____	Approvals:	CURUS	Main frequency:	60 Hz
Liquid:	Water	Shaft seal:	HQQV	Enclosure class:	54 Dust/Splashing
Temperature:	68 °F	Product number:	96418784	Insulation class:	F
NPSH required:	9.05 ft			Motor protection:	NONE
Viscosity:	_____			Motor type:	BALDOR
Specific Gravity:	1.000				

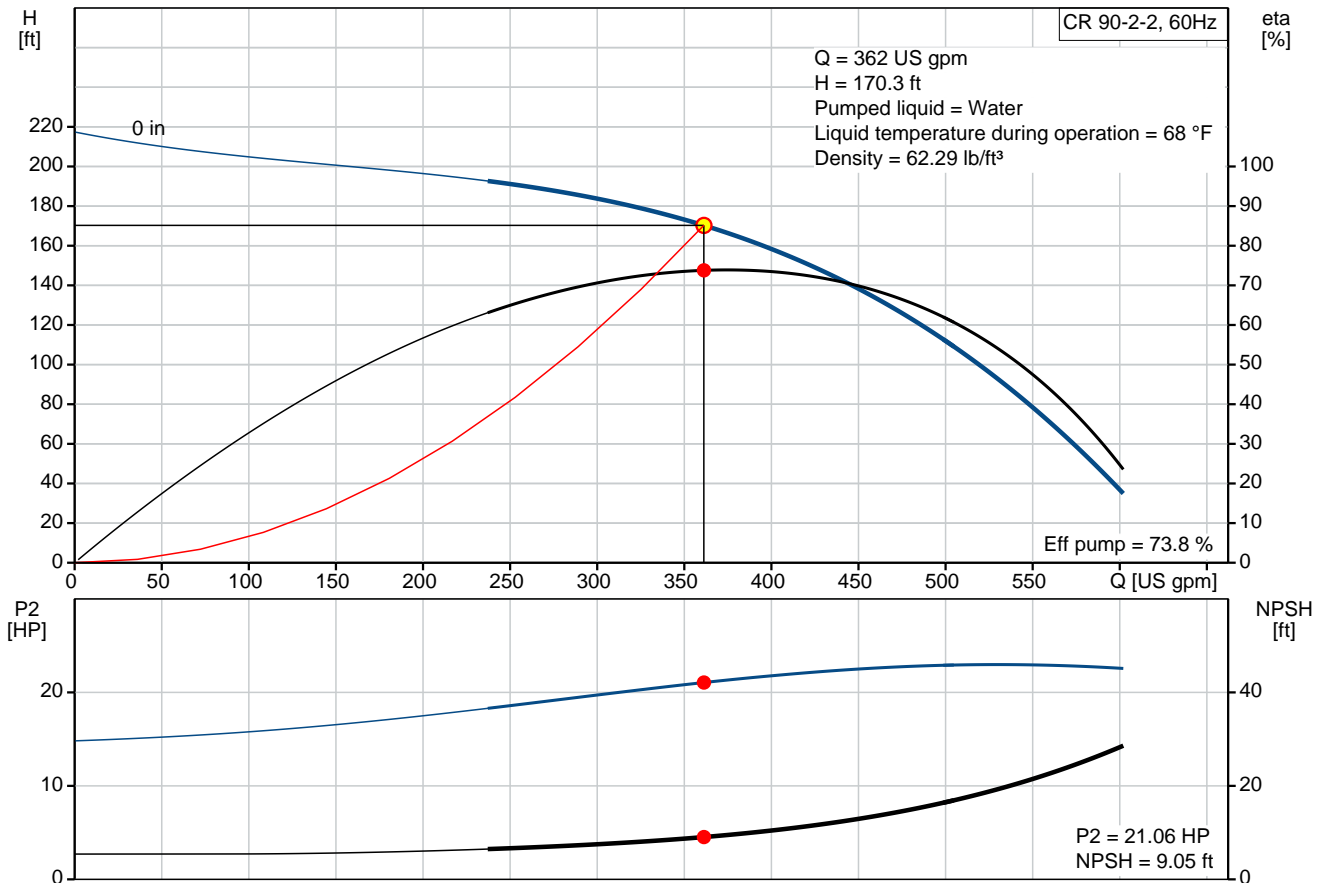

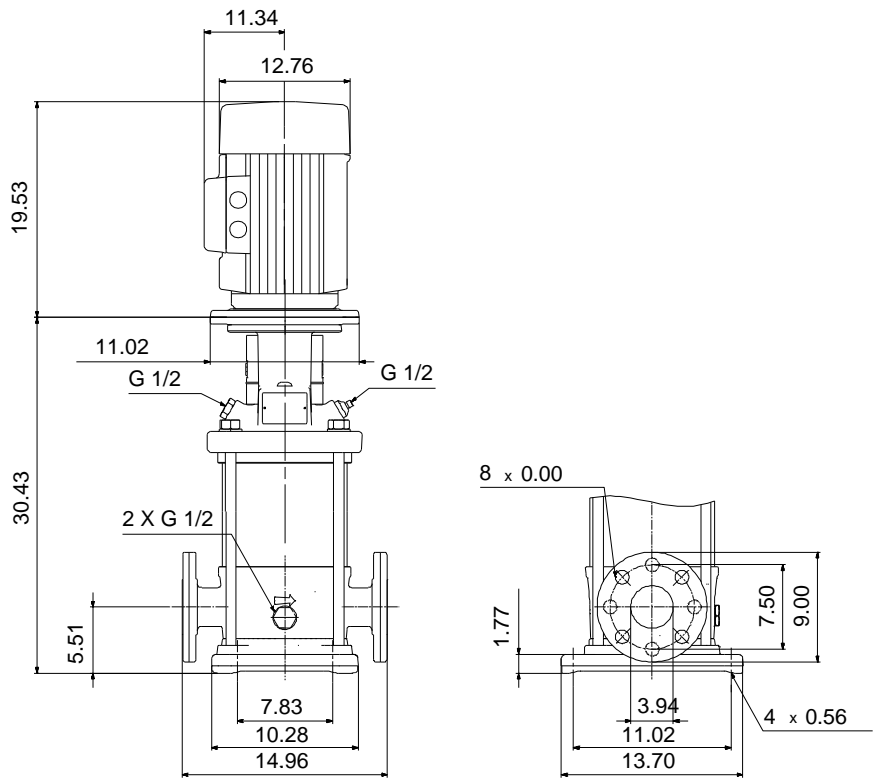

**Materials:**

Base:	Cast iron EN 1563 EN-GJS-500-7 ASTM A536 80-55-06
Impeller:	Stainless steel AISI 304 EN 1.4301
Material code:	A
Code for rubber:	V

## Tender Text



Product No.: [96418784](#)

### CR 90-2-2 A-G-A-V-HQQV

Vertical, non-self-priming, multistage, in-line, centrifugal pump for installation in pipe systems and mounting on a foundation.

The pump has the following characteristics:

- Impellers and intermediate chambers are made of
- The shaft seal has assembly length

according to EN 12756.

- Power transmission is via cast iron split coupling.

The motor is a 3-phase AC motor.

#### Controls:

Frequency converter: NONE

#### Liquid:

Pumped liquid: Water

Liquid temperature during operation: 68 °F

Density: 62.29 lb/ft<sup>3</sup>

#### Technical:

Speed for pump data: 3521 rpm

Actual calculated flow: 362 US gpm

Resulting head of the pump: 170.3 ft

Pump orientation: Vertical

Shaft seal arrangement: Single

Code for shaft seal: HQQV

Approvals on nameplate: CURUS

Curve tolerance: ISO9906:2012 3B

#### Materials:

Base: Cast iron  
EN 1563 EN-GJS-500-7  
ASTM A536 80-55-06

Impeller: Stainless steel  
EN 1.4301  
AISI 304

Bearing material: SIC

Support bearing: Graflon

#### Installation:

Maximum ambient temperature: 104 °F

Max pressure at stated temperature: 232 psi / 194 °F  
232 psi / -4 °F

Type of connection: ANSI



Company name:

Created by:

Phone:

Date:

2/20/2018

Size of suction port: 4 inch  
Size of outlet port: 4 inch  
Pressure rating: PN 16  
Flange size for motor: 284TC  
Flange rating inlet: 150 lb

**Electrical data:**

Motor standard: NEMA  
Motor type: BALDOR  
IE Efficiency class: NEMA Premium / IE3 60Hz  
Rated power - P2: 25 HP  
Power (P2) required by pump: 25 HP  
Main frequency: 60 Hz  
Rated voltage: 3 x 230/460 V  
Service factor: 1.15  
Rated current: 56/28 A  
Rated speed: 3530 rpm  
Number of poles: 2  
Enclosure class (IEC 34-5): 54 Dust/Splashing  
Insulation class (IEC 85): F

**Others:**

Net weight: 532 lb  
Gross weight: 550 lb  
Shipping volume: 29 ft<sup>3</sup>

Position	Count	Description
	1	<p><b>CR 90-2-2 A-G-A-V-HQQV</b></p>  <p>Product No.: <a href="#">96418784</a>            Vertical, non-self-priming, multistage, in-line, centrifugal pump for installation in pipe systems and mounting on a foundation.</p> <p>The pump has the following characteristics:</p> <ul style="list-style-type: none"> <li>- Impellers and intermediate chambers are made of</li> <li>- The shaft seal has assembly length according to EN 12756.</li> <li>- Power transmission is via cast iron split coupling.</li> </ul> <p>The motor is a 3-phase AC motor.</p> <p>Controls:            Frequency converter: NONE</p> <p><b>Liquid:</b>            Pumped liquid: Water            Liquid temperature during operation: 68 °F            Density: 62.29 lb/ft<sup>3</sup></p> <p><b>Technical:</b>            Speed for pump data: 3521 rpm            Actual calculated flow: 362 US gpm            Resulting head of the pump: 170.3 ft            Pump orientation: Vertical            Shaft seal arrangement: Single            Code for shaft seal: HQQV            Approvals on nameplate: CURUS            Curve tolerance: ISO9906:2012 3B</p> <p><b>Materials:</b>            Base: Cast iron                      EN 1563 EN-GJS-500-7                      ASTM A536 80-55-06            Impeller: Stainless steel                      EN 1.4301                      AISI 304            Bearing material: SIC            Support bearing: Graflon</p> <p><b>Installation:</b>            Maximum ambient temperature: 104 °F            Max pressure at stated temperature: 232 psi / 194 °F              232 psi / -4 °F</p> <p>Type of connection: ANSI            Size of suction port: 4 inch</p>



Company name:

Created by:

Phone:

Date:

2/20/2018

Position	Count	Description
		Size of outlet port: 4 inch Pressure rating: PN 16 Flange size for motor: 284TC Flange rating inlet: 150 lb
		<b>Electrical data:</b> Motor standard: NEMA Motor type: BALDOR IE Efficiency class: NEMA Premium / IE3 60Hz Rated power - P2: 25 HP Power (P2) required by pump: 25 HP Main frequency: 60 Hz Rated voltage: 3 x 230/460 V Service factor: 1.15 Rated current: 56/28 A Rated speed: 3530 rpm Number of poles: 2 Enclosure class (IEC 34-5): 54 Dust/Splashing Insulation class (IEC 85): F
		<b>Others:</b> Net weight: 532 lb Gross weight: 550 lb Shipping volume: 29 ft <sup>3</sup>



Company name:

Created by:

Phone:

Date:

2/20/2018

### 96418784 CR 90-2-2 60 Hz

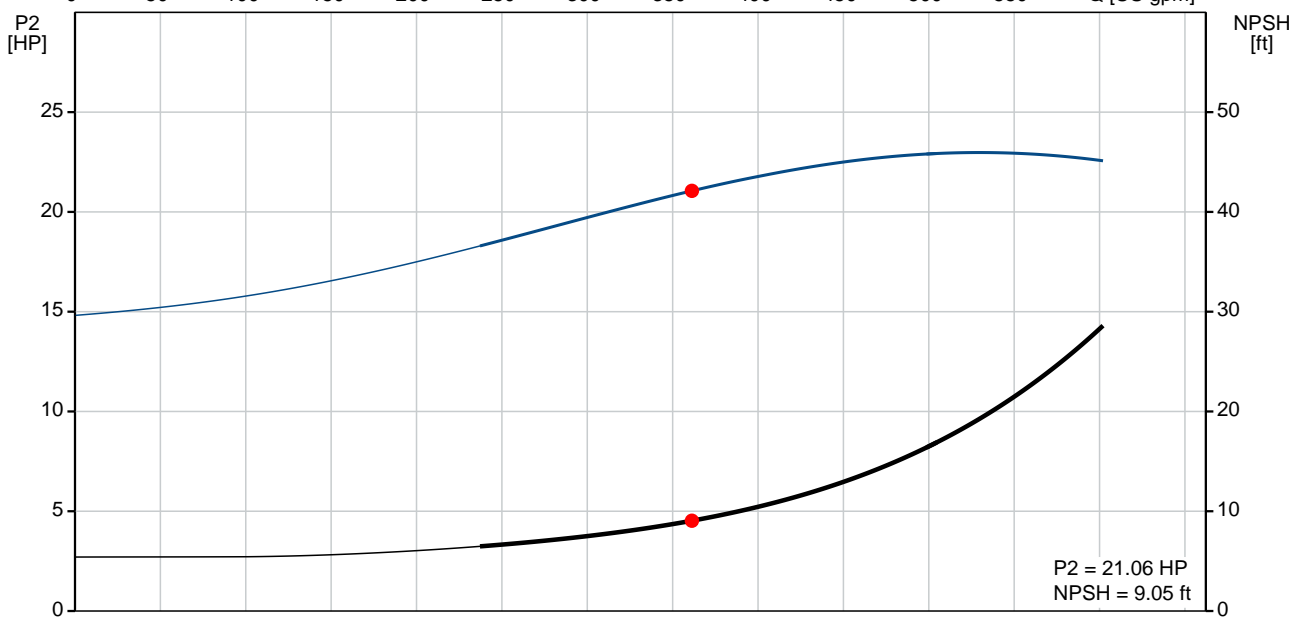
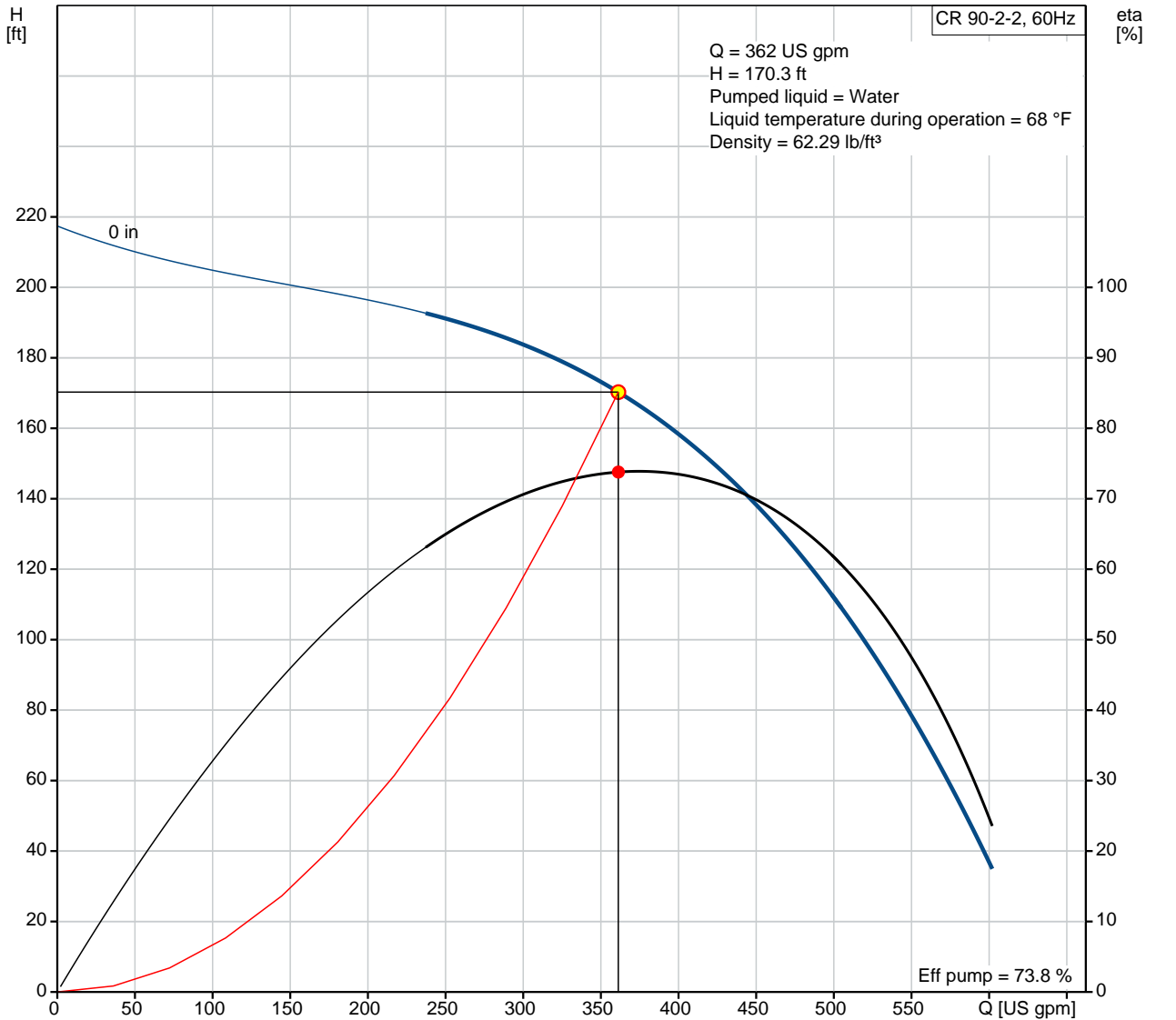

Description	Value
<b>General information:</b>	
Product name:	CR 90-2-2 A-G-A-V-HQQV
Product No.:	96418784
EAN:	5700390734275

<b>Technical:</b>	
Speed for pump data:	3521 rpm
Actual calculated flow:	362 US gpm
Resulting head of the pump:	170.3 ft
Stages:	2
Impellers:	2
Number of reduced-diameter impellers:	2
Low NPSH:	N
Pump orientation:	Vertical
Shaft seal arrangement:	Single
Code for shaft seal:	HQQV
Approvals on nameplate:	CURUS
Curve tolerance:	ISO9906:2012 3B
Pump version:	A
Model:	B
Cooling:	TEFC

<b>Materials:</b>	
Base:	Cast iron EN 1563 EN-GJS-500-7 ASTM A536 80-55-06
Impeller:	Stainless steel EN 1.4301 AISI 304
Material code:	A
Code for rubber:	V
Bearing material:	SIC
Support bearing:	Graflon

<b>Installation:</b>	
Maximum ambient temperature:	104 °F
Max pressure at stated temperature:	232 psi / 194 °F 232 psi / -4 °F
Type of connection:	ANSI
Connect code:	G
Size of suction port:	4 inch
Size of outlet port:	4 inch
Pressure rating:	PN 16
Flange size for motor:	284TC
Flange rating inlet:	150 lb

<b>Liquid:</b>	
Pumped liquid:	Water
Liquid temperature during operation:	68 °F
Density:	62.29 lb/ft <sup>3</sup>

<b>Electrical data:</b>	
Motor standard:	NEMA
Motor type:	BALDOR
IE Efficiency class:	NEMA Premium / IE3 60Hz
Rated power - P2:	25 HP
Power (P2) required by pump:	25 HP
KVA code:	J

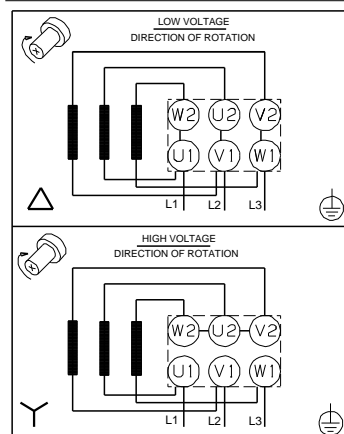
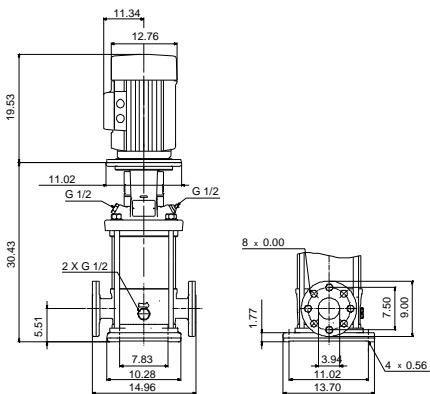
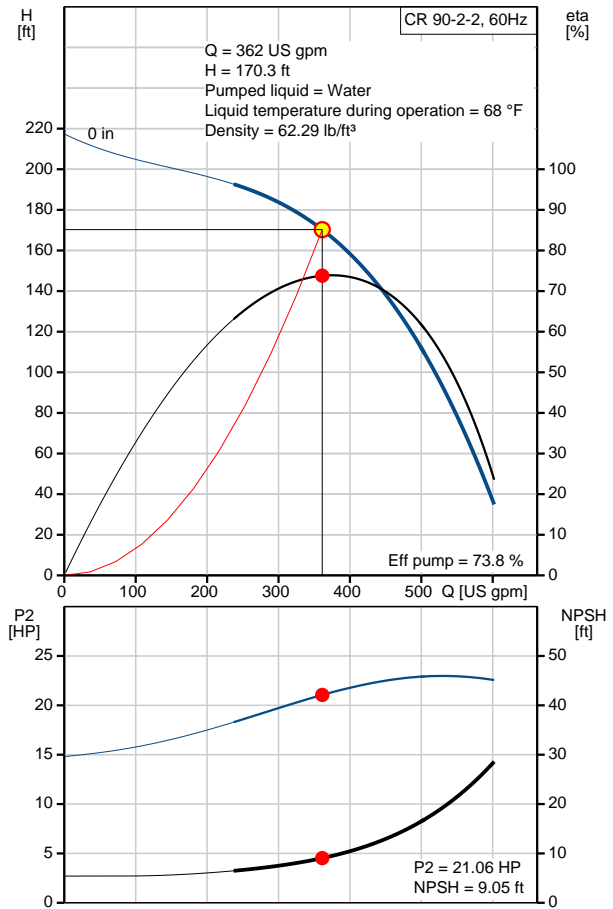





Company name:

Created by:

Phone:

Date:

2/20/2018

Description	Value
Main frequency:	60 Hz
Rated voltage:	3 x 230/460 V
Service factor:	1.15
Rated current:	56/28 A
Load current:	64.4/32.2 A
Rated speed:	3530 rpm
Number of poles:	2
Enclosure class (IEC 34-5):	54 Dust/Splashing
Insulation class (IEC 85):	F
Motor protection:	NONE
Motor Number:	85600H26
<b>Controls:</b>	
Frequency converter:	NONE
<b>Others:</b>	
Net weight:	532 lb
Gross weight:	550 lb
Shipping volume:	29 ft <sup>3</sup>
Sales region:	Namreg

**96418784 CR 90-2-2 60 Hz**

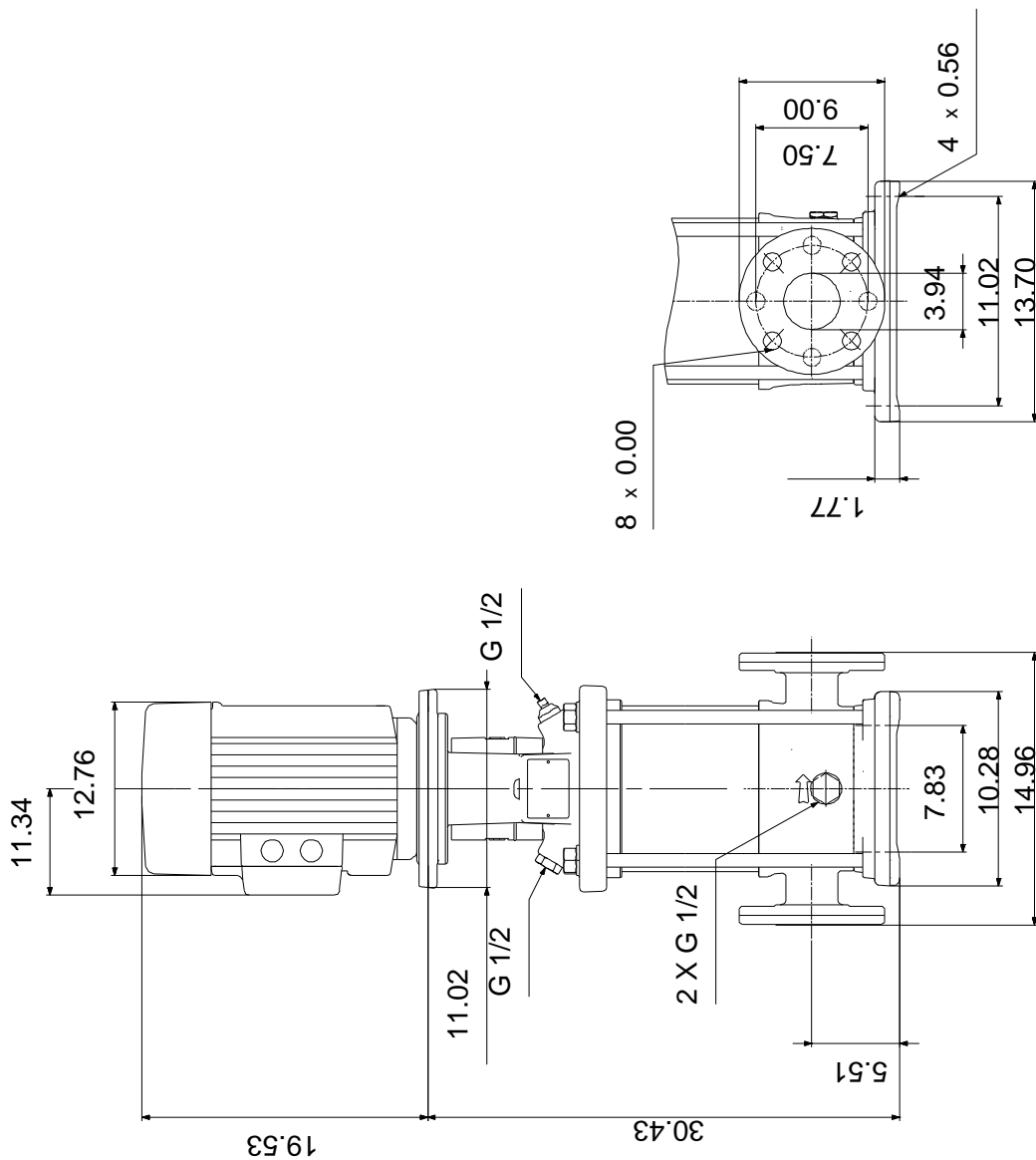

Note! All units are in [mm] unless otherwise stated.  
Disclaimer: This simplified dimensional drawing does not show all details.

**96418784 CR 90-2-2 60 Hz**

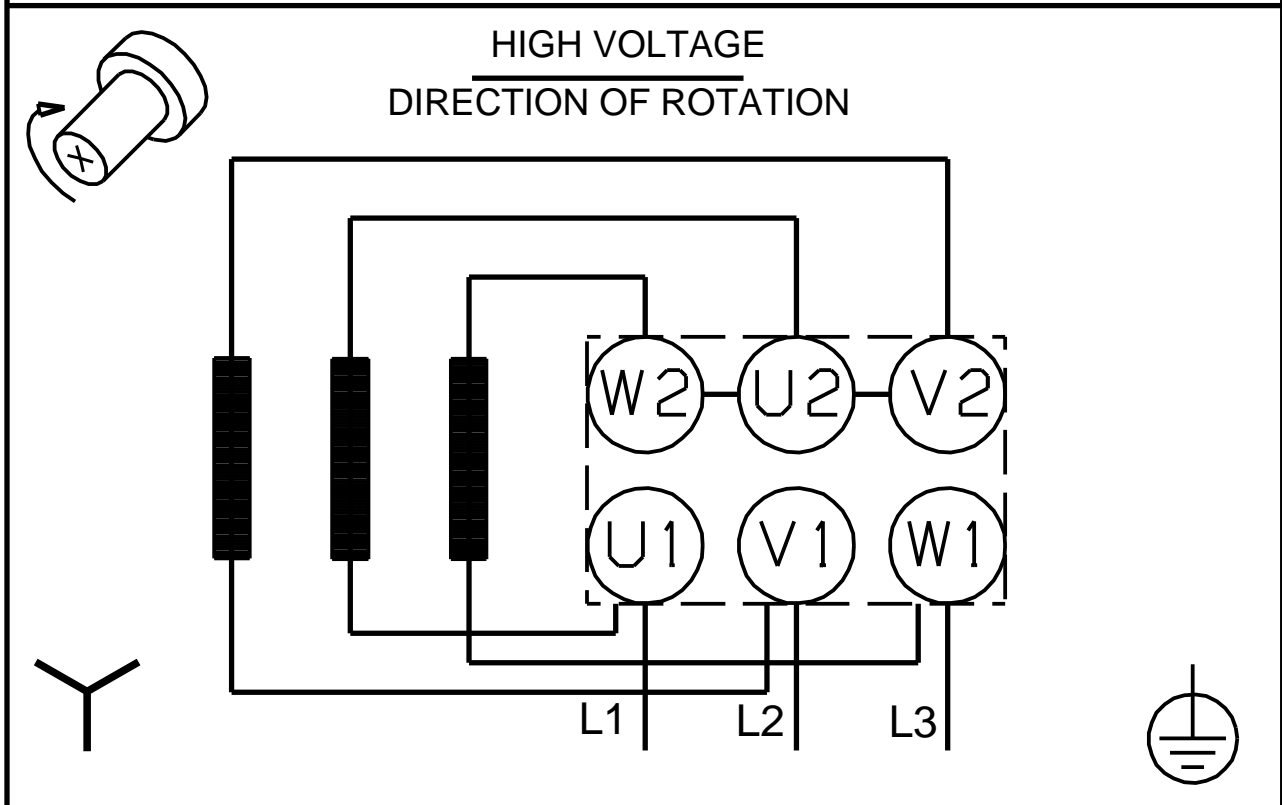
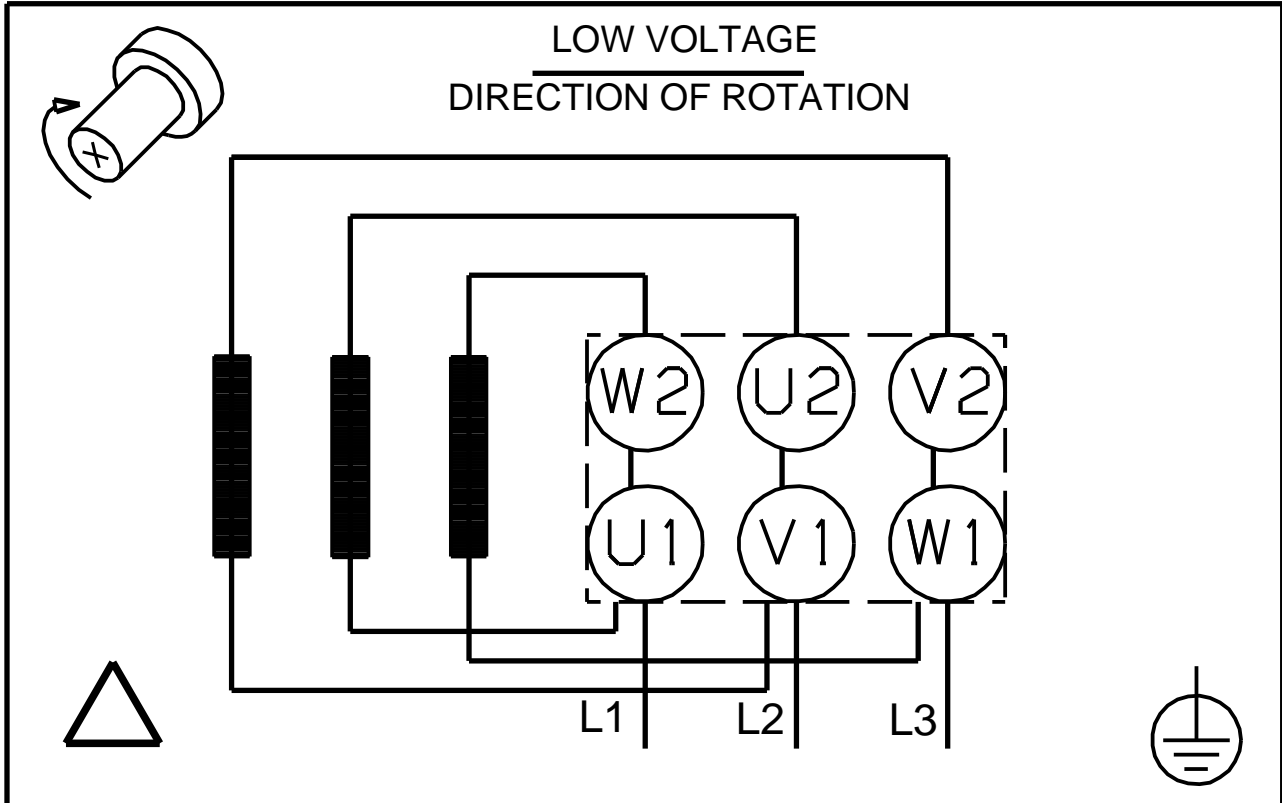

All units are [mm] unless otherwise presented.



Company name:

Created by:

Phone:

Date: 2/20/2018

---

**Order Data:**

Product name: CR 90-2-2 A-G-A-V-HQQV

Amount: 1

Product No.: 96418784

Total: Price on request

---

## Exploded view (TM065558 LACR )

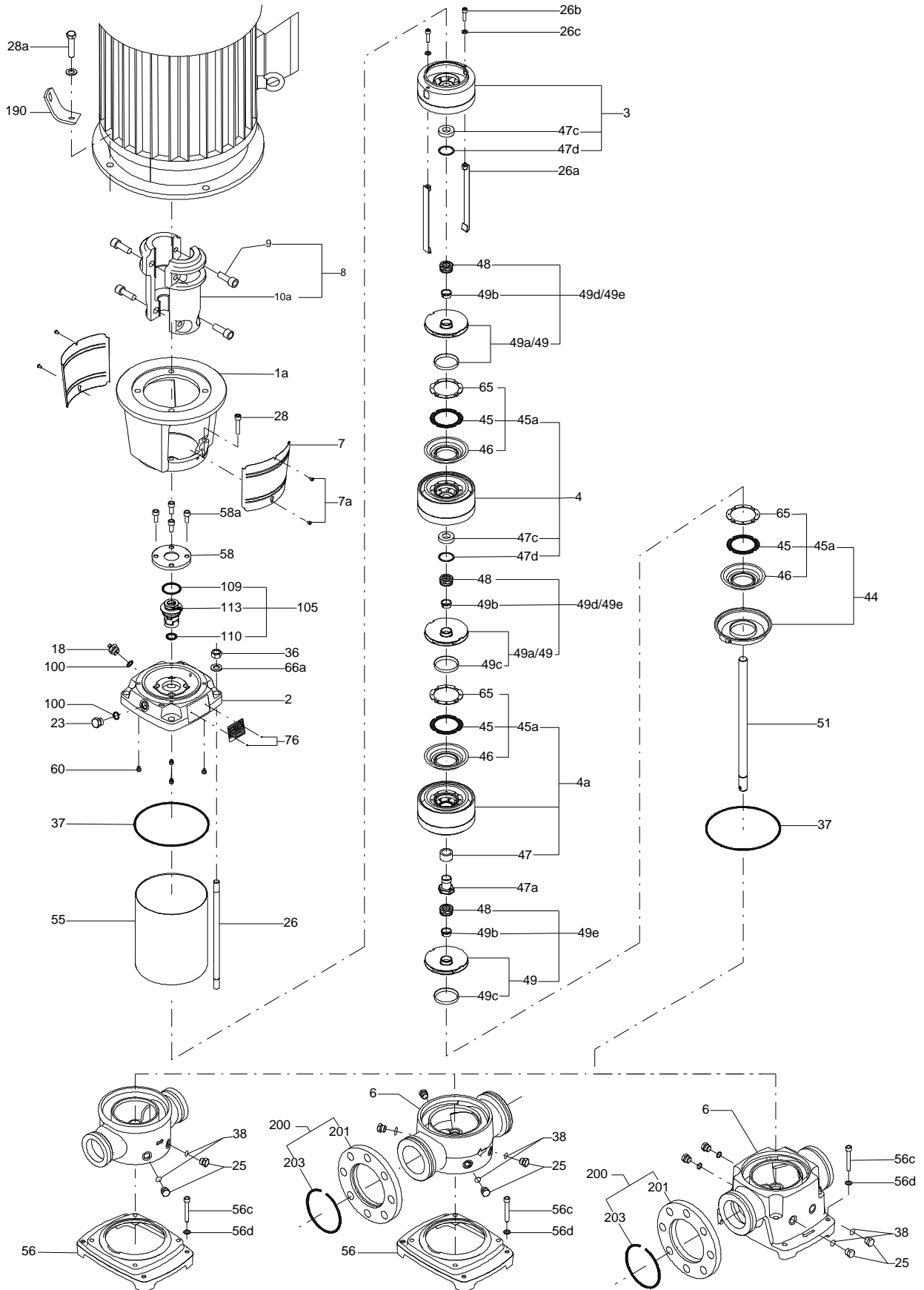

Sectional drawing ( TM065571 LACR)

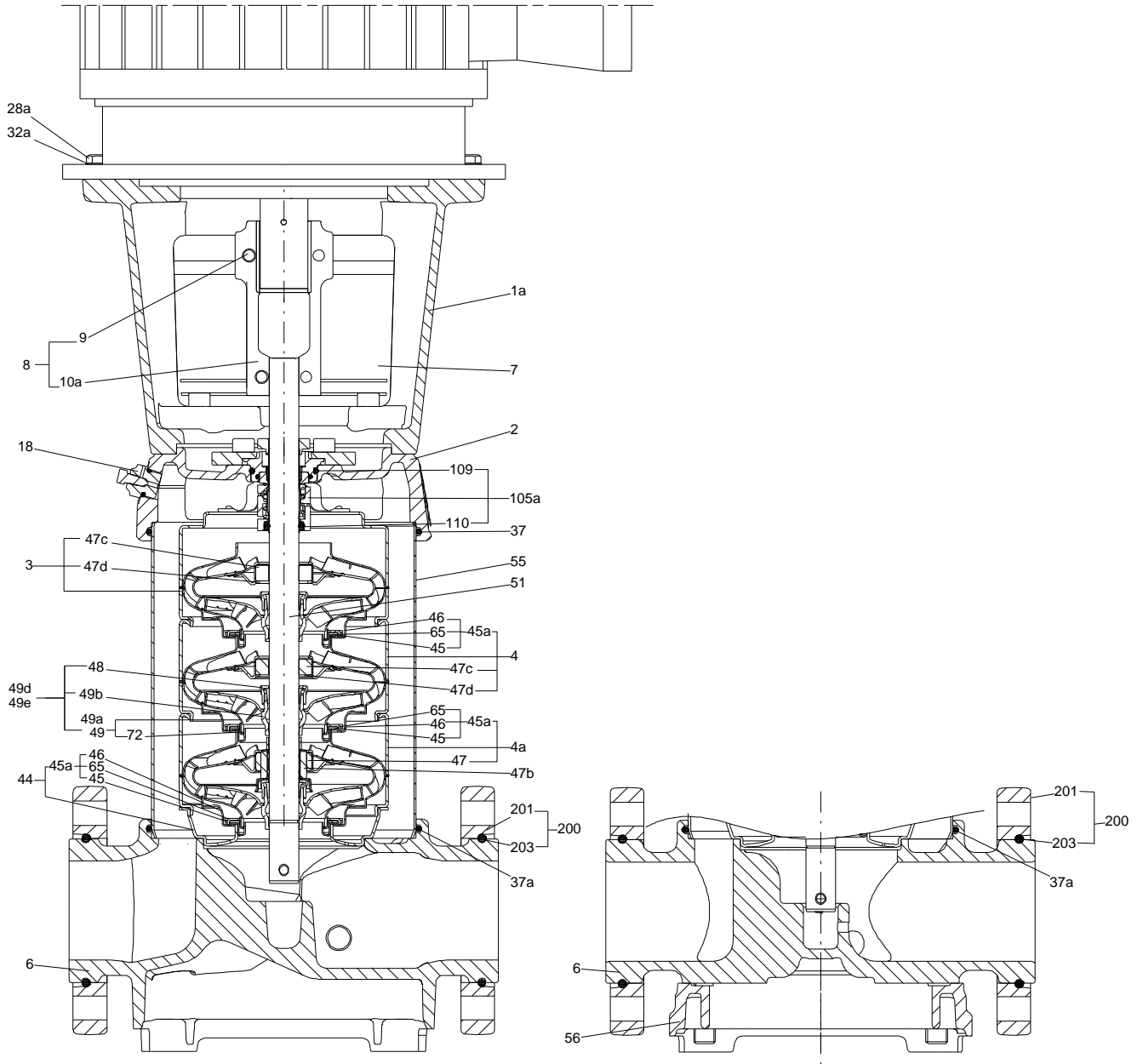

**Parts list CR 90-2-2, Prod number 96418784**  
**Valid from 3.3.2014 (1410)**

Position	Description	Annotation	Classification data	Part No.	Count	Unit
	Motor				1	pcs
-	Flange cpl.				2	pcs
201	Flange		Pressure (bar): 150-4 Dimension: 229X25		1	
203	Lock ring				1	
- 1	Basic unit				1	pcs
- 2a	Pump head cpl.				1	
2	Pump head					
9	Hex socket head cap screw		Designation: DIN 912 Length: 25 Thread: M10			
- 18	Air vent screw					
	Plug					
	Spindle					
23	Plug					
37	O-ring		Diameter: 255 Material type: FKM Thickness: 4,00			
58	Cover					
60	Spring					
100	O-ring		Diameter: 16,3 Material type: FKM Thickness: 2,4			
- 6b	Base cpl.		Rubber type: KFM		1	
6	Base					
25	Plug					
32	Washer		Designation: DIN 125A Inner diameter: 6,4 Outer diameter: 12,0 Thickness: 1,6			
37	O-ring		Diameter: 255 Material type: FKM Thickness: 4,00			
38	O-ring		Diameter: 16,3 Material type: FKM Thickness: 2,4			
26	Staybolt		Length: 356 Thread: M16		4	
36	Hex nut		Thread: M16		4	
55	Outer sleeve		Outer diameter: 225,0 Length: 207,5		1	
66a	Washer		Designation: DIN 125 A Inner diameter: 17 Outer diameter: 30 Thickness: 3		4	
- 80	Chamber stack				1	
- 3	Upper chamber cpl.					
	Chamber					
	Guide vane					
	Cone					
	Guide cup					
	Guide cup					
3	Chamber					

Position	Description	Annotation	Classification data	Part No.	Count	Unit
47c	Bush					
47d	Lock ring					
- 4a	Intermediate chamber cpl.					
	Chamber					
	Chamber					
	Neck ring cpl.					
	Guide vane					
	Cone					
	Guide cup					
	Guide cup					
47	Bearing					
26a	Strap cpl.		Length: 193 Thread: M8			
26b	Hex socket head cap screw					
26c	Washer		Designation: DIN 125A Inner diameter: 8,4 Outer diameter: 16 Thickness: 1,6			
- 44	Suction interconnector coupling					
44	Suction interconnector					
46	Neck ring cpl.					
47a	Bearing					
- 49	Impeller cpl.					
48	Nut					
49a	Impeller					
49b	Split cone					
- 49a	Impeller cpl. reduced diameter					
48	Nut					
- 49a	Impeller					
	Impeller hub					
49c	Wear ring					
49b	Split cone					
51	Shaft					
- 1a	Motor stool cpl.				1	pcs
1a	Motor stool				1	
7	Coupling guard				2	
7a	Socket button head screw				4	
28	Hex socket head cap screw		Designation: DIN 912 Length: 50 Thread: M10		4	
28a	Hex socket head cap screw		Length: 13 Thread: 1/2"		4	
- 8	Coupling cpl.		Dimension: 22/41,2		1	pcs
9	Hex socket head cap screw		Designation: DIN 912 Length: 25 Thread: M10		4	
10a	Coupling half				2	
- 105	Shaft seal		Material type: HQQV		1	pcs
	Adjusting fork				1	
109	O-ring		Diameter: 44,45 Material type: FKM Thickness: 3,53		1	
110	O-ring		Diameter: 21,5 Thickness: 4,25		1	