

# Unilift KP 150, KP 250, KP 350

Installation and operating instructions



## Original installation and operating instructions

## CONTENTS

	Page
<b>1. LIMITED WARRANTY</b>	<b>2</b>
<b>2. Symbols used in this document</b>	<b>3</b>
<b>3. General description</b>	<b>3</b>
3.1 Applications	3
3.2 Operating conditions	3
3.3 Sound pressure level	3
<b>4. Electrical connection</b>	<b>4</b>
<b>5. Installation</b>	<b>4</b>
5.1 Pipe connection	4
5.2 Basic requirements	4
5.3 Pump location and positioning	5
5.4 Adjustment of float switch	5
5.5 Non-return check valve	5
<b>6. Operation</b>	<b>6</b>
6.1 Starting	6
<b>7. Maintenance</b>	<b>6</b>
7.1 Cleaning the pump	6
7.2 Replacement of parts	7
<b>8. Fault finding chart</b>	<b>8</b>
<b>9. Disposal</b>	<b>8</b>

## Warning



Prior to installation, read these installation and operating instructions. Installation and operation must comply with local regulations and accepted codes of good practice.

**1. LIMITED WARRANTY**

Products manufactured by GRUNDFOS PUMPS CORPORATION (Grundfos) are warranted to the original user only to be free of defects in material and workmanship for a period of 24 months from date of installation, but not more than 30 months from date of manufacture. Grundfos' liability under this warranty shall be limited to repairing or replacing at Grundfos' option, without charge, F.O.B. Grundfos' factory or authorized service station, any product of Grundfos' manufacture. Grundfos will not be liable for any costs of removal, installation, transportation, or any other charges which may arise in connection with a warranty claim. Products which are sold but not manufactured by Grundfos are subject to the warranty provided by the manufacturer of said products and not by Grundfos' warranty. Grundfos will not be liable for damage or wear to products caused by abnormal operating conditions, accident, abuse, misuse, unauthorized alteration or repair, or if the product was not installed in accordance with Grundfos' printed installation and operating instructions.

To obtain service under this warranty, the defective product must be returned to the distributor or dealer of Grundfos' products from which it was purchased together with proof of purchase and installation date, failure date, and supporting installation data. Unless otherwise provided, the distributor or dealer will contact Grundfos or an authorized service station for instructions. Any defective product to be returned to Grundfos or a service station must be sent freight prepaid; documentation supporting the warranty claim and/or a Return Material Authorization must be included if so instructed.

**GRUNDFOS WILL NOT BE LIABLE FOR ANY INCIDENTAL OR CONSEQUENTIAL DAMAGES, LOSSES, OR EXPENSES ARISING FROM INSTALLATION, USE, OR ANY OTHER CAUSES. THERE ARE NO EXPRESS OR IMPLIED WARRANTIES, INCLUDING MERCHANTABILITY OR FITNESS FOR A PARTICULAR PURPOSE, WHICH EXTEND BEYOND THOSE WARRANTIES DESCRIBED OR REFERRED TO ABOVE.**

Some jurisdictions do not allow the exclusion or limitation of incidental or consequential damages and some jurisdictions do not allow limit actions on how long implied warranties may last. Therefore, the above limitations or exclusions may not apply to you. This warranty gives you specific legal rights and you may also have other rights which vary from jurisdiction to jurisdiction.

## 2. Symbols used in this document



### Warning

If these safety instructions are not observed, it may result in personal injury.



If these safety instructions are not observed, it may result in malfunction or damage to the equipment.



Notes or instructions that make the job easier and ensure safe operation.

## 3. General description

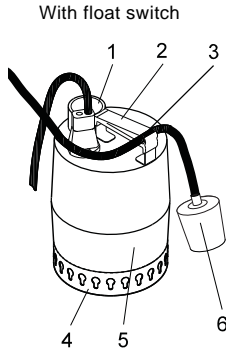

Fig. 1

1. Discharge port 1.25" NPT.
2. Handle.
3. Clamp.
4. Suction strainer.
5. Outer casing.
6. Float switch (optional).

### 3.1 Applications

The Grundfos Unilift KP 150, KP 250 and KP 350 pumps are single-stage submersible pumps designed for pumping grey water.



This pump has been evaluated for use with water, grey wastewater and heated wastewater.

The pump is capable of pumping water which contains a limited quantity of spherical solids up to 3/8" in diameter without being blocked or damaged. The pump is suitable for automatic (with float switch) as well as manual operation and can be installed in a permanent installation or used as a portable pump.

The pump is suitable for:

- Drainage of basements or buildings prone to flooding,
- Pumping of wastewater from washing machines, sinks, baths, showers, etc., up to the sewer level,
- Dewatering of sites or the pumping of water for fountains,
- Pumping in draining wells,
- Emptying swimming pools, ponds, tanks, or fountains.



### Warning

Do not use the pump in or at swimming pools, garden ponds, etc. when there are persons in the water.

The pump is **not** suitable for pumping:

- sewage
- liquids containing long fibers
- liquids containing solid particles larger than 3/8" in diameter
- flammable liquids (oil, gasoline, etc.)
- aggressive liquids.



If the pump has been used for very dirty or chlorinated water it should be flushed thoroughly with clean water after use.

The pump contains approx. 70 ml of non-poisonous motor liquid that may pollute the pumped liquid if the pump should leak.

TM03 4327 2006

### 3.2 Operating conditions

#### Liquid temperature

Minimum 32 °F. The maximum liquid temperature depends on the rated voltage of the pump, see the table below.

Voltage	Maximum liquid temperature
1 x 115 V, 60 Hz	+122 °F (+113 °F KP 350)

#### Storage temperature

Not lower than -4 °F.

#### Minimum water level

Water level must be above strainer inlet.

#### Maximum installation depth

30 feet below liquid level.

### 3.3 Sound pressure level

The sound pressure level of the pump is lower than the limiting values stated in the EC Council Directive 98/37/EC relating to machinery.

#### A-weighted sound pressure level

< 65 dB(A) in accordance with ISO 3743.

## 4. Electrical connection

The electrical connection should be carried out in accordance with local regulations and following the National Electrical Code. The pump should be grounded. The operating voltage and frequency are marked on the nameplate. Make sure that the motor is suitable for the electricity supply on which it will be used.

### Warning



The Unilift KP pumps have built-in thermal overload protection and require no additional motor protection. If the motor is overloaded, it will stop automatically. When it has cooled to normal temperature it will start automatically.

When connecting the pump for manual operation, the 115 V plug is inserted into a 115 V outlet. If a float switch is included for automatic operation it will be of the "Piggy-back" design. Plug the 115 V plug on the float switch into the 115 V outlet, and plug the 115 V plug from the pump into the float switch plug.

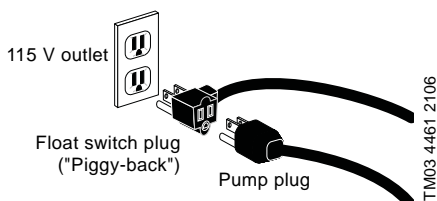

Fig. 2

### Warning



As a precaution, the pump must be connected to a socket with earth connection.

It is recommended to fit the permanent installation with a ground fault circuit interrupter (GFCI) with a tripping current < 30 mA.

## 5. Installation

### 5.1 Pipe connection

Steel or rigid plastic pipe can be screwed directly into the 1.25" NPT discharge port. For permanent installation, it is recommended to fit a union, a non-return valve and an isolating valve in the discharge pipe.

Other recommendations:

- For portable or temporary installations, plastic discharge pipe can be used in conjunction with a suitable screwed/hose connector.
- Removal of the pump should be by a cable secured to the pump handle and not by the discharge pipework.
- Screwed threads should be sealed using Teflon® tape.

**Note** The pump must not be installed hanging from the discharge pipe.

### 5.2 Basic requirements

When the pump is installed in a permanent installation with a float switch, and the cable length is set to the minimum length of at least 2.5" inches, the minimum dimensions of the well should be as shown in fig. 3.

Furthermore, the well should be sized according to the relation between the water flow to the well and the pump capacity.

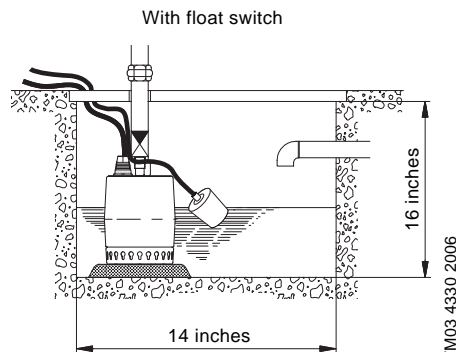

Fig. 3

### 5.3 Pump location and positioning

Pumps without or with float switch can be used in vertical position with the discharge port uppermost or in horizontal or tilted position with the discharge port as the highest point of the pump. See fig. 4.

When used in horizontal position, the pump must be completely covered by liquid.

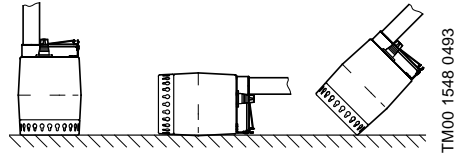

Fig. 4

When the pipe/hose has been connected, the pump is ready for use.

**Note** Do not lift the pump by means of the electric cable. Lift the pump by means of a cable secured to the handle of the pump.

Before positioning the pump, make sure that the suction strainer will not be blocked or partly blocked by silt, mud or similar materials.

This can be avoided by positioning the pump on bricks, an iron plate, etc. See fig. 5.

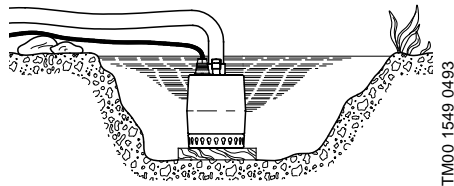

Fig. 5

### 5.4 Adjustment of float switch

The float switch can automatically turn the pump on and off. Switching the adjustment is possible by repositioning the float switch in the handle of the pump.

The free cable length must always be:

- at least 2.5 inches
- no more than 6 inches.

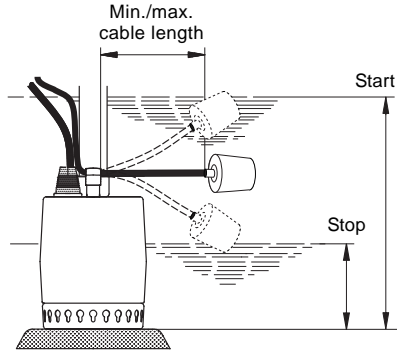

Fig. 6

The start/stop level varies according to the cable length.

	Cable length Min. 2.5"		Cable length Max. 6"	
	Start	Stop	Start	Stop
Unilift KP 150	11.5"	5.5"	12,5"	3.5"
Unilift KP 250				
Unilift KP 350	12"	6"	13"	4"

For manual operation, unplug both the pump and float switch from the 115 V outlet. Plug the 115 V plug on the pump into the outlet.

### 5.5 Non-return check valve

Whenever the pump is installed in a permanent installation with a float switch, a non return valve must be fitted in the discharge pipe or hose.

## 6. Operation

### 6.1 Starting

Before starting the pump, check:

- whether the pump is submerged in liquid. During normal operation, the strainer of the pump must be below the surface of the liquid
- whether the pump is positioned on a base so that the strainer is not blocked by silt, mud or similar materials
- whether the pipe/hose connection is tight
- whether the discharge pipe is open (bend of hose, etc.)
- whether the pump is connected to the electric supply in accordance with the instructions
- check the float switch for free movement.

After start-up, check that:

- the pump operates properly, that water is being pumped, and the pump operates through the control sequence
- the float switch will allow the pump to pump down to a level of approximately 4". To pump out below this level secure the switch in the manual position. See section [5.4 Adjustment of float switch](#).



#### Warning

As a precaution, the suction strainer must always be fitted to the pump during operation.

## 7. Maintenance

Under normal operating conditions, the pump is maintenance-free.

If the pump has been used for liquids other than clean water, it should be flushed through with clean water immediately after use.

### 7.1 Cleaning the pump



#### Warning

Never dismantle the pump unless the electricity supply has been switched off. During dismantling, caution should be exercised as there will be access to sharp edges, etc. which may cut.

If the pump does not deliver a sufficient quantity of water because of sediment, dismantle and clean the pump.

The dismantling of the pump is carried out as follows:

1. Disconnect the electricity supply.
2. Allow the pump to drain.
3. Carefully loosen the suction strainer by inserting a screwdriver in the recess between the outer casing and the strainer and pressing it hard. Repeat the procedure until the strainer is free and can be removed, see fig. 7.

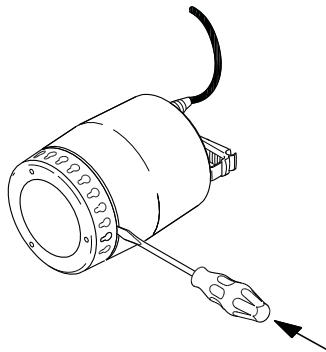

Fig. 7

4. Clean the suction strainer and refit it.

If the pump still does not deliver a sufficient quantity of water, dismantle the pump as follows:

1. Disconnect the electricity supply.
2. Turn the pump housing 90 ° counter-clockwise using a screwdriver, see the arrow on the pump housing. Pull off the housing, see fig. 8.

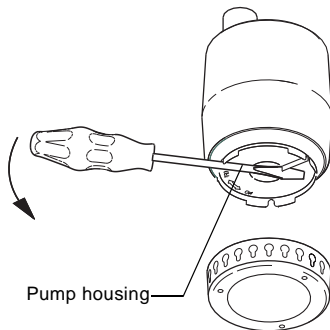
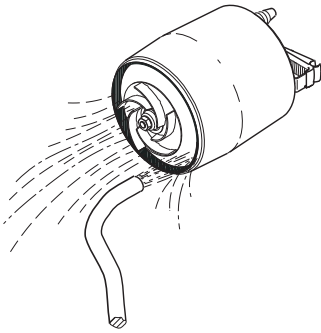

Fig. 8

3. Clean and flush the pump with water to remove possible impurities between the motor and the outer casing. Clean the impeller, see fig. 9.



TM03 1169 1205

Fig. 9

4. Check that the impeller can rotate freely. If not, remove the impeller:
  - Slacken and remove the nut on the motor shaft (13 mm). Prevent the impeller from rotating by means of a screwdriver, see fig. 10.
  - Clean the impeller and around the shaft.

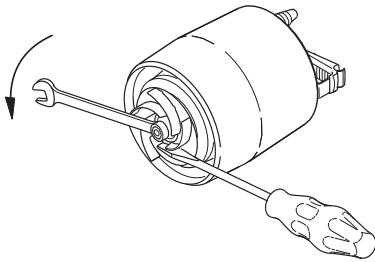

TM03 1170 1205

Fig. 10

5. Check the impeller, the pump housing and the sealing part. Replace possible defective parts.
6. Assemble the pump in reverse order of dismantling.

**Note**

Check before and when fitting the pump housing that the sealing part is positioned correctly, see fig. 11. Moisten the sealing part with water to facilitate the fitting.

## 7.2 Replacement of parts

The impeller assembly and electric cord can be replaced.

The part numbers and the components included in the service kits will appear from the tables below and fig. 11.

Pump type	Part number	
<b>Impeller kit</b>		
KP 150, 60 Hz	015783	
KP 250, 60 Hz	015784	
KP 350, 60 Hz	015786	
<b>Replacement cords</b>		
10' 60 HZ	016728	
25' 60 HZ	016729	

Service kit	Description	Qty.
Impeller kit	Impeller	1
	Nut	1
	Gasket	1

If pump components other than those mentioned above are damaged or defective, please contact your pump supplier.

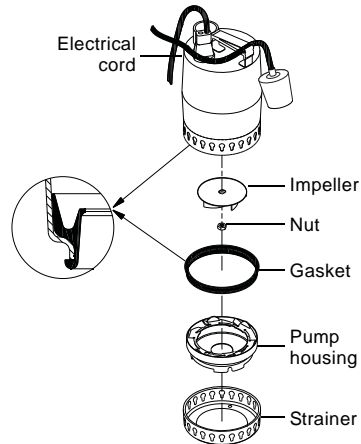

Fig. 11

TM03 4328 2006

## 8. Fault finding chart

Fault	Cause
1. Motor does not start.	a) Supply failure. b) Pump switched off by float switch/vertical level switch. c) Fuses are blown. d) Thermal relay has cut out the electricity supply to the motor (see section <a href="#">4. Electrical connection</a> ). e) Check cable for defects.
2. Thermal relay trips out after short time of operation.	a) Temperature of pumped liquid higher than that stated in section <a href="#">3.2 Operating conditions</a> . b) Pump partly blocked by impurities (see section <a href="#">6. Operation</a> ). c) Pump mechanically blocked (see section <a href="#">6. Operation</a> ). d) Check volts and amperage. e) Check cable for defects.
3. Pump runs but gives insufficient water.	a) Pump partly blocked by impurities (see section <a href="#">6. Operation</a> ). b) Discharge pipe/hose partly blocked. Check the non-return valve, if fitted. c) Check the impeller, the pump housing and the sealing part (see section <a href="#">6. Operation</a> ).
4. Pump runs but gives no water.	a) Pump blocked by impurities (see section <a href="#">6. Operation</a> ). b) Non-return valve, if fitted, in discharge pipe/hose blocked in closed position. c) Liquid level is too low. During normal operation, the liquid level must be above the strainer. d) Pumps with float switch: The free cable of the float switch is too long (see section <a href="#">5.4 Adjustment of float switch</a> ).

## 9. Disposal

This product or parts of it must be disposed of in an environmentally sound way:

1. Use the public or private waste collection service.
2. If this is not possible, contact the nearest Grundfos company or service workshop.

---

Subject to alterations.



**GRUNDFOS Kansas City**

17100 West 118th Terrace  
Olathe, Kansas 66061  
Phone: (913) 227-3400  
Fax: (913) 227-3500

[www.grundfos.us](http://www.grundfos.us)

**GRUNDFOS Canada**

2941 Brighton Road  
Oakville, Ontario L6H 6C9 Canada  
Phone: +1-905 829 9533  
Telefax: +1-905 829 9512

[www.grundfos.ca](http://www.grundfos.ca)

**GRUNDFOS México**

Boulevard TLC No. 15  
Parque Industrial Stiva Aeropuerto  
C.P. 66600 Apodaca, N.L. México  
Phone: 011-52-81-8144 4000  
Fax: 011-52-81-8144 4010

[www.grundfos.mx](http://www.grundfos.mx)

<b>96637677</b> 0117
----------------------

ECM: 1199725
--------------

The name Grundfos, the Grundfos logo, and **be think innovate** are registered trademarks owned by Grundfos Holding A/S or Grundfos A/S, Denmark. All rights reserved worldwide.

© Copyright Grundfos Holding A/S