

**The Timken Company**

4500 Mt Pleasant St. NW

N. Canton, OH 44720

**Phone:** (234) 262-3000

**E-Mail:** [CustomerCAD@timken.com](mailto:CustomerCAD@timken.com) • **Web site:** [www.timken.com](http://www.timken.com)
**Part Number 230/530KYMBW507C08, Spherical Roller Bearings - Brass Cage**

Spherical bearings are designed to manage high radial loads even when misalignment, poor lubrication, contamination, extreme speeds or critical application stresses are present.

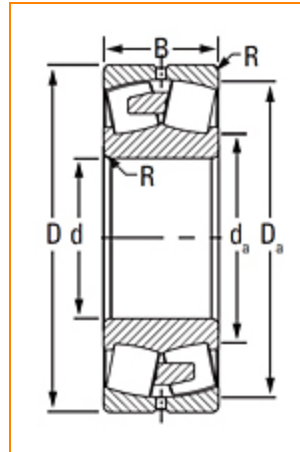

[Specifications](#) | [Dimensions](#) | [Abutment and Fillet Dimensions](#) | [Basic Load Ratings](#) | [Factors](#)

**Specifications**

<b>Design Unit</b>	Metric
<b>d - Bore</b>	530 mm
<b>Bore_Taper</b>	1/12
<b>Cage Type</b>	YMB
<b>Cage Material</b>	Brass

**Dimensions**

<b>D - Outer Diameter</b>	780 mm 30.709 in
 <b>- Inner Ring Width</b>	185 mm 7.284 in

<b>B - Outer Ring Width</b>	185 mm 7.2840 in
-----------------------------	---------------------

## Abutment and Fillet Dimensions

<b>R - Inner Ring "To Clear" Radius<sup>1</sup></b>	5 mm 0.200 in
---	------------------

<b>r - Outer Ring "To Clear" Radius<sup>2</sup></b>	5 mm 0.2 in
---	----------------

<b>da - Inner Ring Backing Diameter</b>	588.000 mm 23.2000 in
---	--------------------------

<b>Da - Outer Ring Backing Diameter</b>	725.000 mm 28.600 in
---	-------------------------

## Basic Load Ratings

<b>C0 - Static Radial Rating</b>	9720000 N 2190000 lbf
----------------------------------	--------------------------

<b>C1(2) - Dynamic Radial Rating (Two-Rows)</b>	5150000 N 1160000 lbf
---	--------------------------

## Factors

<b>e - ISO Factor<sup>3</sup></b>	0.21
-----------------------------------	------

<b>Y0 - ISO Factor<sup>4</sup></b>	3.07
------------------------------------	------

<b>Y1 - ISO Factor<sup>5</sup></b>	3.14
------------------------------------	------

<b>Y2 - ISO Factor<sup>6</sup></b>	4.68
------------------------------------	------

<b>Reference Thermal Speed Rating (Grease)</b>	460 rpm
--	---------

<b>Reference Thermal Speed Rating (Oil)<sup>7</sup></b>	530 rpm
---	---------

<b>Cg - Geometry Factor<sup>8</sup></b>	0.1083
---	--------

<sup>1</sup> Maximum housing fillet radius that bearing corners will clear.

<sup>2</sup> Maximum shaft fillet radius that bearing corners will clear.

<sup>3</sup> These factors apply for both inch and metric calculations. Consult your Timken representative for instruction on use.

<sup>4</sup> These factors apply for both inch and metric calculations. See engineering

<sup>5</sup> These factors apply for both inch and metric calculations. Consult your Timken representative for instruction on use.

<sup>6</sup> These factors apply for both inch and metric calculations. Consult your Timken representative for instruction on use.

<sup>7</sup> See thermal speed ratings in the engineering section.

<sup>8</sup> Geometry constant for Lubrication Life Adjustment Factor a3l.

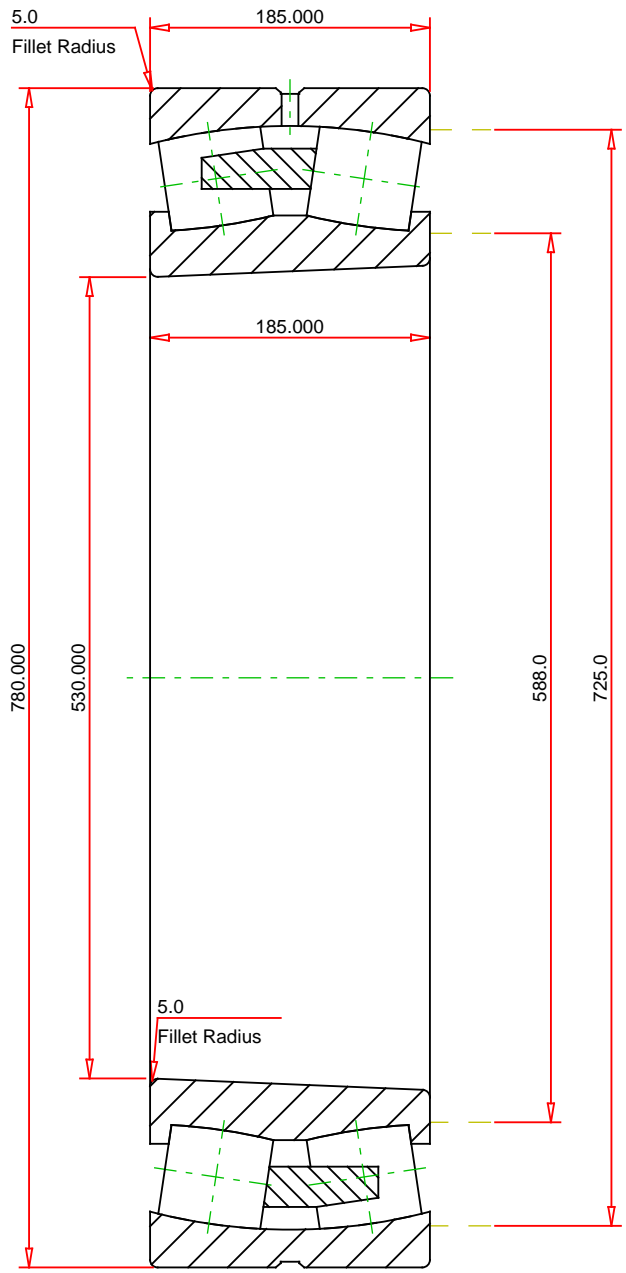

METRIC UNITS

Number of Rollers Per Row	28
ISO Factor e	0.21
ISO Factor Y0	3.07
ISO Factor Y1	3.14
ISO Factor Y2	4.68
Bearing Weight	302.6 kg
Cage Type	YMB
Cage Material	Brass
Bore Taper	1/12



**THE TIMKEN COMPANY**  
NORTH CANTON, OHIO USA

**230/530KYMBW507C08**  
SRB ASSEMBLY

Dynamic Radial Rating (Two Rows)	5150000	N
Static Radial Rating	9720000	N

Every reasonable effort has been made to ensure the accuracy of the information contained in this writing, but no liability is accepted for errors, omissions or for any other reason.

**FOR DISCUSSION ONLY**