



The Timken Company

4500 Mt Pleasant St. NW

N. Canton, OH 44720

Phone: (234) 262-3000

E-Mail: CustomerCAD@timken.com • **Web site:** www.timken.com

Part Number ER27, Fafnir® Wide Inner Ring Setscrew Locking Ball Bearings

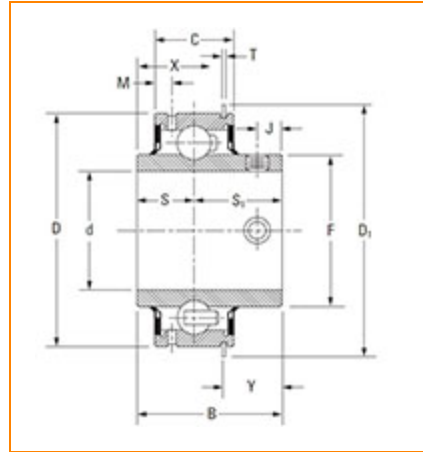

[Specifications](#) | [Dimensions](#) | [Basic Load Ratings](#)

Specifications

Series	Industrial
Shaft Size d	1 11/16 in
Bore Type	Cylindrical bore
Bearing Type	Ball Bearing
Material	Bearing Steel
Lubrication Type	Relubricatable
O.D. Type	Cylindrical OD
Sub Series	ER
Seal Type	Narrow Shroud
Basic Outer Ring Size	209



Dimensions

Outside Diameter D	3.346 in 85 mm
Inner Ring Width B	1.984 in 50.37 mm
Outside Ring Width C	1.094 in 27.72 mm
Radius r	0.024 in 0.6 mm
Center of Bearing from End S	0.75 in 19.05 mm
Dimension S1	1.234 in 31.32 mm
Dimension F	2.234 in 57.9 mm
Dimension J	0.359 in 9.14 mm
Dimension M	0.25 in 6.33 mm
Dimension D1	3.578 in 91.11 mm
Dimension T	0.063 in 1.65 mm
Dimension X	1.109 in 28.12 mm
Dimension Y	0.875 in 22.25 mm
Set Screw Size	M8x1.25
Number of Set Screws	2
Angle between Set Screws	90 °

Basic Load Ratings

Static Load Rating	4600 lbf 20424 N
Dynamic Load Rating	8160 lbf 36230.4 N

