

The Timken Company

4500 Mt Pleasant St. NW

N. Canton, OH 44720

Phone: (234) 262-3000

E-Mail: CustomerCAD@timken.com • **Web site:** www.timken.com

Part Number SAF 23048K 9, Inch Tapered Bore Mounting Pillow Block SAF230K and SDAF230K Series

- Each assembly includes the housing cap and base, cap bolts, bearing, bearing adapter, locknut and lockwasher, stabilizing ring and triple ring seals.
- If only the pillow block is desired, use the numbers listed in column "Housing Only" column. These units include: cap, base, cap bolts, triple ring seals and stabilizing ring.
- Assembly and pillow blocks as described on this page constitute fixed units.
- To order float units, specify part number plus suffix "Float" or "FL".
- If one end closed

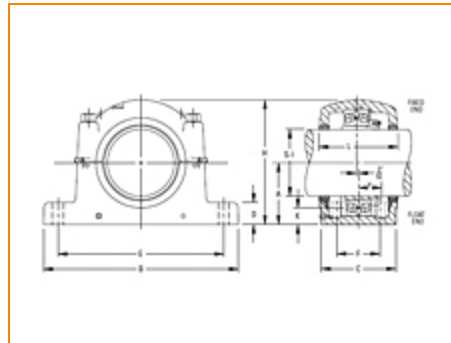
[more](#)

[Specifications](#) | [Basic Load Ratings](#) | [Factors](#)

Specifications

Bearing Number	23048K
Diameter S-1	9.0000 in
A	8-1/4 in
B	29.5 in
C	8 in



D	3.375 in
E Max.	25 in
E Min.	22.5 in
F	5 in
H	17.1875 in
L	11.125 in
Bolt Hole Length	2.5 in
Bolt Hole Width	1.25 in
No. of Base Bolts Required	4
Adapter Assembly Number¹	SNP-3048 x 9.000
Housing Only²	SAF048K-9
Stabilizing Ring 1 Req'd³	A8897
Triple Seal Req'd	LOR 530
Seal Type	Triple Ring Seal
Full Timken Part Number	SAF23048K9

Basic Load Ratings

C0 - Static Radial Rating	480000 lbf 2140000 N
C1(2) - Dynamic Radial Rating (Two-Rows)	315000 lbf 1400000 N

Factors

e - ISO Factor⁴	0.23
-----------------------------------	------

Y0 - ISO Factor⁵	2.85
Y1 - ISO Factor⁶	2.91
Y2 - ISO Factor⁷	4.34
Reference Thermal Speed Rating (Grease)	1300 rpm
Reference Thermal Speed Rating (Oil)⁸	1500 rpm
Cg - Geometry Factor⁹	0.1059

¹ Includes sleeve, locknut and lockwasher. Add shaft size to order.

² "Housing Only" includes: cap, base, cap bolts, triple ring seals and stabilizing ring as required. When ordering non-standard housing only specify the shaft size.

³ Stabilizing ring is used for fixed (FX) block; do not use for float (FL) mounting.

⁴ These factors apply for both inch and metric calculations. Consult your Timken representative for instruction on use.

⁵ These factors apply for both inch and metric calculations. See engineering

⁶ These factors apply for both inch and metric calculations. Consult your Timken representative for instruction on use.

⁷ These factors apply for both inch and metric calculations. Consult your Timken representative for instruction on use.

⁸ See thermal speed ratings in the engineering section.

⁹ Geometry constant for Lubrication Life Adjustment Factor a3l.

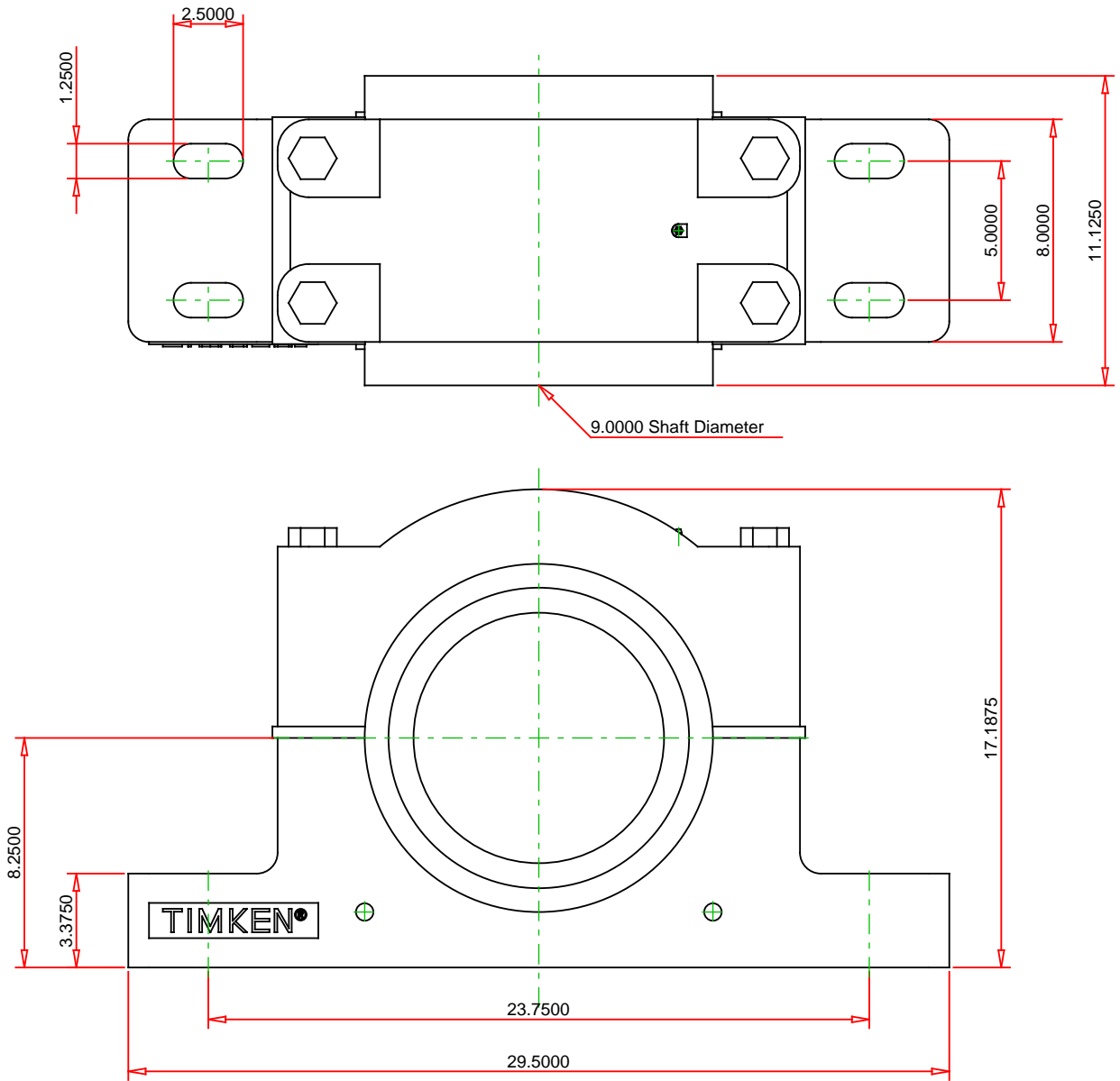

IMPERIAL UNITS

Housing	SAF048K-9
Bearing	23048K
Seal Type	LOR 530
Adapter Sleeve	SNP-3048 x 9.000
(includes 1 sleeve, 1 locknut and 1 lockwasher)	
Stabilizing Ring	A8897
Bolt Hole Spacing Max.	25.0000
Bolt Hole Spacing Min.	22.5000

TIMKEN®

THE TIMKEN COMPANY
NORTH CANTON, OHIO USA

SAF 23048K 9
PILLOW BLOCK SAF230 AND SDAF230

Every reasonable effort has been made to ensure the accuracy of the information contained in this writing, but no liability is accepted for errors, omissions or for any other reason.

FOR DISCUSSION ONLY