

**The Timken Company**

4500 Mt Pleasant St. NW

N. Canton, OH 44720

**Phone:** (234) 262-3000

**E-Mail:** [CustomerCAD@timken.com](mailto:CustomerCAD@timken.com) • **Web site:** [www.timken.com](http://www.timken.com)

## Part Number SAF 23048K 8-1/2, Inch Tapered Bore Mounting Pillow Block SAF230K and SDAF230K Series

- Each assembly includes the housing cap and base, cap bolts, bearing, bearing adapter, locknut and lockwasher, stabilizing ring and triple ring seals.
- If only the pillow block is desired, use the numbers listed in column "Housing Only" column. These units include: cap, base, cap bolts, triple ring seals and stabilizing ring.
- Assembly and pillow blocks as described on this page constitute fixed units.
- To order float units, specify part number plus suffix "Float" or "FL".
- If one end closed

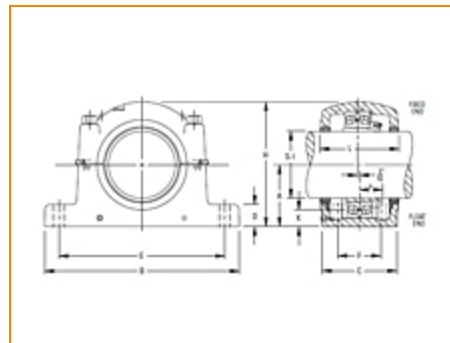
[more](#)

[Specifications](#) | [Basic Load Ratings](#) | [Factors](#)

### Specifications

<b>Bearing Number</b>	23048K
<b>Diameter S-1</b>	8.5000 in
<b>A</b>	8-1/4 in
<b>B</b>	29.5 in
<b>C</b>	8 in



<b>D</b>	3.375 in
<b>E Max.</b>	25 in
<b>E Min.</b>	22.5 in
<b>F</b>	5 in
<b>H</b>	17.1875 in
<b>L</b>	11.125 in
<b>Bolt Hole Length</b>	2.5 in
<b>Bolt Hole Width</b>	1.25 in
<b>No. of Base Bolts Required</b>	4
<b>Adapter Assembly Number<sup>1</sup></b>	SNP-3048 x 8-1/2
<b>Housing Only<sup>2</sup></b>	SAF048K-8 1/2
<b>Stabilizing Ring 1 Req'd<sup>3</sup></b>	A8897
<b>Triple Seal Req'd</b>	LOR 527
<b>Seal Type</b>	Triple Ring Seal
<b>Full Timken Part Number</b>	SAF23048K8-1/2

## Basic Load Ratings

<b>C0 - Static Radial Rating</b>	480000 lbf 2140000 N
<b>C1(2) - Dynamic Radial Rating (Two-Rows)</b>	315000 lbf 1400000 N

## Factors

<b>e - ISO Factor<sup>4</sup></b>	0.23
-----------------------------------	------

<b>Y0 - ISO Factor<sup>5</sup></b>	2.85
<b>Y1 - ISO Factor<sup>6</sup></b>	2.91
<b>Y2 - ISO Factor<sup>7</sup></b>	4.34
<b>Reference Thermal Speed Rating (Grease)</b>	1300 rpm
<b>Reference Thermal Speed Rating (Oil)<sup>8</sup></b>	1500 rpm
<b>Cg - Geometry Factor<sup>9</sup></b>	0.1059

<sup>1</sup> Includes sleeve, locknut and lockwasher. Add shaft size to order.

<sup>2</sup> "Housing Only" includes: cap, base, cap bolts, triple ring seals and stabilizing ring as required. When ordering non-standard housing only specify the shaft size.

<sup>3</sup> Stabilizing ring is used for fixed (FX) block; do not use for float (FL) mounting.

<sup>4</sup> These factors apply for both inch and metric calculations. Consult your Timken representative for instruction on use.

<sup>5</sup> These factors apply for both inch and metric calculations. See engineering

<sup>6</sup> These factors apply for both inch and metric calculations. Consult your Timken representative for instruction on use.

<sup>7</sup> These factors apply for both inch and metric calculations. Consult your Timken representative for instruction on use.

<sup>8</sup> See thermal speed ratings in the engineering section.

<sup>9</sup> Geometry constant for Lubrication Life Adjustment Factor a3l.

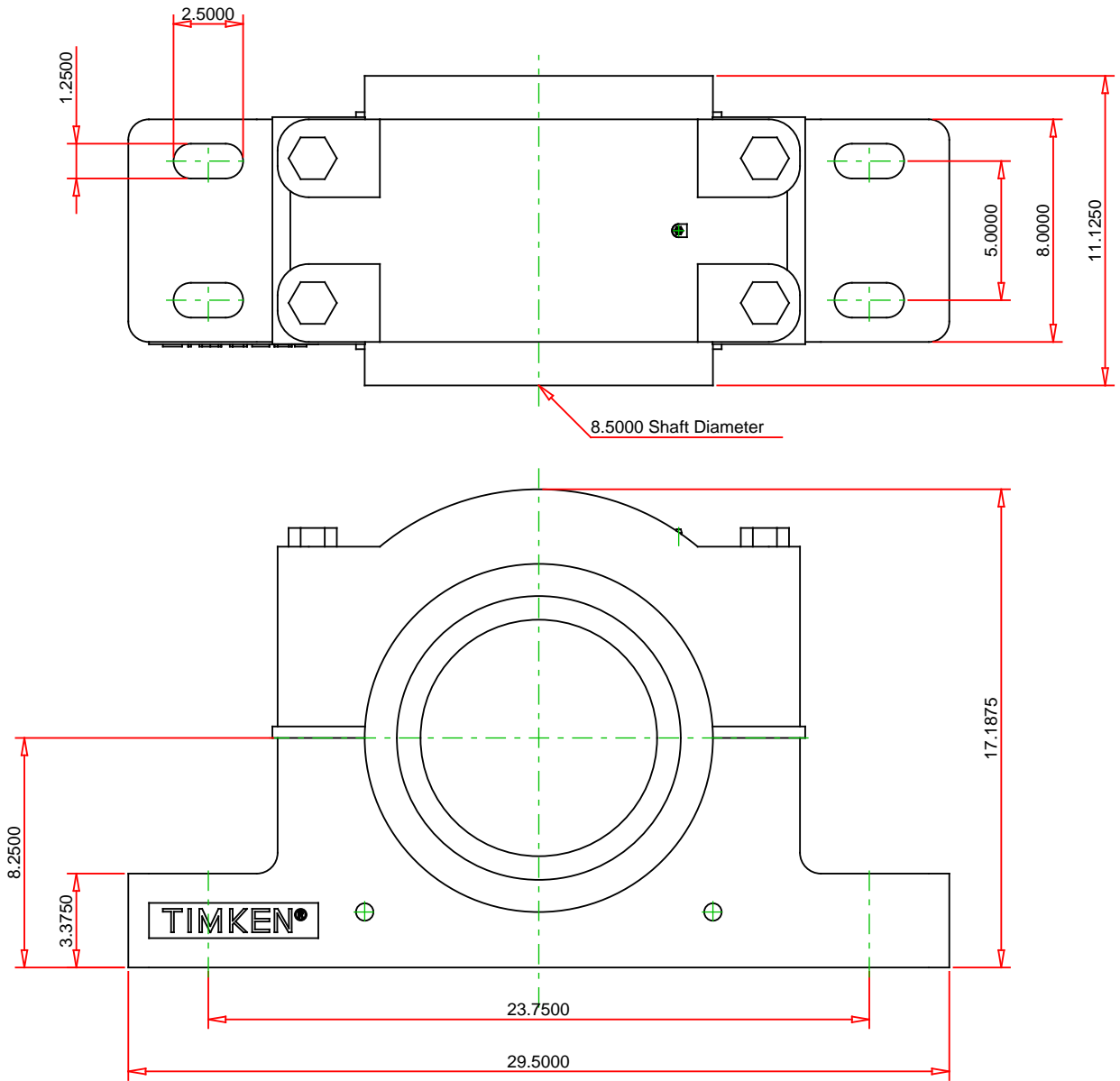

IMPERIAL UNITS

Housing	SAF048K-8 1/2
Bearing	23048K
Seal Type	LOR 527
Adapter Sleeve	SNP-3048 x 8-1/2
(includes 1 sleeve, 1 locknut and 1 lockwasher)	
Stabilizing Ring	A8897
Bolt Hole Spacing Max.	25.0000
Bolt Hole Spacing Min.	22.5000

**TIMKEN**®

**THE TIMKEN COMPANY**  
NORTH CANTON, OHIO USA

**SAF 23048K 8-1/2**  
PILLOW BLOCK SAF230 AND SDAF230

Every reasonable effort has been made to ensure the accuracy of the information contained in this writing, but no liability is accepted for errors, omissions or for any other reason.

**FOR DISCUSSION ONLY**