

**The Timken Company**

4500 Mt Pleasant St. NW

N. Canton, OH 44720

**Phone:** (234) 262-3000

**E-Mail:** [CustomerCAD@timken.com](mailto:CustomerCAD@timken.com) • **Web site:** [www.timken.com](http://www.timken.com)

## Part Number 340RYL1963, Cylindrical Roller Radial Bearings - Four-Row

Timken's four-row cylindrical roller bearings are designed for the rigors of daily use in applications where moderate and high speeds, high radial loads, elevated temperatures and debris are constant challenges. Designed with well-balanced cross sections, these bearings provide high-radial-load capacity within the bearing envelope.

The radial internal clearance (RIC) for the bearing assembly must be included when ordering either a) the complete assembly or b) with the inner-ring set. It is [more](#)

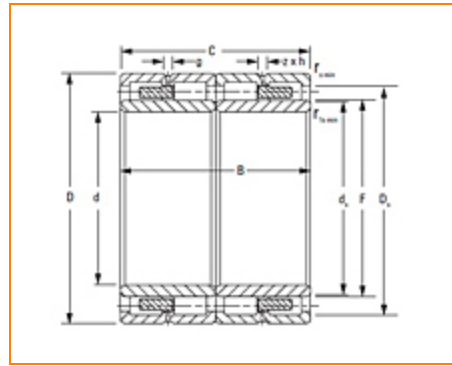

[Specifications](#) | [Bearing Dimensions](#) | [Mounting Data](#) | [Lubrication Data](#) | [Sub Assembly Part Numbers](#) | [Applications](#) | [Design Benefits](#) | [Radial Internal Clearance \(RIC\)](#) | [Lubrication](#) | [Material](#) | [Mounting Design and Fitting Practice](#) | [Main Design Types](#)

### Specifications

|   |                           |
|---|---------------------------|
| <b>Bore d</b>   | 340.000 mm                |
| <b>Static Load Rating <math>C_0</math></b>              | 10880000 N<br>2444000 lbf |
| <b>Dynamic Load Rating <math>C_1</math><sup>1</sup></b> | 5180000 N<br>1162000 lbf  |

### Bearing Dimensions



|                    |                      |
|--------------------|----------------------|
| <b>O.D. D</b>      | 480 mm<br>18.8976 in |
| <b>Width B</b>     | 350 mm<br>13.7795 in |
| <b>Width C</b>     | 350 mm<br>13.7795 in |
| <b>DUR/DOR F/E</b> | 378 mm<br>14.8819 in |
| <b>Type</b>        | RY-3                 |

### Mounting Data

|  |                        |
|--|------------------------|
| <b>Chamfer <math>r_{smin}</math></b>             | 3 mm<br>0.12 in        |
| <b>Chamfer <math>r_{1smin}^2</math></b>          | 8 mm<br>0.320 in       |
| <b>Angle of Chamfer <math>r_{1smin}</math></b>   | 20°                    |
| <b>Backing Shaft Diameter <math>d_s</math></b>   | 370.6 mm<br>14.5900 in |
| <b>Backing Housing Diameter <math>D_s</math></b> | 446 mm<br>17.5600 in   |

### Lubrication Data

|   |              |
|---|--------------|
| <b>Lubrication Groove <math>g</math></b>        | 0 mm<br>0 in |
| <b>Lubrication Hole Diameter <math>h</math></b> | 0 mm<br>0 in |
| <b>Number of Lubrication Holes</b>              | 0            |

### Sub Assembly Part Numbers

|                       |              |
|-----------------------|--------------|
| <b>Inner-Ring Set</b> | 340ARYSL1963 |
|-----------------------|--------------|

|                       |             |
|-----------------------|-------------|
| <b>Outer-Ring Set</b> | 378RYSL1963 |
|-----------------------|-------------|

## Applications

Engineered primarily for rolling mill roll-neck applications, Timken's four-row cylindrical bearings are commonly used in work roll or back-up roll positions in flat product, long product and structural mills.

### Product Features

- Available in sizes 140 mm I.D. – 2000 mm O.D. (5.512 in – 78.740 in).
- Case-hardened rings and rollers enhance durability.
- Inner races are interchangeable with outer assemblies.
- Manufactured to P6 boundary and P5 run out tolerances.
- Roller profiles are custom designed and manufactured for optimum performance.
- Straight and tapered bores are available.

## Design Benefits

Our most common configurations available are types RY, RYL and RX. However, Timken also will custom design and manufacture bearings for your particular size and application requirements. If you have a new mill application, our engineers will work with you in the earliest design stages to help you select the right bearings.

## Radial Internal Clearance (RIC)

Timken's standard bearings offer different clearances, such as C3 or C4 according to DIN 620-4. If needed for your application, they can be furnished with a tapered bore.

Timken supplies inner rings in two ways: a finished state with no additional grinding required or a semi-

finished condition with appropriate grind stock. Semi-finished inner rings allow mill operators to optimize the roll's precision by finish grinding the inner ring after mounting it onto the roll.

The part numbers for these bearings and inner-ring assemblies are identified by a CF suffix.

## Lubrication

Timken four-row cylindrical roller bearings can be used with grease, oil-air, oil-mist or circulating-oil systems. The bearings must be correctly lubricated for maximum performance through either lubrication grooves, holes in the outer-ring O.D. or through integrated face slots on the outer-ring faces. See detailed design types on pages 84-87 for further information on the standard lubrication configurations by bearing type.

## Material

Our bearings are designed to provide superior size stability, fracture toughness and reliability. By using only high quality, carburized alloy, and applying a special heat-treatment during the manufacturing process, we are able to produce bearings that can withstand the heavy stresses and impact loading often experienced by multi-row cylindrical roller bearings used in rolling mills.

## Mounting Design and Fitting Practice

The cylindrical roller bearing design accommodates radial loading only, therefore, a separate thrust bearing must be used to provide axial shaft location.

The housing fitting practice usually results in a loose fit to facilitate easy removal at regular maintenance intervals. The preferred shaft fit is tight. There are occasions where loose shaft fits are tolerated, such as on some roughing-mill equipment. In the cases where a shaft fit is loose, inner-race bore lubrication grooves must be incorporated in the bearing. Check with your Timken representative for a more details on mounting four-row cylindrical roller bearings. Mounting information also is available in the Timken Engineering Manual (order no. 10424) on [timken.com/catalogs](http://timken.com/catalogs).

In order to facilitate the dismounting, face slots can be added on the inner rings (W30B modification code).

Inner rings can be ordered separately from the outer assembly in order to equip additional spare rolls. Inner- and outer ring assemblies are interchangeable in regard to internal clearance.

## Main Design Types

Optimized rolling elements and race geometry provides high radial-load capacity within the bearing envelope. In addition, multiple cage designs and materials allow for design flexibility and preset radial clearance simplifies the installation process.

<sup>1</sup> Based on  $1 \times 10^6$  revolutions  $L_{10}$  life, for the ISO life calculation method.

<sup>2</sup> Based on  $1 \times 10^6$  revolutions  $L_{10}$  life, for the ISO life calculation method.

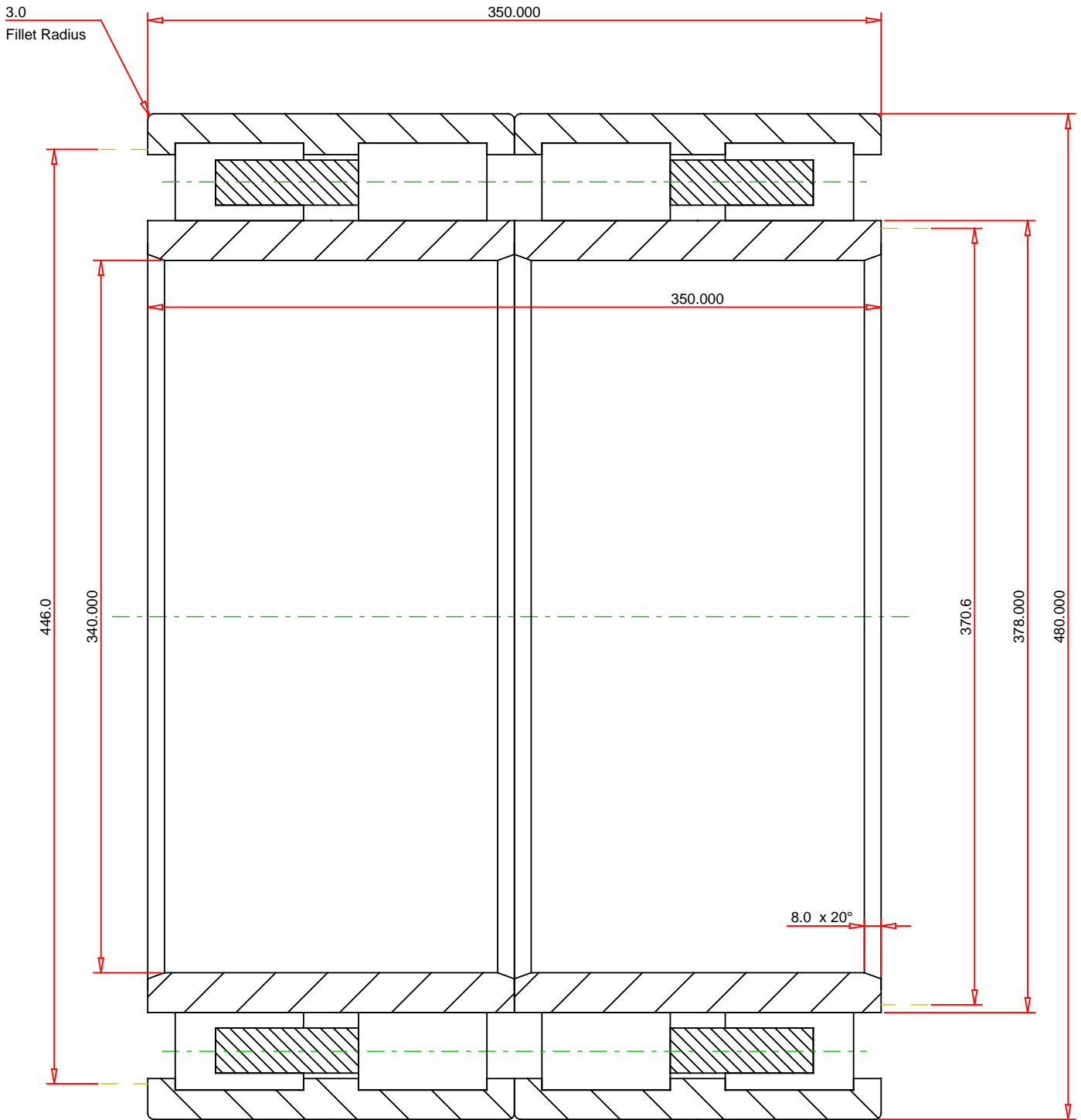

METRIC UNITS

Bearing Weight 199.3 kg

**TIMKEN**®

**340RYL1963**  
CYLINDRICAL ROLLER BEARING

**THE TIMKEN COMPANY**  
NORTH CANTON, OHIO USA

Dynamic Load Rating 5180000 N  
Static Load Rating 10880000 N

Every reasonable effort has been made to ensure the accuracy of the information contained in this writing, but no liability is accepted for errors, omissions or for any other reason.

**FOR DISCUSSION ONLY**