

**The Timken Company**

4500 Mt Pleasant St. NW

N. Canton, OH 44720

**Phone:** (234) 262-3000

**E-Mail:** [CustomerCAD@timken.com](mailto:CustomerCAD@timken.com) • **Web site:** [www.timken.com](http://www.timken.com)
**Part Number 23172EJW509C08, Spherical Roller Bearings - Steel Cage**

Spherical bearings are designed to manage high radial loads even when misalignment, poor lubrication, contamination, extreme speeds or critical application stresses are present.

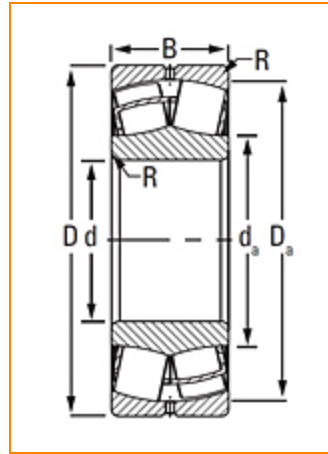

[Specifications](#) | [Factors](#) | [Dimensions](#) | [Abutment and Fillet Dimensions](#) | [Basic Load Ratings](#)

**Specifications**

<b>UPC Code</b>	087796164994
<b>Design Unit</b>	Metric
<b>d - Bore</b>	360.000 mm
<b>Lubrication Type</b>	Standard Grease
<b>Cage Type</b>	EJ
<b>Cage Material</b>	Steel
<b>Superseded Part</b>	23172CJW509C08

**Factors**

<b>e - ISO Factor<sup>1</sup></b>	0.29
-----------------------------------	------

<b>Y0 - ISO Factor<sup>2</sup></b>	2.24
<b>Y1 - ISO Factor<sup>3</sup></b>	2.29
<b>Y2 - ISO Factor<sup>4</sup></b>	3.42
<b>Reference Thermal Speed Rating (Grease)</b>	530 rpm
<b>Reference Thermal Speed Rating (Oil)<sup>5</sup></b>	590 rpm
<b>Cg - Geometry Factor<sup>6</sup></b>	0.1427

## Dimensions

<b>D - Outer Diameter</b>	600 mm 23.6220 in
<b>B' - Inner Ring Width</b>	192 mm 7.559 in
<b>B - Outer Ring Width</b>	192 mm 7.5590 in

## Abutment and Fillet Dimensions

<b>R - Inner Ring "To Clear" Radius<sup>7</sup></b>	4 mm 0.160 in
<b>r - Outer Ring "To Clear" Radius<sup>8</sup></b>	4 mm 0.16 in
<b>da - Inner Ring Backing Diameter</b>	416 mm 16.4000 in
<b>Da - Outer Ring Backing Diameter</b>	546.000 mm 21.500 in

## Basic Load Ratings

<b>C0 - Static Radial Rating</b>	7300000 N 1640000 lbf
<b>C1(2) - Dynamic Radial Rating (Two-Rows)</b>	4660000 N 1050000 lbf

<sup>1</sup> These factors apply for both inch and metric calculations. Consult your Timken representative for instruction on use.

<sup>2</sup> These factors apply for both inch and metric calculations. See engineering

<sup>3</sup> These factors apply for both inch and metric calculations. Consult your Timken representative for instruction on use.

<sup>4</sup> These factors apply for both inch and metric calculations. Consult your Timken representative for instruction on use.

<sup>5</sup> See thermal speed ratings in the engineering section.

<sup>6</sup> Geometry constant for Lubrication Life Adjustment Factor a3l.

<sup>7</sup> Maximum housing fillet radius that bearing corners will clear.

<sup>8</sup> These maximum fillet radii will be cleared by the bearing corners.

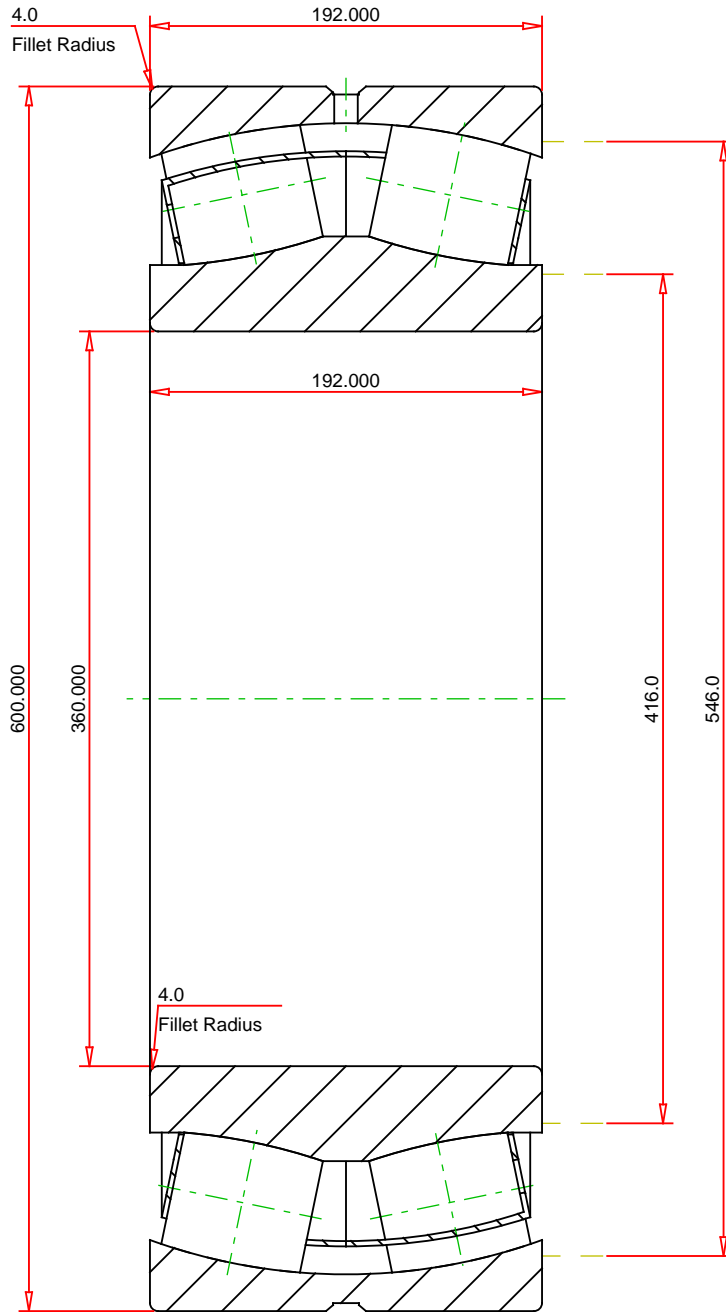

METRIC UNITS

Number of Rollers Per Row	22
ISO Factor e	0.29
ISO Factor Y0	2.24
ISO Factor Y1	2.29
ISO Factor Y2	3.42
Bearing Weight	kg
Cage Type	EJ
Cage Material	Steel

**TIMKEN**®

**23172EJW509C08**  
SRB ASSEMBLY

**THE TIMKEN COMPANY**  
NORTH CANTON, OHIO USA

Dynamic Radial Rating (Two Rows)	4660000	N
Static Radial Rating	7300000	N

Every reasonable effort has been made to ensure the accuracy of the information contained in this writing, but no liability is accepted for errors, omissions or for any other reason.

**FOR DISCUSSION ONLY**