



Allen-Bradley

ControlNet Scanner

1747-SCNR

Reference Manual

**Rockwell
Automation**

Important User Information

Solid state equipment has operational characteristics differing from those of electromechanical equipment. Safety Guidelines for the Application, Installation, and Maintenance of Solid State Controls (Publication SGI-1.1 available from your local Rockwell Automation sales office or online at <http://literature.rockwellautomation.com/>) describes some important differences between solid state equipment and hard-wired electromechanical devices. Because of this difference, and also because of the wide variety of uses for solid state equipment, all persons responsible for applying this equipment must satisfy themselves that each intended application of this equipment is acceptable.

In no event will Rockwell Automation, Inc. be responsible or liable for indirect or consequential damages resulting from the use or application of this equipment.

The examples and diagrams in this manual are included solely for illustrative purposes. Because of the many variables and requirements associated with any particular installation, Rockwell Automation, Inc. cannot assume responsibility or liability for actual use based on the examples and diagrams.

No patent liability is assumed by Rockwell Automation, Inc. with respect to use of information, circuits, equipment, or software described in this manual.

Reproduction of the contents of this manual, in whole or in part, without written permission of Rockwell Automation, Inc. is prohibited.

Throughout this manual, when necessary we use notes to make you aware of safety considerations.

WARNING

Identifies information about practices or circumstances that can cause an explosion in a hazardous environment, which may lead to personal injury or death, property damage, or economic loss.

IMPORTANT

Identifies information that is critical for successful application and understanding of the product.

ATTENTION

Identifies information about practices or circumstances that can lead to personal injury or death, property damage, or economic loss. Attentions help you identify a hazard, avoid a hazard, and recognize the consequence.

SHOCK HAZARD

Labels may be located on or inside the equipment (for example, drive or motor) to alert people that dangerous voltage may be present.

BURN HAZARD

Labels may be located on or inside the equipment (for example, drive or motor) to alert people that surfaces may be dangerous temperatures.

This publication contains new and revised information not in the last release.

New and Revised Information

See the table for a summary of the major additions in this manual.

| For | See Page |
|--|----------|
| An explanation of the processor and firmware levels that include the ControlNet explicit message instruction capability | 2-12 |
| New information about the ControlNet explicit message instruction that uses the CIP client management capability of module | 4-1 |

Other changes in this manual provide an update or clarification of the material.

Change Bars

Change bars (as shown with this paragraph) show the areas in this manual that are different from previous editions and indicate the addition of new or revised information.



Notes:

| | | |
|---|--|------|
| Preface | What This Manual Contains | P-1 |
| | Who Should Use This Manual | P-1 |
| | Common Techniques Used in This Manual. | P-1 |
| | Terminology | P-2 |
| | | |
| Install and Connect the ControlNet Scanner | Chapter 1 | |
| | What This Chapter Contains | 1-1 |
| | Identify Scanner Features | 1-1 |
| | Prepare for Module Installation | 1-2 |
| | Select the ControlNet Node Address. | 1-3 |
| | Insert the 1747-SCNR Scanner Into the Chassis | 1-3 |
| | Connect to a ControlNet Network | 1-5 |
| | Connect Programming Terminal to ControlNet Network | 1-6 |
| | SLC 500 I/O Configuration for the 1747-SCNR Module | 1-8 |
| | | |
| Prepare to Use the ControlNet Scanner | Chapter 2 | |
| | What This Chapter Contains | 2-1 |
| | What Your Scanner Does | 2-1 |
| | Communicate with Your SLC Processor | 2-1 |
| | Communicating with Your SLC processor Using M1 and M0 Files | 2-2 |
| | Understand ControlNet Data transfer | 2-3 |
| | Scheduled Data Transfer Operations on a ControlNet Network | 2-3 |
| | Unscheduled Data Transfer Operations on a ControlNet Network | 2-4 |
| | Link Layer Services | 2-4 |
| | Understand 1747-SCNR Mapping | 2-5 |
| | Discrete Input File | 2-5 |
| | 1747-SCNR M1 File. | 2-6 |
| | Discrete Output File. | 2-8 |
| | 1747-SCNR M0 File. | 2-9 |
| | Communicate with Your Devices. | 2-9 |
| | I/O Scheduled Data Transfer | 2-9 |
| | Unscheduled Data Server | 2-10 |
| | CIP Client Request Transfer | 2-10 |
| | | |
| Configure and Map Scheduled Data Exchange with RSNetWorx for ControlNet Software | Chapter 3 | |
| | What This Chapter Contains | 3-1 |
| | Begin the Configuration Process | 3-1 |
| | Questions to Ask. | 3-1 |
| | Data Transfer Mapping | 3-2 |

| | | |
|--|---|-----|
| Work with the ControlNet Explicit Message Instruction | Chapter 4 | |
| | What This Chapter Contains | 4-1 |
| | Understand the ControlNet Explicit Message Instruction . . . | 4-1 |
| | Work with the Explicit Message Instruction (CEM) | 4-2 |
| | CEM Instruction Parameters | 4-2 |
| | CEM Instruction Setup Screen Parameters | 4-3 |
| Troubleshoot | Chapter 5 | |
| | What This Chapter Contains | 5-1 |
| | Troubleshoot with the Status Indicators and Status Display | 5-1 |
| | Apply Chassis Power | 5-2 |
| | Alphanumeric Display | 5-2 |
| | OK Indicator and Display Mnemonics | 5-3 |
| Local Database Access Using PLC-5 MSG Instructions | Appendix A | |
| | What This Appendix Contains | A-1 |
| | What We Assume | A-1 |
| | Read and Write Access To 1747-SCNR Local Database Using PLC-5 MSG Instruction | A-1 |
| Use CIP Messaging to Access Local Database and ControlNet Data Files Access | Appendix B | |
| | What This Appendix Contains | B-1 |
| | What We Assume | B-1 |
| | Read and Write Access to 1747-SCNR Data Files Using Assembly Object Services | B-1 |
| | Assembly Object Instance Numbers Supported for Get and Set Member on Data Attribute | B-2 |
| | 1747-SCNR Memory Layout | B-3 |

CIP Client Management**Appendix C**

| | |
|---|------|
| What This Appendix Contains | C-1 |
| What We Assume | C-1 |
| CIP Client Area | C-2 |
| Send a Get Attribute All Request to Node 14 Identity Object | C-4 |
| SLC 500 Processor: N7 Data File (hex) | C-5 |
| SLC 500 Ladder Program | C-6 |
| SLC 500 Processor: Data Files (hex) | C-7 |
| Send a Set Attribute Single Request | C-8 |
| SLC 500 Processor: N7 Data File (hex) | C-9 |
| Example: SLC 500 Ladder Program | C-10 |
| SLC 500 Processor: Target Input Data File (hex) . | C-11 |
| Send a Set Member Request. | C-12 |
| SLC 500 Processor: N7 Data File (hex) | C-13 |
| Example: SLC 500 Ladder Program | C-14 |
| SLC 500 Processor: Target Input Data File (hex) . | C-15 |

Example of Reset Bit Management Appendix D

| | |
|---------------------------------------|-----|
| What This Appendix Contains | D-1 |
| What We Assume | D-1 |
| Example | D-1 |

Application Examples**Appendix E**

| | |
|---|------|
| What This Appendix Contains | E-1 |
| What We Assume | E-1 |
| Example 1: Configure the 1747-SCNR Scanner with the 1746-IV16 Input Module | E-1 |
| Hardware Setup. | E-1 |
| Configure the ControlNet Network with RSNetWorx for ControlNet | E-1 |
| Example 2: Configure the 1747-SCNR Scanner with the 1746-NIO4V Analog Input/Output Module. | E-9 |
| Hardware Setup. | E-9 |
| Configure the ControlNet Network with RSNetWorx for ControlNet Software. | E-9 |
| Configure a Module Connection. | E-16 |
| Example 3: Configure the 1747-SCNR Scanner with the 1746-NI8 Analog Input Module | E-19 |
| Hardware Setup. | E-19 |
| Configure the ControlNet Network with RSNetWorx for ControlNet Software | E-19 |
| Configure a Module Connection. | E-25 |
| Example 4: Configure the 1747-SCNR Scanner with the 1746-BAS Series B Interface Module | E-28 |
| Hardware Setup. | E-28 |
| Configure the ControlNet Network with RSNetWorx for ControlNet Software | E-28 |
| Configure a Module Connection. | E-34 |
| Example 5: Configure the 1747-SCNR Scanner with the 1794-IE4XOE2 Analog Combo Module. | E-41 |
| Hardware Setup. | E-42 |
| Configure the ControlNet Network with RSNetWorx for ControlNet Software | E-42 |
| Configure a Module Connection. | E-48 |
| Example 6: Creating Peer-to-Peer Scheduled Connections Between 1747-SCNR ControlNet Scanners | E-51 |
| Hardware Setup. | E-51 |
| Configure the ControlNet Network with RSNetWorx for ControlNet Software | E-52 |
| Configure a Scheduled Connection Between ControlNet Scanners. | E-54 |

What This Manual Contains Use this manual to install, configure, and apply the features of the scanner. See the table for a list of where to find specific information. For specification and hazardous locations information, refer to SLC ControlNet Scanner Installation Instructions, publication 1747-IN059.

| For Information About | See |
|--|------------|
| How to install and connect the module | Chapter 1 |
| How to prepare to install the module | Chapter 2 |
| How to configure and map scheduled data exchange using RSNetWorx for ControlNet software | Chapter 3 |
| How to use the SLC ControlNet explicit message instruction | Chapter 4 |
| How to troubleshoot and read LEDs | Chapter 5 |
| Local database access using PLC-5 MSG instructions | Appendix A |
| Local database and ControlNet data files access using CIP messaging | Appendix B |
| CIP client management | Appendix C |
| Reset bit management | Appendix D |
| Application examples | Appendix E |

Who Should Use This Manual

We wrote this manual for control engineers and technicians who are installing, programming, and maintaining a control system that includes an SLC 500 processor communicating on a ControlNet network with a ControlNet scanner. Here is what we assume.

- You are developing a ControlNet network using an SLC processor in conjunction with a ControlNet scanner.
- You know each of your device's I/O parameters and requirements.
- You understand SLC processor programming and operation.
- You are familiar with RSNetWorx for ControlNet software.
- You are familiar with the Microsoft Windows environment.

Common Techniques Used in This Manual

We use the following conventions throughout this manual.

- Numbered lists provide sequential steps.
- Bulleted lists provide information, not procedural steps.

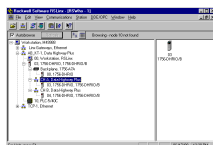

The screen captures shown in this manual are pictures of the software’s actual screens.

Terminology

See these tables for a list of ControlNet network terms and acronyms used in this manual.

| Term | Definition |
|------------------------------|---|
| Actual Packet Interval (API) | The measure of how frequently a specific connection produces its data. |
| Big-endian | A computer architecture in which, within a given multi-byte numeric representation, the most significant byte has the lowest address (the word is stored big-end-first - typically Motorola architecture). |
| Bit | A unit of information consisting of a 1 or a 0. This is the smallest data unit that can be transmitted. |
| Class | A set of objects all of which represent a similar system component. A class is a generalization of the object, a template for defining variables and methods. All objects in a class are identical in form and behavior, but they may contain different attribute values. |
| Client | <ol style="list-style-type: none"> 1. An object that uses the services of another (server) object to perform a task. 2. An initiator of a message to which a server reacts. |
| Connection | A logical binding between two application objects. These application objects may be in the same or different devices. |
| Connection Path | The attribute is made up of a byte stream that defines the application object to which a connection instance applies. |
| Consume | The act of receiving data from a producer. |
| Consumer | A node that is receiving data from a producer. |
| Device | A physical hardware connection to the link. A device may contain more than one node. |
| Error | A discrepancy between a computed, observed, or measured value or condition and the specified or theoretically correct value or condition. |
| Frame | Single data transfer on a link. |
| Instance | The actual physical presentation of an object within a class. Identifies one of many objects within the same object class. |
| Link | A collection of nodes with unique MAC IDs. Segments connected by repeaters make up a link; links connected by routers make up a network. |
| Little-endian | A computer architecture in which, within a given multi-byte numeric representation, the least significant byte has the lowest address (the word is stored little-end first - typically Intel architecture). |

| | |
|----------------------------------|--|
| Multicast Connection | A connection where one node produces data and multiple nodes consume that exact same data. Connections can be either point-to-point or multicast. |
| Network | A series of nodes connected by some type of communication medium. The connection paths between any pair of nodes can include repeaters, routers, and gateways. |
| Network Access Port (NAP) | Physical Layer variant that lets a temporary node to be connected to the link by connection to the NAP of a permanent node. |
| Network Address or Node Address | A node's address on the link (also called MAC ID). |
| Network Status Indicators | Indicators on a node displaying the status of the Physical and Data Link Layers. |
| Network Update Interval (NUI) | A single occurrence of the ControlNet Network Update Time (NUT). |
| Network Update Time (NUT) | Repetitive time interval in which data can be sent on the link. |
| Node | A connection to a link that requires a single MAC ID. |
| Object | <ol style="list-style-type: none"> 1. An abstract representation of a computer's capabilities. Objects can be composed of any or all of the following components: data (information which changes with time) configuration (parameters for behavior) methods (things that can be done using data and configuration) 2. A collection of related data (in the form of variables) and methods (procedures) for operating on that data that have clearly defined interface and behavior. |
| Originator | The client responsible for establishing a connection path to the target. |
| Point to Point Connection | A connection that exists between two nodes only. Connections can be either point-to-point or multicast. |
| Produce | Act of sending data to a consumer. |
| Producer | A node that is responsible for transmitting data. |
| Redundant Media | A system using more than one medium to help prevent communication failures. |
| Requested Packet Interval (RPI) | The measure of how frequently the originating application requires the transmission of data from the target application. |
| Scanner Configuration Tool (SCT) | Software tool that lets you to configure scheduled connections, map data for these connections, and monitor the status for the configured connections. |
| Scheduled | Data transfers that occur in a deterministic and repeatable manner on predefined NUTs. |
| Server | An object which provides services to another (client) object. |
| Service | Operation or function that an object performs upon request from another object. |
| Target | The end-node to which a connection is established. |
| Unscheduled | Data transfers that use the remaining time in the NUT after the scheduled transfers have been completed. |

| Abbreviations and Acronym | Meaning |
|----------------------------------|--|
| API | Actual packet interval |
| BNC | A connector for coaxial cable having a bayonet-type shell with two small knobs on the female connector which lock into spiral slots in the male connector when it is twisted |
| CIP | The control and information protocol defined by part 4 of the ControlNet standard. CIP includes both connected and unconnected messaging. |
| LED | Light emitting diode |
| MAC ID | The address of a node |
| NAP | Network access port |
| NUI | Network update interval |
| NUT | Network update time |
| RPI | Requested packet interval |
| SCT | Scanner configuration tool |

Install and Connect the ControlNet Scanner

What This Chapter Contains

This chapter describes how to install and connect your ControlNet 1747-SCNR scanner. See the table that shows where to find specific information in this chapter.

| For Information About | See Page |
|--|----------|
| Identifying scanner features | 1-1 |
| Preparing the module for installation | 1-2 |
| Selecting the ControlNet node address | 1-3 |
| Inserting the 1747-SCNR into an SLC chassis | 1-4 |
| Connecting the 1747-SCNR to a ControlNet network | 1-5 |
| SLC 500 I/O configuration | 1-8 |

Identify Scanner Module Features

The following drawing identifies the features of the 1747-SCNR scanner.

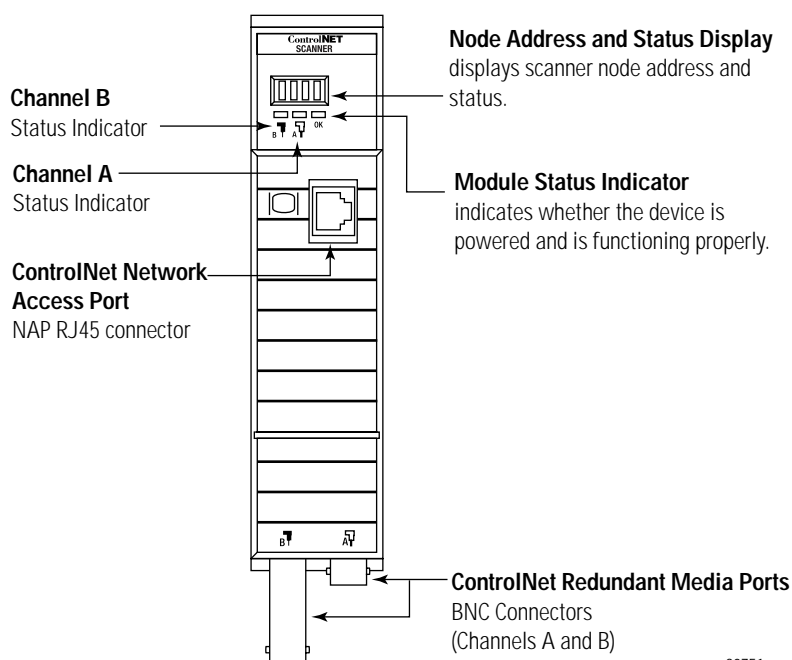

30751

Prepare for Module Installation

Before you install your module, you need the following items:

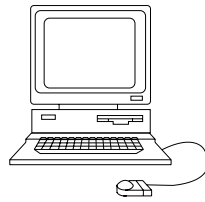

Personal Computer with Microsoft Windows

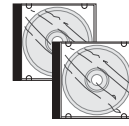

RSNetWorx for ControlNet software, Catalog Number 9357-CNETL3

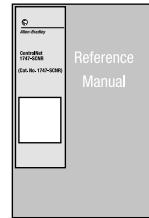

1747-SCNR Scanner Reference Manual, Publication 1747-RM623 (this manual)

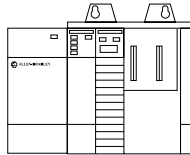

SLC 1746 Chassis with SLC 5/02, 5/03, 5/04, or 5/05 Processor and Appropriate Programming Software (RSLogix 500 Software)



ControlNet 1784-PCC (shown), or 1784-PCIC, or 1784-KTCX15, or 1770-KFC15 Module

41523

Before you install the module, you must know how to do this.

- Program and operate an Allen-Bradley SLC 500 programmable controller.
- Install and configure the devices on your ControlNet network.

The 1747-SCNR scanner fits in any slot of the chassis except for the leftmost slot of the first chassis, which is reserved for the SLC 500 processor.

Select the ControlNet Node Address

Select the ControlNet node address of the 1747-SCNR module by setting the two 10-digit rotary switches on the top of the scanner.

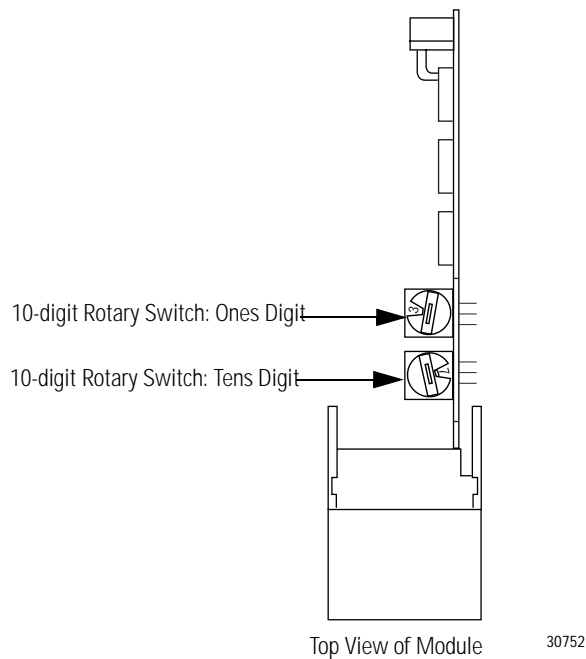

You can select a node address from 01 to 99 for a device on a ControlNet link. Zero (00) is not a valid node address.

IMPORTANT

Since 00 is the default value from manufacturing, you must change the node address when using the scanner for the first time. Turning on the scanner with the node address set to 00 clears the module memory back to the factory default.

Insert the 1747-SCNR Scanner Into the Chassis

To insert the 1747-SCNR scanner into the SLC chassis complete these procedures.

ATTENTION



Do not install the 1747-SCNR scanner with the chassis power supply on. Installing the module with the chassis power supply on may damage the module.

1. Turn off the SLC chassis power supply.

IMPORTANT

If you disconnect the ac power, you lose the chassis ground. Electrostatic damage (ESD) protection is lost.

2. Select a slot for the module in the chassis, choosing any slot except the left-most slot of the first chassis, which is reserved for the SLC 500 processor.

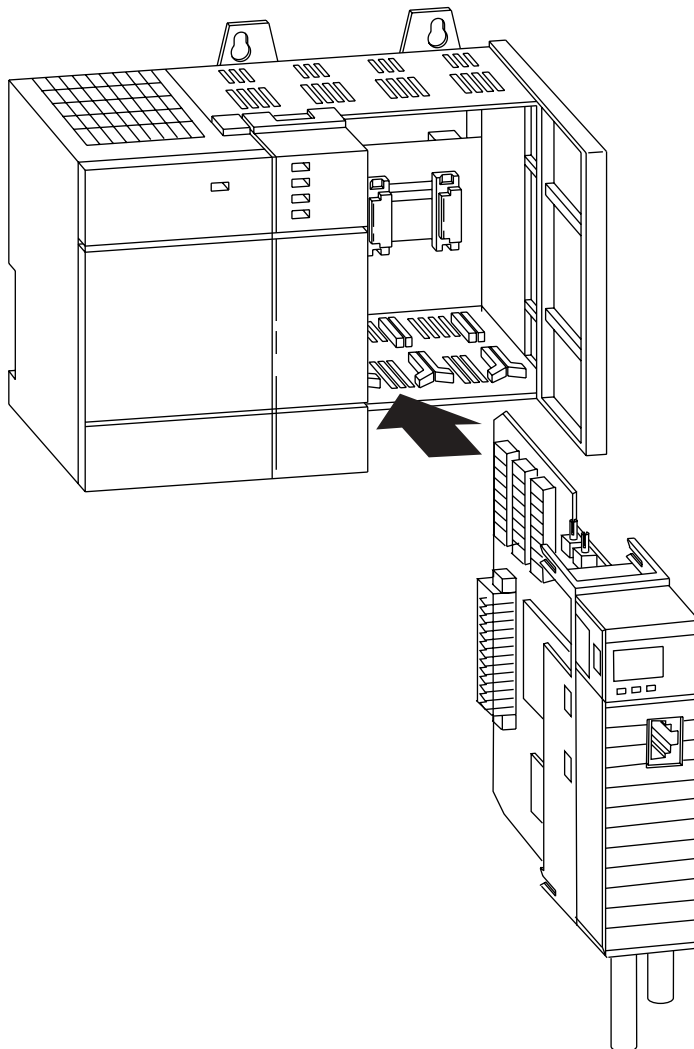

30801-M

3. Insert the module into the slot you have selected, noting that we recommend that you insert the 1747-SCNR scanner as close to the chassis power supply as possible.
4. Apply firm and even pressure to seat the module in the I/O chassis backplane connectors.
5. Restore power to the SLC chassis.

Connect to a ControlNet Network

Connect the 1747-SCNR scanner to a ControlNet network via a tap with a 1 m (39.4 in.) drop cable. Four taps are available from Rockwell Automation, Inc., as shown in the figure.

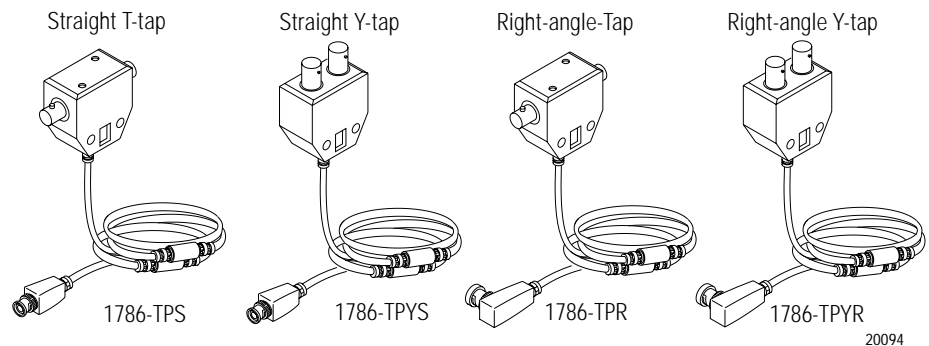

IMPORTANT

Allen-Bradley ControlNet taps contain passive electronics and must be purchased from Rockwell Automation for the network to function properly.

After terminating your segments, connect your node to the network.

WARNING



If you connect or disconnect the ControlNet cable with power applied to this module or any device on the network, an electrical arc can occur. This could cause an explosion in hazardous location installations. Be sure that power is removed or the area is nonhazardous before proceeding.

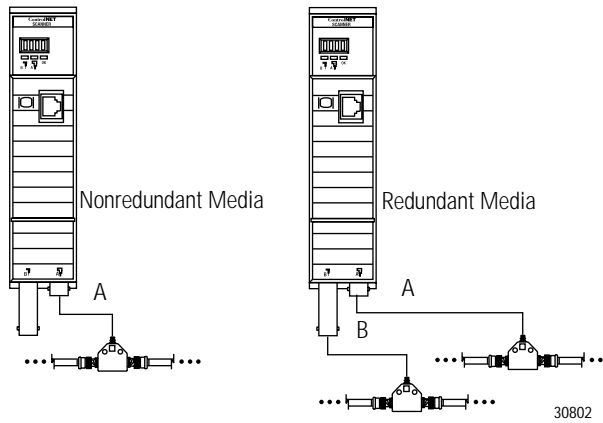

Remove the tap's dust cap—located on the straight or right-angle connector—and set it aside.

If Your Network Supports Connect the Tap's Straight or Right-angle Connector

| | |
|--------------------|---|
| Nonredundant media | To the channel A connector on the scanner—channel B is not used. ⁽¹⁾ |
| Redundant media | From the trunk-cable A to channel A on the scanner and from trunk-cable B to channel B on the scanner |

⁽¹⁾ We recommend using channel A for nonredundant media.

For detailed information on planning and installing your ControlNet system, see the table for a list of related publications.

| Publication | Publication Number |
|---|--------------------|
| ControlNet Coax Tap Installation Instructions | 1786-IN007 |
| ControlNet Network Access Cable Installation Instructions | 1786-TD006 |
| Industrial Automation Wiring and Grounding Guidelines | 1770-IN041 |

Connect Programming Terminal to a ControlNet Network

You can connect the programming terminal to a ControlNet network through a:

- ControlNet product NAP using a network access cable (1786-CP).
- tap on a ControlNet network.

ATTENTION



Do not connect the same communication card to both the NAP and a tap on the ControlNet network.

Using 1784-PCIC communication card on coax media ①

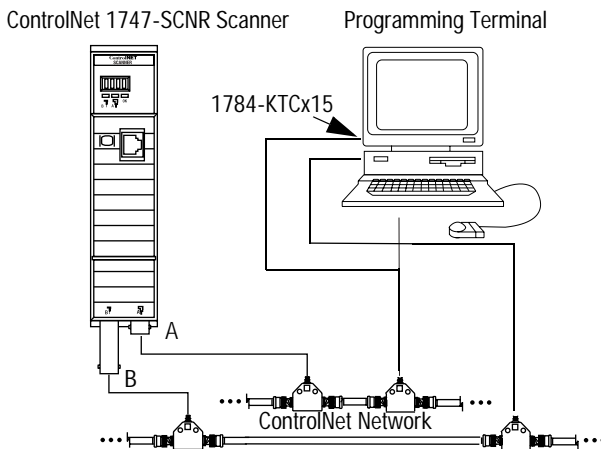

Using 1784-PCC or -PCIC communication card and NAP ①

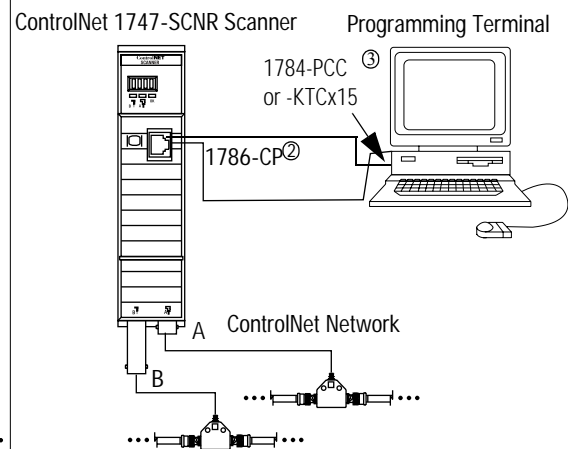

Using 1770-KFC15 communication interface on coax media ①

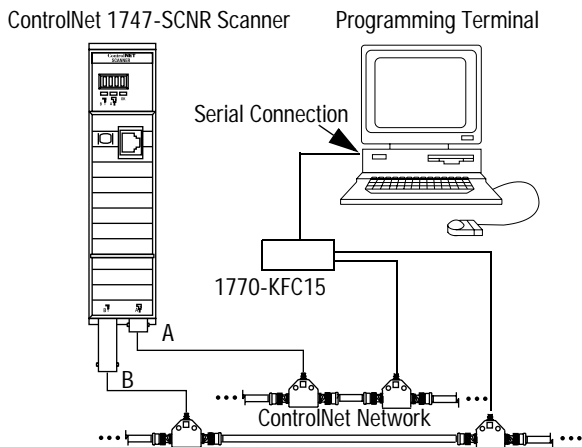

Using 1770-KFC15 communication interface and NAP ①

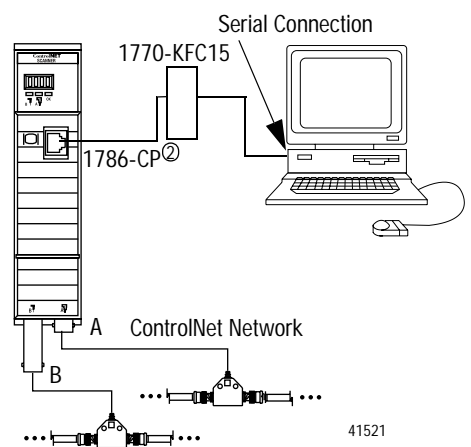

① Shown with redundant media (redundant media is not required).

② The network access cable (1786-CP) can be plugged into any ControlNet product's NAP to provide programming capability on the ControlNet network. A programming terminal connected through this cable is counted as a node and must have a unique address.

③ The 1784-PCC ships with its own ControlNet cable (1784-PCC1).

ATTENTION



Use the 1786-CP cable when connecting a scanner to the network through a NAP. Using a commercially-available RJ-style cable could result in network failure.

SLC 500 I/O Configuration for the 1747-SCNR Module

Select the I/O card. If you do not have an I/O card, complete the following procedure.

Open RSLogix 500 software and use the following procedure to configure the 1747-SCNR module.

In the RSLogix 500 project Window:

1. Open the I/O Configuration window.
2. Select the 1747-SCNR slot number.
3. Select the 1747-SCNR module from the current available cards list. If it is not available, perform the following steps:
 - a. Choose the other ..Requires I/O card type ID line in the Current cards available list.
 - b. In the Other type I/O Card window, type 13628.
 - c. On the line associated with the scanner slot, the I/O Configuration window will report the following:

OTHER I/O Module- ID Code = 13628
 - d. Double-click the scanner line to open the Advanced I/O Configuration window.
 - e. Set M0 Length to 1651 (decimal) and M1 Length to 608 (decimal).
4. Close the I/O Configuration and Advanced I/O Configuration windows.

Prepare to Use the ControlNet Scanner

What This Chapter Contains Read this chapter to understand how to use your ControlNet 1747-SCNR Scanner. The following table describes what this chapter contains and where to find specific information.

| For Information About | See Page |
|--|----------|
| What your scanner does | 2-1 |
| Communicating with your SLC processor | 2-1 |
| Understanding ControlNet data transfer | 2-3 |
| Understanding 1747-SCNR mapping | 2-5 |
| Communicating with your devices | 2-9 |

What Your Scanner Does

In a typical configuration, the scanner acts as an interface between ControlNet devices and an SLC processor. The scanner communicates with ControlNet devices over the network to do this:

- Read inputs from a device.
- Write outputs to a device.
- Issue native ControlNet requests to a remote node on the ControlNet link (CIP client).
- Download configuration data.

Communicating with Your SLC Processor

The scanner communicates with the processor in the form of M1/M0 File Transfers and/or Discrete I/O (DIO). Information exchanged includes the following.

- Device I/O data
- Status and control information
- CIP client requests and responses
- Local database

An M1/M0 file transfer is a method of moving large amounts of data between an SLC 500 processor and its scanner.

Discrete input and output (DIO) is the transfer of one to 32 words between an SLC 500 processor and a scanner. All 32 words of input data and all 32 words of output data are updated on each SLC program scan.

Communicating with Your SLC processor Using M1 and M0 Files

Your processor can communicate with the scanner via M1 file transfer reads and M0 file transfer writes.

The scanner does not send data to your processor. Data transfer between your scanner and the processor must be initiated by the processor. For example, data is sent, or written, to the scanner by your processor by placing the data in the M0 file. This data is organized in the scanner and then, based on the area you updated, the appropriate action is initiated to send it on the ControlNet network.

An M1 file transfer is the transfer of data from the scanner to the processor. The scanner makes data collected from the network's devices available for the processor to read.

An M0 file transfer is the transfer of data from the SLC 500 processor to the scanner. The processor writes data to the scanner's memory.

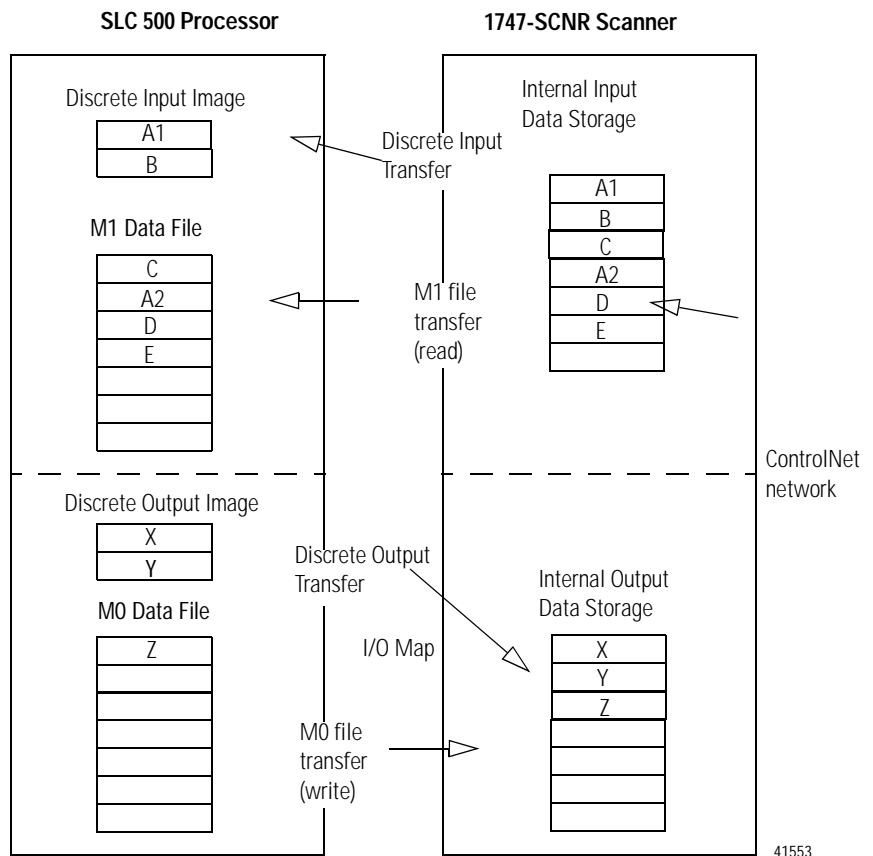

Understand ControlNet Data transfer

The ControlNet system is designed to do this:

- Provide high-speed, repeatable, deterministic I/O transmission.
- Let control and message information co-exist on the same physical media.
- Make sure that I/O data transfers are not affected by:
 - programming-terminal activity.
 - inter-scanner message activity on the network.

Scheduled Data Transfer Operations on a ControlNet Network

ControlNet scheduled data transfer on a 1747-SCNR Scanner:

- is continuous.
- transmits on the network asynchronously to the ladder logic program scan.
- occurs at the actual rate that is determined by RSNetWorx for ControlNet software.

For discrete I/O data transfer between logic scans (during housekeeping), the following updates occur.

- The gathered input image is moved from the scanner to the SLC processor's input image file for use during the next logic scan.
- The 1747-SCNR output data is updated with data from the SLC processor output image file and is sent during the next scheduled communication.

M0 and M1 files are data files that reside in the 1747-SCNR scanner only. Data from these files will be available to the SLC processor using ladder instructions. Scheduled data update will be triggered by the Housekeeping period start, which occurs once per scan. This process is illustrated below.

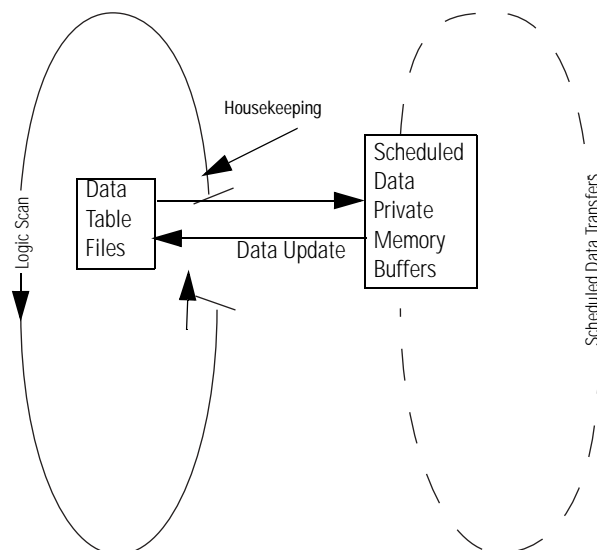

SLC 500 Program Scan Data Tables Files Housekeeping 1747-SCNR Scheduled Data

41554

Unscheduled Data Transfer Operations on a ControlNet Network

The ControlNet network lets you use unscheduled messaging in addition to deterministic delivery.

Unscheduled operations include:

- peer-to-peer messaging.
- messaging from any remote CIP client device.
- messaging from programming devices.
- CIP client message initiated by the SLC processor ladder program.

This process is illustrated in the figure.

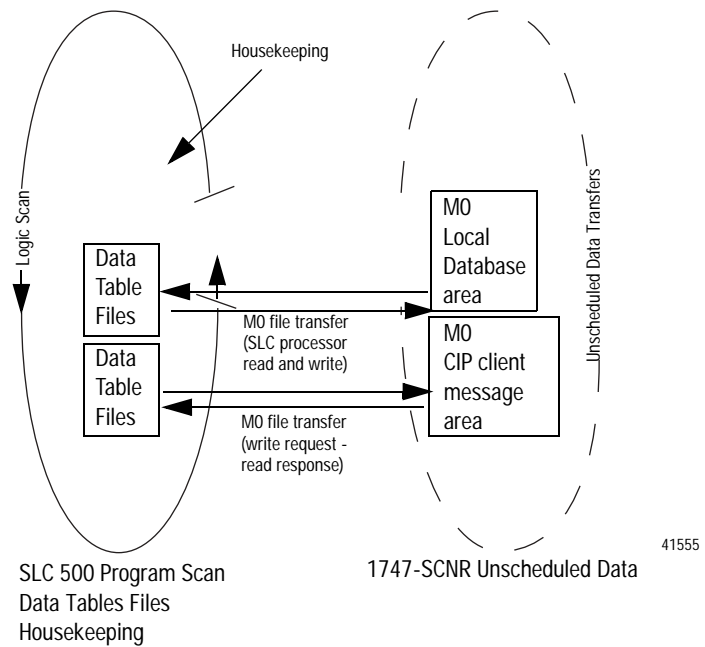

Link Layer Services

The figure illustrates link layer services.

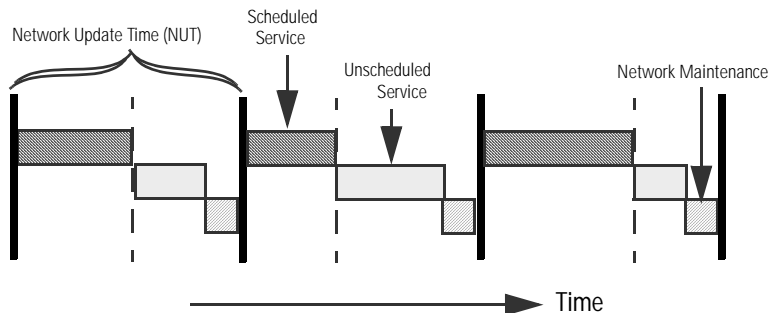

41556

The ControlNet system places your scheduled transfers in the first part of each network update interval (NUI). Time is automatically reserved for network maintenance, and unscheduled transfers are performed during the remainder of the interval.

Unscheduled messaging on a ControlNet network is non-deterministic. Your application and your configuration (for example, number of nodes, application program, NUT) determine how much time there is for unscheduled messaging.

IMPORTANT

The ControlNet network reserves time for at least one unscheduled transfer per NUI.

Understand 1747-SCNR Mapping

The 1747-SCNR scanner and the SLC processor exchange the following information through the backplane:

- Input data
- Output data
- Status data
- Command data
- CIP messages

The 1747-SCNR mapping is described in the following. Bit field descriptions follow each table.

Discrete Input File

| Word Offsets | Word Size | ControlNet Transfer Mode | Contents | Description |
|--------------|-----------|--------------------------|---|---|
| 0 | 1 | N/A | Module Status (see the next section, "Module Status") | Bit field reporting general status information. |
| 1-31 | 31 | Scheduled | ControlNet Input Data | You can map up to 31 words of input data using RSNetWorx for ControlNet software. |

Module Status (I:e.0)

| | |
|-----------|--|
| Bit 0 | 1747-SCNR Module Faulted. |
| Bit 1 | 1747-SCNR Communication Module Fault The 1747-SCNR scanner is not on line. See M1 word 2 (M1:e2) for the ControlNet network status. |
| Bit 2 | 1747-SCNR Connection Fault There is a fault in at least one scheduled connection. |
| Bit 3-7 | Reserved. |
| Bit 8 | Reset 1747-SCNR Module Acknowledge The 1747-SCNR scanner will complement this bit each time the scanner is reset due to complementing the Reset module command bit (O:e.0/8 where e is the scanner slot number). See Example of Reset Bit Management. |
| Bit 9 | Disable ControlNet Scheduled Connections Acknowledge The 1747-SCNR scanner will set this bit when the Disable ControlNet Scheduled Connections Command bit is set (O:e.0/9) and all scheduled connections have been closed. The 1747-SCNR scanner will clear this bit when the Disable ControlNet Scheduled Connections Command bit is cleared. |
| Bit 10 | Scanner Mode The 1747-SCNR scanner clears this bit when it is in idle mode. The 1747-SCNR Scanner sets this bit when it is in run mode. |
| Bit 11-15 | Reserved. |

1747-SCNR M1 File

| Word Offsets | Word Size | ControlNet Transfer Mode | Contents | Description |
|--------------|-----------|--------------------------|---|---|
| 0 | 1 | N/A | Reserved | Reserved for future use. |
| 1 | 1 | N/A | Module Status (See the next page "Module Status") | Value indicating the current operational status of the module. See the Troubleshooting for probable causes and recommended actions. |
| 2 | 1 | N/A | ControlNet Status (See the next page "ControlNet Status") | Value indicating the current channel LEDs. |
| 3-255 | 253 | Scheduled | ControlNet Input Data | You can map scheduled input data in this area using RSNetWorx for ControlNet software. |
| 256-599 | 344 | N/A | Reserved | Reserved. |
| 600-607 | 8 | N/A | Connection Status | Bit field reporting scheduled connections status. Two consecutive bits per scheduled connection: Connection State (Even bit numbers) 1:connection opened 0:connection closed Remote Device Mode (Odd bit numbers) 1:remote device is in run mode 0:remote device is in idle mode |

Module Status (M1:e.1)

See Troubleshooting for probable causes and recommended actions.

| Value | Description |
|-------|---|
| 0x20 | The scanner is not configured. |
| 0x21 | The current configuration is not valid. |
| 0x22 | Connections are configured, but no connections are established. |
| 0x23 | Connections are configured, but only 25% are successfully established. |
| 0x24 | Connections are configured, but only 50% are successfully established. |
| 0x25 | Connections are configured, but only 75% are successfully established. |
| 0x26 | All configured connections are established. |
| 0x42 | The node address is set to 00. This caused the scanner to erase network and connection configuration stored in flash. |
| 0x43 | The scanner detected a network error due to a ControlNet cable problem or there are no other nodes on the network. |
| 0x44 | The scanner has the same ControlNet address as another device on the network. |

ControlNet Status (M1:e.2)

See the table that contains bit numbers and their descriptions.

| | | |
|----------|------------------|-----------------------|
| Bit 0-2 | Channel A status | |
| | Value | LED State |
| | 000 | Off |
| | 001 | Green |
| | 010 | Flashing green/off |
| | 011 | Flashing red/off |
| | 100 | Flashing red/green |
| | 101 | Alternating red/off |
| | 110 | Alternating red/green |
| | 111 | Red |
| Bit 3 | Reserved | |
| Bit 4-6 | Channel B status | |
| | Value | LED State |
| | 000 | Off |
| | 001 | Green |
| | 010 | Flashing green/off |
| | 011 | Flashing red/off |
| | 100 | Flashing red/green |
| | 101 | Alternating red/off |
| | 110 | Alternating red/green |
| 111 | Red | |
| Bit 7-15 | Reserved | |

Discrete Output File

| Word Offsets | Word Size | ControlNet Transfer Mode | Contents | Description |
|--------------|-----------|--------------------------|------------------------|--|
| 0 | 1 | N/A | Module Command | Bit field used to send commands to the 1747-SCNR Scanner. |
| 1-31 | 31 | Scheduled | ControlNet Output Data | You can map up to 31 words of output data using RSNetWorx for ControlNet software. |

Module Command (0:e.0)

| | |
|-----------|--|
| Bit 0-7 | Reserved |
| Bit 8 | <p>Reset Scanner Command</p> <p>By complementing this bit, you reset the 1747-SCNR scanner (the reset occurs when the SLC slot is de-activated).</p> <p>It is important to note that if you do not disable the slot while the scanner is resetting, the SLC module will fault with the error code nn57h (specifically, I/O module in slot nn did not respond to a lock shared memory command in the requested time limit) where nn is the slot number of the scanner. This is why the reset bit change is not taken into account until the slot is disabled.</p> |
| Bit 9 | <p>Disable ControlNet Scheduled Connections Command</p> <p>When the bit value is 1, the 1747-SCNR scanner will close all scheduled connections.</p> <p>When the bit value is 0, the 1747-SCNR scanner will enable all scheduled connections.</p> |
| Bit 10 | <p>Scanner Mode Command</p> <p>When the bit value is 0, the 1747-SCNR scanner is forced to Idle mode.</p> <p>When the bit value is 1, the scanner's mode will be determined by the mode of the processor in slot 0.</p> |
| Bit 11-15 | Reserved |

1747-SCNR M0 File

| Word Offsets | Word Size | ControlNet Transfer Mode | Contents | Description |
|--------------|-----------|--------------------------|-------------------------|---|
| 0-2 | 3 | N/A | Reserved | Reserved. |
| 3-255 | 253 | Scheduled | ControlNet Output Data | Using the RSNetWorx for ControlNet software, you can map scheduled output data in this area. |
| 256-699 | 444 | N/A | Reserved | Reserved. |
| 700-955 | 256 | Unscheduled | Local Database | Memory area used by remote devices to read or write data using CIP messaging or PLC-5 messaging. |
| 1000-1650 | 651 | Unscheduled | CIP Client Message Area | Memory used to send CIP client requests. These messages are then sent by the 1747-SCNR module as unscheduled messaging. |

Only Input and Output data (from Input file, Output file, M0 ControlNet Output data area, and M1 ControlNet Input data area) are exchanged during scheduled time.

Data transfer to the M0 Local Database is performed using Unscheduled messaging. Services available to read or write in this area are Set Attribute Single, Get Attribute Single, Set Member, and Get Member.

Communicating with Your Devices

The 1747-SCNR scanner supports up to 64 simultaneous scheduled connections and up to 50 simultaneous unscheduled connections. The 1747-SCNR scanner also supports up to 32 simultaneous incoming unconnected requests.

I/O Scheduled Data Transfer

Data received from the devices, or input data, is organized by the scanner and made available to your processor in the Input file or the M1 ControlNet data area.

Data received from your SLC processor, or output data, is stored within the Output file or M0 ControlNet data area. The 1747-SCNR scanner can then send the data to your remote ControlNet devices.

All scheduled data transfer to Input, Output, M0 and M1 files must be mapped on a ControlNet network. You have to specify where I/O data is to be read from or written to, in other words, mapped. Data size and location within 1747-SCNR data files have to be configured for each connection you want to setup with a remote device. The configuration is performed using RSNetWorx for ControlNet software.

Unscheduled Data Server

The scanner supports some CIP data server functionality on a specific local database of 256 words located in the M0 file. Any device on ControlNet can read or write in this database using the supported services as described in Local Database Access Using PLC-5 MSG Instructions and Local Database and ControlNet Data Files Access Using CIP Messaging.

The SLC processor that has read and write access to this area is then able to receive or modify data into the database.

Using this Local Database:

- a device can send data to an SLC processor using unscheduled data transfer.
- two devices can exchange unscheduled data by using this database as a proxy data storage.
- a PLC-5 controller can exchange data with the SLC processor by reading or writing in this area using MSG instructions.
- an HMI can exchange data with the SLC processor by reading or writing in this area using PLC-5 type read and write commands.

CIP Client Request Transfer

The scanner provides some limited CIP client messaging capability. Using ladder programming, you can manually build a message request for up to approximately 240 words of in and approximately 240 words of out data, to let configuration and other limited messaging to remote devices.

The CIP client message management is detailed in CIP Client Management.

SLC 5/03, 5/04, and 5/05 processors at OS firmware level, series C, FRN 10, or later, include ControlNet explicit message (CEM) instruction capability. The CEM instruction uses the CIP client message capability of the scanner. See Work with the ControlNet Explicit Message Instruction section for details.

Notes:

Configure and Map Scheduled Data Exchange with RSNNetWorx for ControlNet Software

What This Chapter Contains This chapter provides information about the mapping of scheduled connections between 1747-SCNR remote devices. This chapter also contains questions you should ask before configuring your 1747-SCNR scanner. The following table describes what this chapter contains and its location.

| For Information About | See Page |
|-------------------------------------|----------|
| Beginning the configuration process | 3-1 |
| Questions to ask | 3-1 |
| Data transfer mapping | 3-2 |

Begin the Configuration Process

Planning before configuring your scanner helps make sure you can:

- use your memory bandwidth efficiently.
- give attention to device-specific needs and requirements.
- give priority to critical I/O transfers.
- leave room for expansion.

Questions to Ask

Here are some questions you should ask yourself before you begin configuring the 1747-SCNR scanner:

- What is on your network?

This is a very important question to answer. You should be familiar with each device's:

- communication requirements.
 - I/O importance and size.
 - frequency of message delivery.
- How might this network appear in the future?

At this point in your planning, it is advantageous for you to have some idea of how the network could be expanded. When mapping your I/O, you have the opportunity to leave room for future I/O. Answering this question now can save time and effort in the future.

Data Transfer Mapping

You can use the configuration software (RSNetWorx for ControlNet software) to select either Input or M1 files for input data and either Output or M0 files for output data. However, it is more appropriate to use Input and Output files for critical I/O data transfer and M1 and M0 for non-critical I/O data transfer.

Input and Output files contain 31 words each. These files are appropriate for discrete data. If you have more than 31 words to transfer, you have to map the remaining connections in M1 and M0 ControlNet data areas.

For input data, you can map your connections anywhere in Input and M1 ControlNet data areas. It is not possible to overlap the mapping of two independent input connections.

For output data, you can map your connections anywhere in Output and M1 ControlNet data areas (refer to chapter 2 for exact memory mapping.) The overlapping of two output connections is authorized.

IMPORTANT

It is your responsibility to check that no unexpected overlapping has been configured.

Data exchanged through a single connection cannot be split between two distinct locations. This means that a 5 word connection cannot start at location I:29 and continue at another location in the M1 file. Likewise, you cannot configure this connection with two first words at address M1:e.4 and M1:e.5 and the rest between M1:10 and M1:12.

You access ControlNet data located in M1 and M0 files using the COP (copy) instruction in your ladder program. Since the maximum data length you can transfer with the COP instruction is 128 words, you need two instructions to copy the whole ControlNet area and control and status word in processor memory. If you have less than 128 words of data mapped in an M file, we recommend that you pack them together so that you can use a single copy instruction.

IMPORTANT

To ensure data consistency at the connection level, be sure that, for all connections configured, data of a same connection are copied into processor memory using a single copy instruction.

When you are building your mapping, we recommend that you save free space between device connections if the size of these connections may increase in the future.

Work with the ControlNet Explicit Message Instruction

What This Chapter Contains The following table describes what this chapter contains.

| For Information About | See Page |
|---|----------|
| ControlNet Explicit Message (CEM) Instruction Overview | 4-1 |
| How to Work with the Explicit Message Instruction | 4-2 |
| How to Work with the CEM Instruction Parameters | 4-2 |
| How to Work with the CEM Instruction Setup Screen Parameter | 4-3 |

Understand the ControlNet Explicit Message (CEM) Instruction

The CEM instruction lets generic Common Industrial Protocol (CIP) commands be initiated to devices, such as drives, communicating on ControlNet networks. This instruction requires RSLogix 500 software, version 7.10 or later, for programming.

The CEM instruction uses the explicit message capability built into the 1747-SCNR ControlNet scanner.

While not adding any additional capability over what already exists in the scanner, the CEM instruction simplifies the programming, configuration, monitoring, and troubleshooting of explicit messages on the ControlNet network.

Unlike I/O configured in the scanner's scan list, which is updated on a continual basis, explicit messages let data be sent and received on an as-needed basis, minimizing network traffic. For instance, you may want to write configuration parameters to a drive once at machine start-up time.

The CEM instruction can be used with any SLC 5/03, 5/04, or 5/05 processor that is at OS firmware level Series C, FRN 10, or later.

The CEM instruction uses an integer control block for storing the instruction parameters and a configuration setup screen, similar to the MSG instruction. The CIP commands consist of a Service Code; the object Class, Instance, and Attribute; and Send and Receive Data (if required for the selected Service Code). The setup screen provides a list of standard CIP Services to select from, including:

- Read Assembly.
- Write Assembly.
- Read Parameter.
- Write Parameter.
- Generic Get Attribute Single.
- Generic Set Attribute Single.

In addition, a Custom setting lets you enter any Service Code. Send data and receive data are stored in separate data table files.

Work with ControlNet Explicit Message (CEM)



| Fixed | SLC 5/01 | SLC 5/02 | SLC 5/03 | SLC 5/04 | SLC 5/05 |
|--------------------|----------|----------|----------|----------|----------|
| | | | • | • | • |
| Output Instruction | | | | | |

This is an output instruction that lets you initiate unconnected CIP Generic messages via a 1747-SCNR ControlNet scanner installed in the local chassis.

These messages can be initiated to any nodes on the same ControlNet network as the 1747-SCNR module, regardless of whether the destination node is in the scanner's scan list or not, and regardless of whether the scanner is in Run mode or Idle mode.

Each scanner can process only one CEM instruction at a time. The instruction is similar in operation to a standard MSG instruction.

CEM Instruction Parameters

Enter the following parameters when programming this instruction.

- Control Block is an integer file address that you select. It is a block of words, containing the status bits and other data associated with the CEM instruction.
- Control Block Length is a display-only field that indicates how many integer file words are being used by the control block. For the CEM instruction, the length is always 67 words.

CEM Instruction Setup Screen Parameters

Read these sections for information about the parameters for the CEM instruction setup screens.

Parameters for this controller on the general tab include the following.

- 1747-SCNR Slot

This drop-down field lists all of the local slots that contain ControlNet scanner (1747-SCNR) modules within the IO Configuration. Select the slot number of the particular scanner that this explicit message will be initiated through.

- Size in Words (Receive Data)

This field defines the size of the integer data file that will be used to store the data that is returned by this explicit message command. For best performance, define this file size to only be as large as is required. If no receive data is expected, you may leave this field at 0 and no receive data file will be defined. If unsure of how much data will be returned, you may select up to the maximum size of 250 words, and then reduce the size later based on experience.

- Size in Words (Send Data)

This field defines the size of the integer data file that will be used to store the data that is sent along with this explicit message command. For best performance, define this file size to only be as large as is required. If no send data is required, you may leave this field at 0 and no send data file will be defined. If unsure of how much data will be sent, you may select up to the maximum size of 248 words when defining the instruction, and then reduce the size later based on experience.

- Data Table Address (Send Data)

If Size in Words (Send Data) is non-zero, then this field requires a starting integer (N) file address for storing the Send Data.

- Data Table Address (Receive Data)

If Size in Words (Receive Data) is non-zero, then this field requires a starting integer (N) file address for storing the Receive Data.

Parameters for target device on the general tab include the following.

- Message Timeout (x1 ms)

The amount of time in milliseconds that the scanner will wait for a reply to the explicit message command. Range is 2 to 32767.

- ControlNet Addr (dec)

The target ControlNet node address. Valid range is 1 to 99. If you enter in the local scanner's ControlNet node address, the command is executed by the local scanner.

- Service

This pull-down menu lets you select services based on name rather than Service Code. The Custom service lets you enter any Service Code in the hexadecimal range of 1 to 7F. These services are listed in the pull-down selection.

- Read Assembly
- Write Assembly
- Write Output Point
- Read Output Point
- Read Input Point
- Read Parameter
- Write Parameter.
- Read Analog Input
- Write Analog Output
- Generic Get Attribute Single
- Generic Set Attribute Single
- Generic Get Member
- Generic Set Member
- Reset Identity Object
- Custom

- Service Code (hex)

This field is read-only unless the Custom Service is selected. Possible Service Codes are 1 to 7F (hex). See Volume 1 of the CIP Common Specification, Appendix A, for the list of valid explicit messaging Service Codes.

- Class (hex)/(dec)

Possible Classes are 0 to FF (hex). See Volume 1 of the CIP Common Specification for the list of defined Classes. You may either enter in a hexadecimal Class value in the (hex) field or a decimal Class value in the (dec) field.

- Instance (hex)/(dec)

Possible Instances are 0 to FFFF (hex). See Volume 1 of the CIP Common Specification for the list of valid Instances for each Class. You may either enter in a hexadecimal Instance value in the (hex) field or a decimal Instance value in the (dec) field.

- Attribute (hex)/(dec)

Possible Attributes are 0 to FFFF (hex). See Volume 1 of the CIP Common Specification for the list of valid Attributes for each Class. You may either enter in a hexadecimal Attribute value in the (hex) field or a decimal Attribute value in the (dec) field.

- Member (hex)/(dec)

Possible Members are 0 to FFFF (hex). See Volume 1 of the CIP Common Specification for the list of valid Members for each Class. You may either enter in a hexadecimal Member value in the (hex) field or a decimal Member value in the (dec) field.

Definitions for Message Status Bits on the General Tab

See the table that lists the various status bits associated with the CEM instruction as displayed in the CEM instruction setup screen.

| CEM Instruction Setup Screen Status Bit | | |
|--|---------------------|--------------------|
| Bit Definition | Bit Mnemonic | Bit Address |
| Timeout | TO | 08 |
| Error | ER | 12 |
| Done | DN | 13 |
| Enabled | EN | 15 |
| Waiting for slot | WS | 10 |

- Timeout bit TO (word 0, bit 8) is set when the scanner times out the message either due to no response from the target device or due to no reply being returned within the configured timeout period. The ER bit will be set at the same time the TO bit is set. This bit is reset the next time the message rung goes from false to true. Do not set or reset this bit. It is informational only.
- Error bit ER (word 0, bit 12) is set when the message has failed to complete successfully. This bit is reset the next time the message rung goes from false to true. Do not set or reset this bit. It is informational only.
- Done bit DN (word 0, bit 13) is set when the message has completed successfully. This bit is reset the next time the message rung goes from false to true. Do not set or reset this bit. It is informational only.
- Enabled bit EN (word 0, bit 15) is set after the message rung goes from false to true and the scanner accepts this message because it is not currently processing any other explicit messages. (The scanner can process only one CEM instruction at a time.) If the message rung goes false before the scanner accepts this message, then the enable bit will remain off and the message will not be executed. This bit is reset when the message has completed with either the Done bit set or the error bit set and the message rung goes false. If the message rung conditions remain true, you may retrigger the message instruction by resetting this bit after either the ER or DN bit has been set, indicating that the previous execution has completed.
- Waiting for Slot bit WS (word 0, bit 10) is set when the message rung goes from false to true, but the scanner is still processing another CEM instruction. To ensure that this message gets processed, you must leave the message rung conditions true until the WS bit is reset and the EN bit is set, indicating that the scanner has accepted this message for processing. Do not set or reset this bit. It is informational only.

Scanner Status, Error, and Error Description on the General Tab

The Scanner Code displays the explicit message status returned by the scanner. A scanner code of 0 means no errors. See the CEM Instruction Scanner Codes table for a list of other valid scanner codes.

CEM Instruction Scanner Codes

| Scanner Code | Description of Scanner Status |
|---------------------|--------------------------------------|
| 201H | Invalid command data size |
| 202H | Internal fault detected |
| 204H | Invalid service code |
| 205H | Invalid IOI size |
| 206H | Invalid CIP request block contents |
| 207H | CIP message request timeout |
| 208H | CIP timeout value too small |

A scanner code of 0x207 results in an error code of 1. All other scanner codes listed result in an error code of 2. The Valid CEM Instruction error codes table lists all valid CEM instruction error codes.

Valid CEM Instruction Error Codes

| Error Code | Description of Error Condition |
|------------|--|
| 0 | No error. |
| 1 | Timeout error. ControlNet explicit message timed out by scanner. |
| 2 | Scanner error. See Scanner Status. |
| 3 | Configuration error. Send file length > 248 or invalid IOI size. |
| 5 | Processor error. Invalid response. |
| 6 | Processor error. Unsolicited response received. |
| 7 | Configuration error. Size of response data > receive data size. |

For error code 4, the error description displays the CIP response error code and description as documented in the CIP Common Specification, Appendix B.

Any time the Error code is non-zero, the CEM error (ER) bit is set.

Send Data Tab

The Send Data Tab provides a convenient way of viewing and entering in data to be sent along with the explicit message command. The data is shown in byte format with a selectable radix of either Decimal or Hex/BCD. The display only shows the number of words that are defined in the Size in Words (Send Data) field, starting with the low byte of the first word as defined in the Data Table Address (Send Data) field. If the Size in Words is zero, then no data is displayed. You can also change the data being viewed, but only when offline or during an online edit. Click on the data and enter in a byte value based on the current radix (0 to 255 for Decimal and 0 to FF for Hex/BCD). The changed data gets copied to the Send Data data table file when the rung is accepted. To update the Send Data display with the current values stored in the Send Data data table file, click on the Refresh button.

Receive Data Tab

The Receive Data Tab provides a convenient way of viewing the data that is returned by the target device in response to the explicit message command sent. The data is shown in byte format with a selectable radix of either Decimal or Hex/BCD. The display only shows the number of words that are defined in the Size in Words (Receive Data) field, starting with the low byte of the first word as defined in the Data Table Address (Receive Data) field. If the Size in Words is zero, then no data is displayed. To update the Receive Data display with the current values stored in the Receive Data data table file, click on the Refresh button.

Control Block Layout

See this table for the control block layout.

SLC 5/0x ControlNet Explicit Message (CEM) Control Block Structure

| | 15 | 14 | 13 | 12 | 11 | 10 | 09 | 08 | 07 | 06 | 05 | 04 | 03 | 02 | 01 | 0 |
|---------|--|----|----|----|----|----|----|----|----------------------------------|----|----|----|----|----|----|---|
| Word 0 | EN | | DN | ER | | WS | | TO | Reserved by the 1747-SCNR module | | | | | | | |
| Word 1 | Target MAC ID | | | | | | | | | | | | | | | |
| Word 2 | Message Timeout Preset (x1 ms) | | | | | | | | | | | | | | | |
| Word 3 | Complex IOI Size | | | | | | | | | | | | | | | |
| Word 4 | Reserved | | | | | | | | Service Code | | | | | | | |
| Word 5 | Reserved | | | | | | | | Class | | | | | | | |
| Word 6 | Instance | | | | | | | | | | | | | | | |
| Word 7 | Attribute | | | | | | | | | | | | | | | |
| Word 8 | Member | | | | | | | | | | | | | | | |
| Word 9 | Size of Command Data (Words) | | | | | | | | | | | | | | | |
| Word 10 | Request Status - Scanner Status (Scanner Code) | | | | | | | | | | | | | | | |
| Word 11 | Response Status | | | | | | | | | | | | | | | |
| Word 12 | Extended Status Size (Words) | | | | | | | | | | | | | | | |
| Word 13 | Size of response and status (Words) | | | | | | | | | | | | | | | |
| Word 14 | Complex IOI Buffer (Lets you to manually set IOI) | | | | | | | | | | | | | | | |
| ----- | | | | | | | | | | | | | | | | |
| Word 63 | | | | | | | | | | | | | | | | |
| Word 64 | Error Code | | | | | | | | Transaction ID | | | | | | | |
| Word 65 | Extended Status Debug Word 1 | | | | | | | | | | | | | | | |
| Word 66 | Extended Status Debug Word 2 | | | | | | | | | | | | | | | |

Troubleshoot

What This Chapter Contains The following table describes what this chapter contains and its location.

| For Information About | See Page |
|------------------------------------|----------|
| Troubleshooting | 4-1 |
| Apply chassis power | 4-2 |
| Alphanumeric display | 4-2 |
| OK indicator and display mnemonics | 4-3 |

Troubleshoot with the Status Indicators and Status Display

The 1747-SCNR module has indicators on the front plate, as shown in the figure.

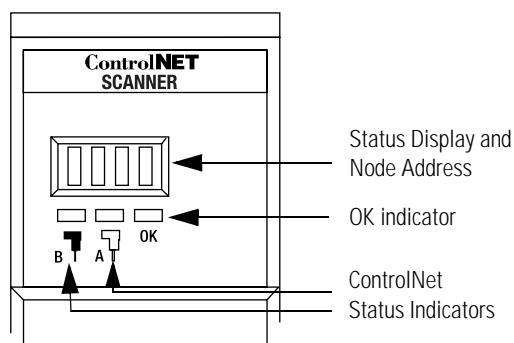

30750-M

These indicators are the following.

- An alphanumeric display (of status and node address)
- A and B status indicators
- OK

Use these indicators to troubleshoot the scanner.

Apply Chassis Power

When you apply chassis power, the module address and status display cycles through the following mnemonics:

1. **POST** - The 1747-SCNR runs Power On Self Test.
2. **1111, 2222, etc.** - The 1747-SCNR is executing its startup sequence.
3. The 1747-SCNR firmware version is displayed temporarily after startup.
4. **A#nn** (where nn = ControlNet node address) then **I/OI** or **I/OX** (based on the number of connections configured and established) then **IDLE** or **RUN** (based on the scanner mode).

Alphanumeric Display

The four character alphanumeric display provides you with additional visual information about the current operational status of the module.

See the tables that describe problems that may occur while using your 1747-SCNR module, the probable causes, and the recommended action.

OK Indicator and Display Mnemonics

The OK indicator is handled consistently with the ControlNet specifications for the Identity object.

| Sequence | OK Indicator | Alphanumeric Display | Module Status Word (M1 file) | Description | Probable Cause | Recommended Action |
|----------|-----------------------|----------------------|------------------------------|--|---|--|
| Startup | Alternating red/green | POST | N/A | The 1747-SCNR module is running Power On Self Test. | Power was applied to the module. | No action required. |
| | | FIRMWARE | N/A | 1747-SCNR firmware revision. This is a temporary display after start up. | Power was applied to the module. | No action required. |
| Run time | Green | A#XX | N/A | ControlNet node address | None | No action required. |
| | | I/O ■ | 0x26 | All configured connections are established. | None | No action required. |
| | | IDLE | N/A | The scanner is in idle mode. | The SLC processor in slot 0 is in program mode or the Scanner Mode Command bit of the Module Command word is clear (O:e.0/10 where e is the scanner slot number). | If you want to put the scanner into run mode, put the SLC processor in slot 0 into run mode and set the Scanner Mode Command bit of the Module Command word (O:e.0/10) using an unconditional OTE instruction. |
| | | RUN | N/A | The scanner is in run mode. | The SLC processor in slot 0 is in run mode and the Scanner Mode Command bit of the Module Command word is set (O:e.0/10). | If you want to put the scanner into program mode, either put the SLC processor in slot 0 into program mode or clear the Scanner Mode Command bit of the Module Command word (O:e.0/10). |
| | | EDIT | N/A | The scanlist in the 1747-SCNR is being modified. | Edits have been enabled with RSNetWorx for ControlNet software. Note that previously configured connections will be reestablished if lost. Newly configured or changed connections will not be established until edits are accepted. | Finish modifying the scanlist with RSNetWorx for ControlNet software and then accept edits. Cancel edits with RSNetWorx for ControlNet software. |





| Sequence | OK Indicator | Alphanumeric Display | Module Status Word (M1 file) | Description | Probable Cause | Recommended Action |
|----------|----------------|----------------------|------------------------------|---|--|--|
| Run time | Flashing Green | I/OX | 0x20 | The scanner is not configured. | Module is not configured. | Use RSNetWorx for ControlNet software to download a new configuration. |
| | | | 0x21 | The current configuration is not valid. The scanner is not able to start any scheduled communication to remote devices. Only unscheduled communication is possible. | Module is not configured properly. | Use RSNetWorx for ControlNet software to schedule the existing configuration. Use RSNetWorx for ControlNet software to download a new configuration. |
| | | I/O □ | 0x22 | Connections are configured but no connections are established. | View the Connection Status screen in RSNetWorx for ControlNet software to see why the connections are not established. | Check to see if the 1747-SCNR and the remote devices are correctly connected to the ControlNet network. |
| | | I/O ▣ | 0x23 | Connections are configured but only 25% are successfully established. | Module bandwidth is exceeded. | Reduce the number of scheduled connections by: - using a discrete rack connection instead of multiple discrete module connections - combining multiple I/O racks into a single I/O rack - combining multiple peer-to-peer messages into one message. Increase your Network Update Time and/or increase the Requested Packet Intervals for scheduled data transfers. Increase your SLC 500 ladder program scan by adding more logic. |
| | | I/O ▤ | 0x24 | 50% | | |
| | | I/O ▥ | 0x25 | 75% | | |
| | | | EDIT | N/A | The scanlist in the 1747-SCNR module is being modified. | Edits have been enabled with RSNetWorx for ControlNet software. Note that previously configured connections will be reestablished if lost. Newly configured or changed connections will not be established until edits are accepted. |

| Sequence | OK Indicator | Alphanumeric Display | Module Status Word (M1 file) | Description | Probable Cause | Recommended Action |
|----------|----------------|---|------------------------------|--|---|---|
| Run time | Flashing Green | SIGM | N/A | A scanner signature mismatch has been detected. The 1747-SCNR scanner signature does not match the signature stored in the active keeper. The scanner is not able to start any scheduled communication to remote devices. Only unscheduled communication is possible. | Module is not configured properly. | Use RSNetWorx for ControlNet software to schedule the existing configuration. Use RSNetWorx for ControlNet software to download a new configuration. |
| Errors | Off | None | N/A | Module is not communicating. | Power supply fault. | Check power supply, cable connectors, and seat module firmly in chassis. |
| | Flashing Green | N/A | 0x43 | Network error. | Cable error or no other nodes on the network. | Verify network cabling. |
| | Red | (Scrolling display showing fault details) | N/A | Module faulted. | Internal error detected. | Record fault details and contact Rockwell Automation representative or distributor. |
| | Flashing Red | A#00 FLSH CFG ERAS | 0x42 | Module erased network and connection configuration stored in flash. | Network node address is set to 00. | Power down the module and change the address switches. |
| | | DUPL A#XX | 0x44 | Duplicate node address. | Another device with the same ControlNet address is on the link. | Power down the 1747-SCNR module and change the network address switches to a correct node. |

ControlNet Status indicators may behave in these ways and display these additional color schemes as described:

- Steady – indicator is on continuously in the defined state.
- Alternating – the two indicators alternate between the two defined states at the same time (applies to both indicators viewed together). The two indicators are always in opposite states (out of phase).
- Flashing – the indicator alternates between the two defined states (applies to each indicator viewed independent of the other). If both indicators are flashing, they must flash together (in phase).

See the table that describes how the status indicator is behaving, the cause of the behavior, and the action you should take.

| A  and B  | Probable Cause | Recommended Action |
|---|---|---|
| Off | No power | No action required or apply power. |
| Steady red | Faulty unit | Cycle power or reset unit. If fault persists, contact a Rockwell Automation representative or distributor. |
| Alternating red/green | Self-test | No action required. |
| Alternating red/off | Incorrect node configuration or duplicate ControlNet node address | Check network address and other ControlNet configuration parameters. |
| A  or B  | Probable Cause | Recommended Action |
| Off | Channel disabled | Program network for redundant media, if required. |
| Steady green | Normal operation | No action required. |
| Flashing green/off | Temporary network errors | <ul style="list-style-type: none"> Check media for items such as broken cables, loose connectors, and missing terminators. |
| Flashing red/off | Media fault | <ul style="list-style-type: none"> Check media for broken cables, loose connectors, missing terminators, etc. |
| | No other nodes present on the network | Add other nodes to the network. |
| Flashing red/green | Incorrect node address | Change 1747-SCNR node address so that it is less than or equal to SMAX. ⁽¹⁾ |
| | Incorrect network configuration | Reconfigure ControlNet network so that SMAX ¹ is greater than or equal to 1747-SCNR node address. |

⁽¹⁾ SMAX is the highest node address on a ControlNet network that can transmit scheduled data.

Local Database Access Using PLC-5 MSG Instructions

What This Appendix Contains

This appendix describes how a PLC-5 processor reads or writes data in the 1747-SCNR module Local Database using the message (MSG) instruction.

What We Assume

We assume that you know how to use the PLC-5 Message ladder instruction.

Read and Write Access To 1747-SCNR Local Database Using PLC-5 MSG Instruction

The Local Database is used for direct read or write access from the network. A remote PLC-5 processor can access this database with MSG instruction as described below.

The PLC-5 processor can read or write data in the 1747-SCNR Local Database with the Message instruction. This instruction creates unscheduled message connections that are initiated by the PLC-5 processor and sent to the 1747-SCNR processor.

The 1747-SCNR scanner supports up to 50 simultaneous unscheduled connections.

PLC-5 MSG instruction contains the following information:

- Command – Only PLC-5 Typed Read, PLC-5 Typed Write, PLC-2 Unprotected Read, and PLC-2 Unprotected Write are supported by the 1747-SCNR
- Data-table address in PLC-5 source processor
- Size of message in elements
- Network address of destination processor

- Data-table address in destination processor - The destination file must be N7, otherwise the request will be rejected.
 - PLC-5 Typed Read and PLC-5 Typed Write: N7:XX where XX is the zero-based element offset in the Local Database file
 - PLC-2 Unprotected Read, PLC-2 Unprotected Write: YY where YY is the octal zero-based element offset in the Local Database file
- Port number - set to 2 for the ControlNet network
- Flags:
 - .TO - forces a message to timeout
 - .EW - indicates that the message is waiting for an open connection
 - .CO - indicates that the message is sent
 - .ER - indicates that the message was terminated due to an error
 - .DN - indicates that the message was sent without error
 - .ST - indicates that the message was started
 - .EN - indicates that the message instruction is enabled
- Error code - indicates the error when the .ER is set

For each concurrently enabled MSG instruction, the PLC-5 processor opens an unscheduled connection.

All messages sent over different connections to the 1747-SCNR scanner have the same priority.

The following example illustrates how a PLC-5 ladder program can read or write the 1747-SCNR Local Database using the MSG instruction. The steps in this process correspond to the steps in the illustrations.

1. The ladder programmer inserts a MSG instruction into the ladder program.
2. This message instruction sends five words from the PLC-5 N7 data file, starting at offset 0, to remote 1747-SCNR Local Database file offset 10 (N7:10). The destination node is 22.
3. The PLC-5 processor is put into RUN mode. Then the PLC-5 processor opens an unscheduled connection to the 1747-SCNR module and messages are exchanged.
4. The SLC 500 ladder program reads 20 words of 1747-SCNR Local Database in slot 0 offset 700: #M0:1.700.
5. Elements from the PLC-5 N7 file are available in the SLC 500 N11 file, starting at address N11:10.

IMPORTANT

When the #M0.e.yyyy address is used in ladder instructions, e is the 1747-SCNR slot number in the SLC rack. If you reuse this example, and your module is not in slot number one, update all instructions with the current appropriate number.

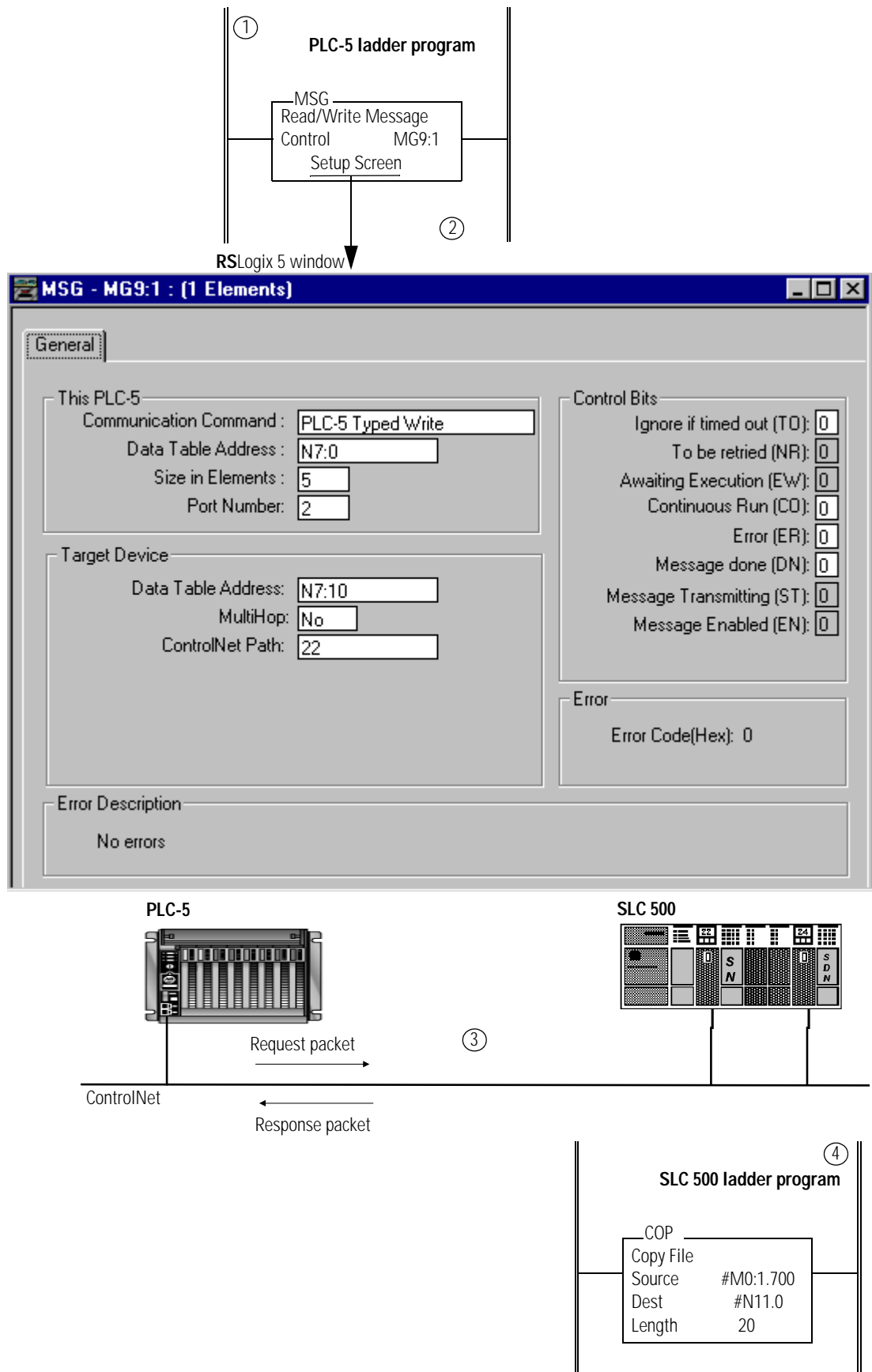

⑤ **PLC-5 Processor - Sources: N7 Data File**

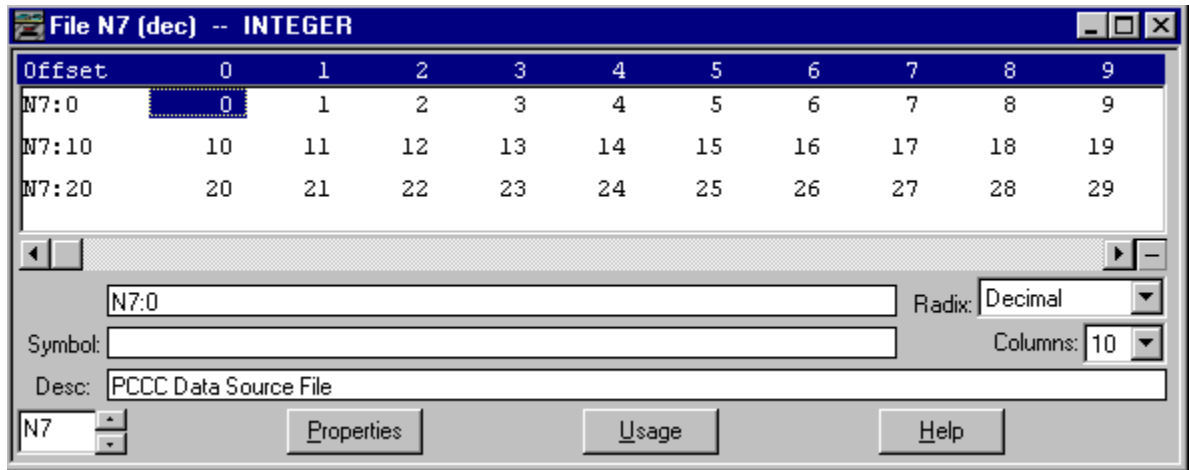

SLC 500 Processor - Destination: N11 Data File
 RSLogix 500 window

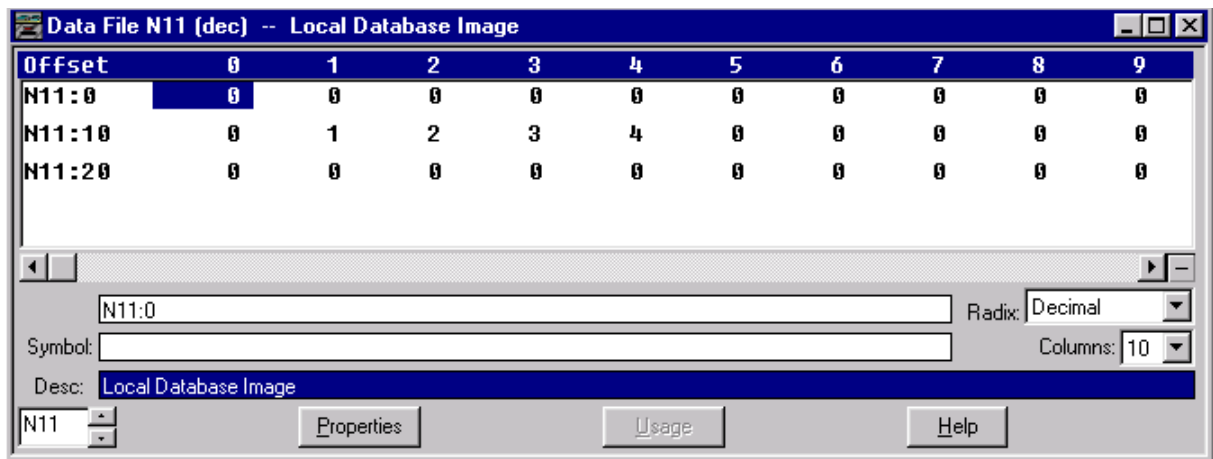

Notes:

Use CIP Messaging to Access Local Database and ControlNet Data Files

What This Appendix Contains

This appendix provides a description of how a remote device can read or write the Local Database and ControlNet data areas of the 1747-SCNR scanner by using Get Member and Set Member services. These data files are located in Input, Output, M0 and M1 memory files.

What We Assume

We assume that you are familiar with object modeling and CIP protocol as described in the ControlNet Specification available from ControlNet International. You can contact ControlNet International at its website www.controlnet.org.

Read and Write Access to 1747-SCNR Data Files Using Assembly Object Services

The 1747-SCNR scanner supports the following aspects of Assembly Object Services:

- The 1747-SCNR assembly object supports Get Member and Set Member services. The IOI of these requests must contain four logical segments: Class number, instance number, attribute number and member number.
- The member number is interpreted as the one-based word offset of the data transfer.
- The number of members (first word of the request field) is interpreted as size in words of the data transfer.

Assembly Object Instance Numbers Supported for Get and Set Member on Data Attribute

The following table lists assembly object instance numbers supported for Get and Set Member services.

| SLC File | Word Offset | Contents | Assembly Object Instance Number | Member Number Range |
|----------|-------------|------------------------|---------------------------------|---------------------|
| Input | 0...31 | ControlNet Input Data | 6 | 1...32 |
| Output | 0...31 | ControlNet Output Data | 5 ⁽¹⁾ | 1...32 |
| M1 | 0...607 | ControlNet Input Data | 8 | 1...608 |
| M0 | 0...1650 | ControlNet Output Data | 7 | 1...1651 |

⁽¹⁾ Instance 5 does not support Set Member service (no write access).

These rules apply to all Set Member or Get Member services on the Assembly Object.

- Set Member and Set Attribute services on the discrete Input data file are rejected if the SLC processor is in Run mode (no write access).
- Set Member and Set Attribute services on the discrete Output data file are always rejected (no write access).
- Set Member and Set Attribute services on the M0 and M1 files are always accepted (regardless of SLC processor mode).

See the table that contains examples of valid and invalid range of values for Instance Number, Member Number, and Size Parameter.

| | | Get Member | Set Member |
|----------------|---|---|--|
| Valid | Instance Number = 0x08 Member Number = 0x01 Size Parameter = 0x01 | The 1747-SCNR scanner returns the first word of the Local Database file [M0:0]. | The 1747-SCNR scanner writes 1 word of data into the first word of the Local Database file [M0:0]. |
| | Instance Number = 0x08 Member Number = 0x012D Size Parameter = 0x14 | The 1747-SCNR scanner returns 20 words of the Local Database file starting with one-based word offset of 301(dec) [M0:300]. | The 1747-SCNR scanner writes the 20 words of data into the Local Database file starting at the one-based word offset of 301(dec) [M0:300]. |
| | Instance Number = 0x05 Member Number = 0x01 Size Parameter = 0x02 | The 1747-SCNR scanner returns 2 words of data starting from I:1. | The 1747-SCNR scanner writes 2 words of data starting at I:1. |
| Invalid | Instance Number = Any Member Number = 0x00 Size Parameter = 0x02 | 0 is an invalid member number. Request rejected. | 0 is an invalid member number. Request rejected. |

1747-SCNR Memory Layout See the figure for an example of 1747-SCNR memory layout.

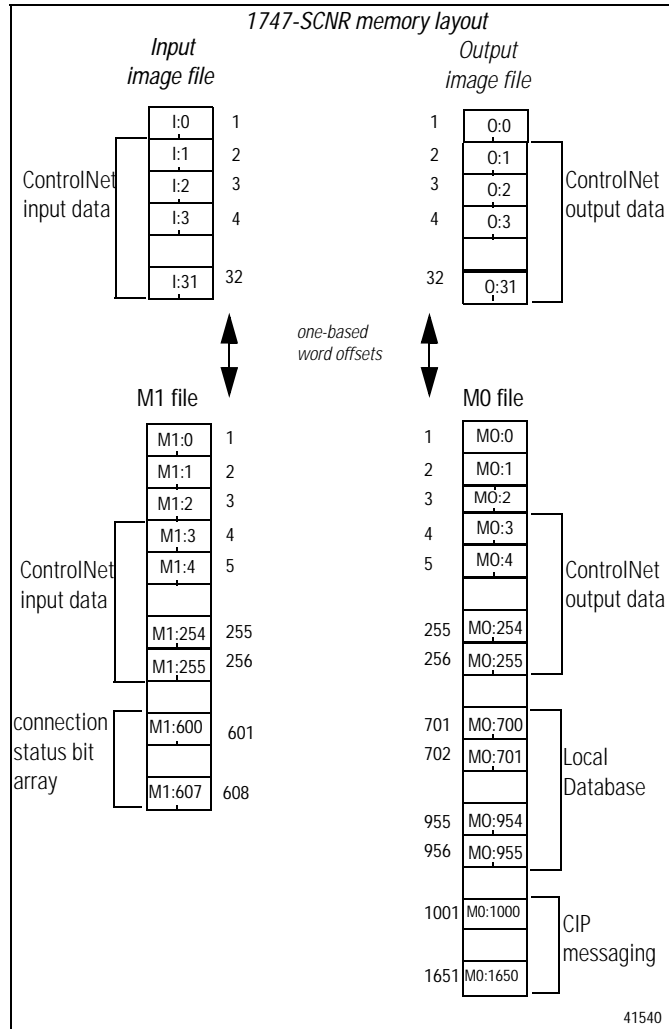

CIP Client Management

What This Appendix Contains

This appendix contains an example of how you can manage the CIP Client area to issue a CIP client request to a remote node on the ControlNet network.

What We Assume

We assume that you are familiar with the following.

- Ladder programming
- Object modeling as described in ControlNet specifications, noting that you can contact ControlNet International at its website www.controlnet.org, if needed

CIP Client Area

The 1747-SCNR M0 file contains a CIP client area that can be used to let limited unconnected data exchange with a remote node on the local ControlNet link. These messages are initiated by the SLC processor.

The 1747-SCNR module processes CIP client requests when the SLC processor is in Run mode, regardless of the state of the Scanner Mode bit of the Module Command word (O:e0/10). CIP client requests are not processed when the SLC processor is in Program mode.

The message is built by ladder programming using the structure described in the table.

| M0 File Word Offsets | Word Size | Contents | Description |
|----------------------|-----------|---------------------|--|
| 1000 | 1 | CIP Message Control | These bits are similar to the MSG bits from the SLC 500 instruction set. Bit 0-7: Reserved Bit 8: TO -Timeout on message sent Bit 9: unused (NR) Bit 10: EW -Message taken into account by 1747-SCNR, waiting for a response Bit 11: CO -Continuous mode Bit 12: ER -Error returned by the 1747-SCNR Bit 13: DN -Response received Bit 14: unused (ST) Bit 15: EN -Message enable. |
| 1001 | 1 | Target MAC ID | Destination node address. |
| 1002 | 1 | Timeout | The scanner will wait this number of ms for a response. Must be nonzero, typical range 200-500 ms. |
| 1003 | 1 | Complex IOI size | The number of words from Complex IOI Buffer to be sent in the CIP message. If null, a default IOI is built from words 1004 through 1008. If non-null, this many words from 1050 through 1099 will be used for the IOI. |
| 1004 | 1 | Service code | Any value in the 0x01 to 0x7F range will be sent by the 1747-SCNR module as a valid service code. If the Object attribute code is non-null, the IOI will contain the class and instance logical segments. If the attribute code is non-null, the IOI will also contain the attribute logical segment. Any other value will generate an error and no service will be sent on the wire. Refer to the ControlNet International Specification for valid service codes. ⁽¹⁾ |
| 1005 | 1 | Object class code | Destination object class number. First IOI logical segment. This field must be non-null. |

1. You can purchase the ControlNet International Specification from ControlNet International.

| M0 File Word Offsets | Word Size | Contents | Description |
|----------------------|-----------|---------------------------------|---|
| 1006 | 1 | Object instance code | Destination object instance number. |
| 1007 | 1 | Object attribute code | Destination object attribute number. Can be null if attribute logical segment is not required. |
| 1008 | 1 | Object member code | Destination object member number. Can be null if member logical segment is not required. |
| 1009 | 1 | Size of command data | Size in words of command data in the following area. This field must be null when no command data are sent. |
| 1010-1019 | 1 | Reserved | Must be set to zero or undefined behavior may result. |
| 1020 | 1 | Request message status | Error code generated by 1747-SCNR when attempting to send request (0 means no error). 0x201:Invalid command data size in word 1009 0x202:Internal fault 0x204:Invalid service code in word 1004 0x205:Invalid IOI data size in word 1003 0x206:Invalid CIP request block contents 0x207:CIP message request timeout 0x208:CIP timeout value too small in word 1002 |
| 1021 | 1 | General status response | Status returned by CIP response message (0 means no error). Refer to the ControlNet International Specification for valid general status codes ⁽¹⁾ . |
| 1022 | 1 | Extended status size | Extended status size in the following response area. This value is zero, if unused. |
| 1023 | 1 | Size of response and status | Size in words of the response returned by the 1747-SCNR scanner in the Extended status and Response data area. |
| 1024-1049 | 1 | Reserved | Must be set to zero or undefined behavior may result. |
| 1050-1099 | 50 | Complex IOI buffer | Data values are copied into a CIP message path segments. |
| 1100-1349 | 250 | Command data | Request data. |
| 1350-1600 | 251 | Extended status + Response data | Response data. |

⁽¹⁾ You can purchase the ControlNet International Specification from ControlNet International.

Send a Get Attribute All Request to Node 14 Identity Object

In this example, a 1747-SCNR module with MAC ID 11 is located in slot 1 of the SLC rack. It sends a Get Attribute All request to the Identity object of a remote 1794-ACNR15 Flex I/O device at MAC ID 14 on the ControlNet network. This request is triggered by the ladder program using the CIP Client feature provided by the 1747-SCNR module.

This process is illustrated in the following example. The steps in the procedure correspond to the steps in the illustrations.

1. The CIP message control image is updated on a regular basis.
2. The message and its data are prepared in the SLC N7 file to be copied in M0 using a single COP (copy) instruction. To send the message, first clear the CIP message control image area in the SLC 500 N7 data file. No command data is needed for a Get Attribute Single request. Initialize the local CIP control words and data size. Set the EN bit and then copy the control data.
3. Request and response are exchanged on the wire.
4. When the DN bit is set without errors or timeout, copy the response data into an intermediate file and unlatch the DN bit.

The response is available in an SLC internal data file.

① SLC 500 Processor: N7 Data File (hex)

RSLogix 500 window

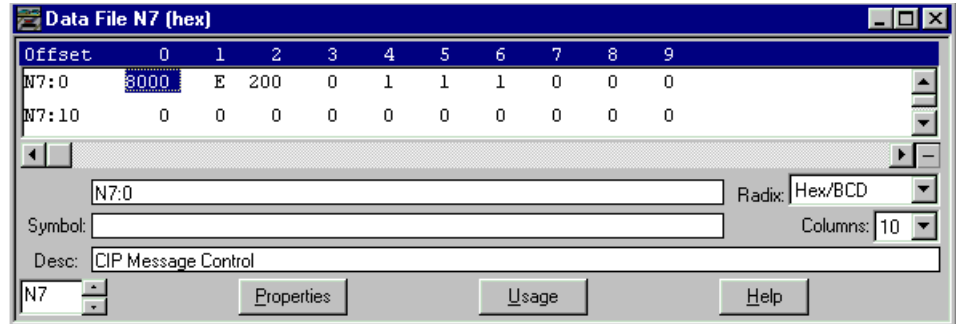

Detail:

N7:0 = 0x8000:Control word with EN bit set
 N7:1 = 0x0E:Target MAC ID - Node 14
 N7:2 = 0x200:Timeout 512 ms
 N7:3 = 0x0:Complex IOI size - Not used
 N7:4 = 0x01:Get Attribute All service code
 N7:5 = 0x01:Target Class code - Identity object class
 N7:6 = 0x01:Target Instance number - Instance number 1
 N7:7 = 0x00:Target Attribute number - Not used
 N7:8 = 0x00:Target Member number - Not used
 N7:9 = 0x00:Command Data Size - No data used

In the following ladder example:

M0:1.1100 = 0x00:Not used

SLC 500 Ladder Program

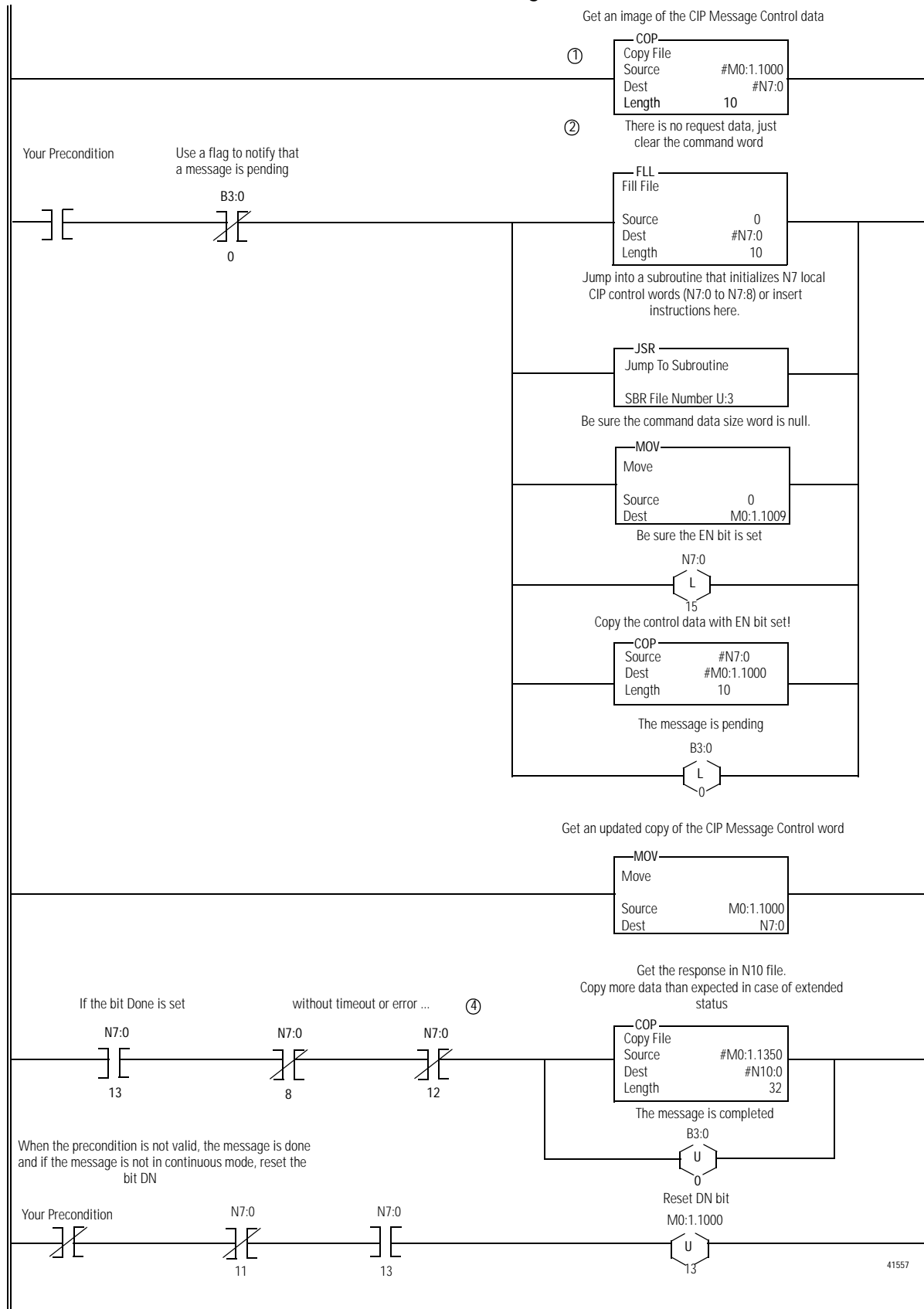

⑤ SLC 500 Processor: Data Files (hex)

N7:Message control image

RSLogix 500 window

| Offset | 0 | 1 | 2 | 3 | 4 | 5 | 6 | 7 | 8 | 9 |
|--------|------|---|-----|----|---|---|---|---|---|---|
| N7:0 | A000 | E | 200 | 0 | 1 | 1 | 1 | 0 | 0 | 0 |
| N7:10 | 0 | 0 | 0 | 0 | 0 | 0 | 0 | 0 | 0 | 0 |
| N7:20 | 0 | 0 | 0 | 18 | 0 | 0 | 0 | 0 | 0 | 0 |
| N7:30 | 0 | 0 | 0 | 0 | 0 | 0 | 0 | 0 | 0 | 0 |

Symbol: Radix: Hex/BCD
 Desc: CIP Message Control
 Columns: 10

Buttons: Properties, Usage, Help

Detail:

N7:0 = 0xA000:Control word with bits EN and DN set - Response received

N7:23 = 0x18:Response length - 24 words

N10:Response data

RSLogix 500 window

| Offset | 0 | 1 | 2 | 3 | 4 | 5 | 6 | 7 | 8 | 9 |
|--------|------|------|------|------|------|------|------|------|------|------|
| N10:0 | 1 | C | 25 | 202 | 30 | F4D7 | 4 | 3120 | 3937 | 2D34 |
| N10:10 | 4341 | 524E | 3531 | 4920 | 4F2F | 4120 | 6164 | 7470 | 7265 | 2020 |
| N10:20 | 2020 | 2020 | 6951 | 31 | 0 | 0 | 0 | 0 | 0 | 0 |
| N10:30 | 0 | 0 | 0 | 0 | 0 | 0 | 0 | 0 | 0 | 0 |

Symbol: Radix: Hex/BCD
 Desc: First Response Data
 Columns: 10

Buttons: Properties, Usage, Help

Detail:

N10:0 to N10:23:Response data

IMPORTANT

The data format on the wire is Little Endian. RSLogix 500 software displays words so byte order is inverted on the screen.

Send a Set Attribute Single Request

This process is illustrated in the following example. The steps in the process correspond to the steps in the illustrations following.

1. The CIP message control image is updated on a regular base.
2. You want to send a Set Attribute Single to Data Attribute (Attribute number 3) of assembly instance 6 (Input file words 1 to 32). The CIP message control area and command data are initialized in an internal data file. The command data is copied in M0 first, then the command word is cleared and, as a last step, the message control area is copied into M0 with the EN bit set to what will send the message on the wire.
3. Request and response are exchanged on the wire.
4. When the bit DN is set without an error or timeout, n latch the DN bit. No response data is expected in case of a successful response.

The response is available in an SLC internal data file.

See the following list for assembly object instance numbers supported by the Get and Set Attribute Single services on Data attribute.

Instance 5 : Output file words 1 to 32

Instance 6 : Input file words 1 to 32

SLC 500 Processor: N7 Data File (hex)

RSLogix 500

| Offset | 0 | 1 | 2 | 3 | 4 | 5 | 6 | 7 | 8 | 9 |
|--------|------|----|-----|----|----|----|----|----|----|----|
| N7:0 | 8000 | 8 | 200 | 0 | 10 | 4 | 6 | 3 | 0 | 20 |
| N7:10 | 1 | 2 | 3 | 4 | 5 | 6 | 7 | 8 | 9 | A |
| N7:20 | B | C | D | E | F | 10 | 11 | 12 | 13 | 14 |
| N7:30 | 15 | 16 | 17 | 18 | 19 | 1A | 1B | 1C | 1D | 1E |
| N7:40 | 1F | 20 | 0 | 0 | 0 | 0 | 0 | 0 | 0 | 0 |
| N7:50 | 0 | 0 | 0 | 0 | 0 | 0 | 0 | 0 | 0 | 0 |

Symbol: N7:0 Radix: Hex/BCD
 Desc: CIP Message Control Columns: 10

Detail:

- N7:0 = 0x8000:Control word with bit EN set
- N7:1 = 0x08:Target MAC ID - Node 8
- N7:2 = 0x200:Timeout 512 ms
- N7:3 = 0x0:Complex IOI size - Not used
- N7:4 = 0x10:Set Attribute Single service code
- N7:5 = 0x04:Target Class code - Assembly object class
- N7:6 = 0x06:Target Instance number - Instance 6: Input File
- N7:7 = 0x03:Target Attribute number - Data Attribute
- N7:8 = 0x00:Target Member number - Not used
- N7:9 = 0x20:Command Data size - 32 words of data at M0:1.1000
- N7:10 to N10:40:Data - Copy 32 words of data to M0:1.1000

⑤ Example: SLC 500 Ladder Program

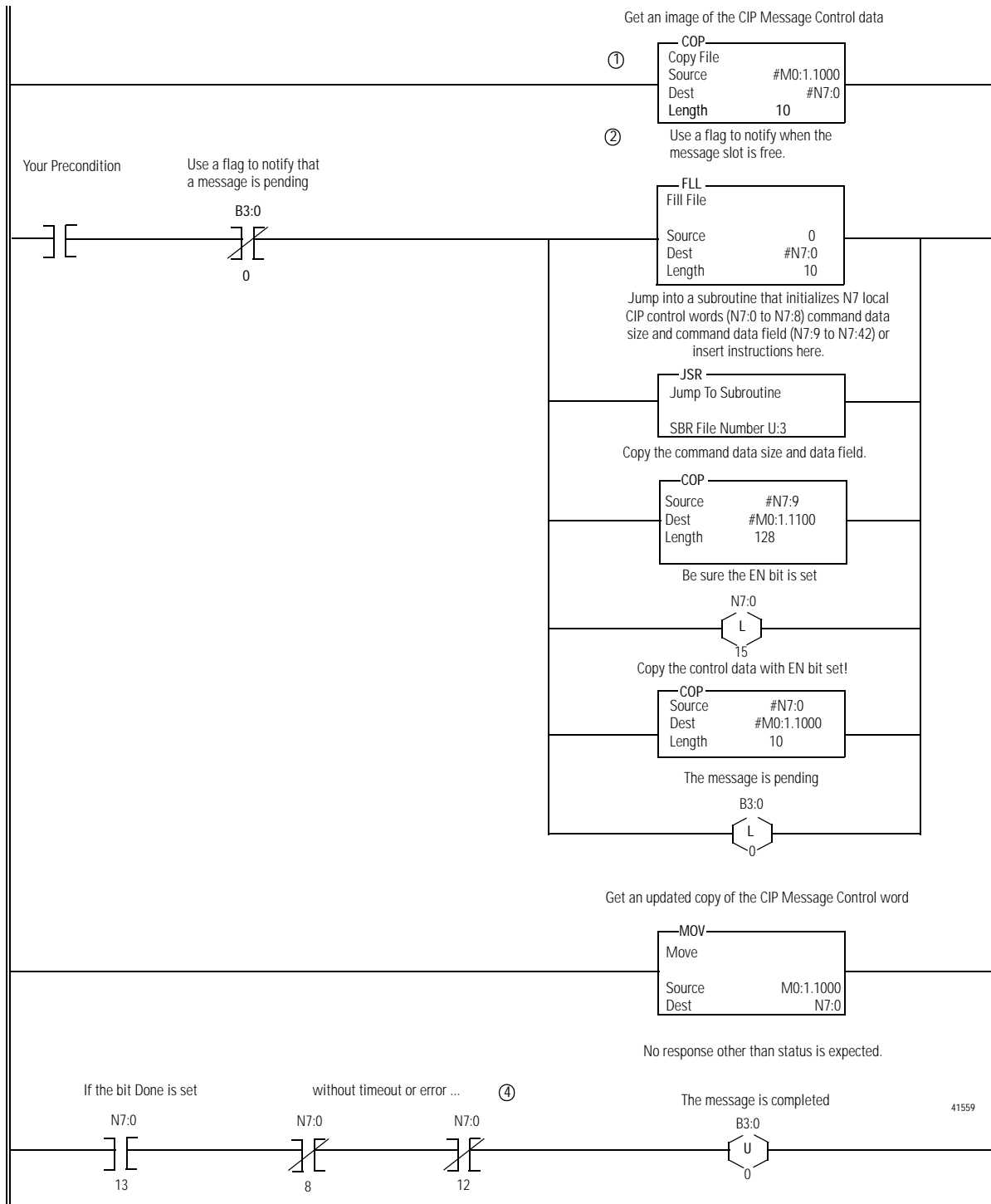

IMPORTANT

When the #M0.e.yyyy address is used in ladder instructions, e is the 1747-SCNR slot number in the SLC rack. If you reuse this example, and your module is not in slot number one, update all instructions with the current appropriate number..

SLC 500 Processor: Target Input Data File (hex)

RSLogix 500

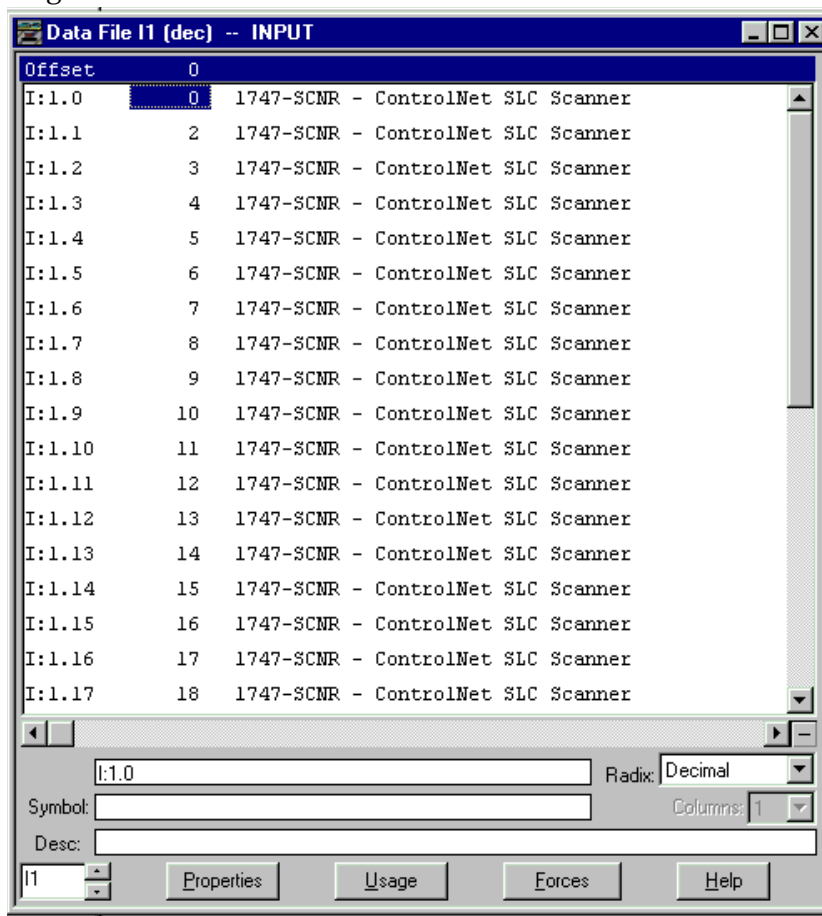

I:1 file is the image of target node 8 Input file.

The 1747-SCNR at MAC ID 11 wrote 32 words into the input data file of 1747-SCNR at MAC ID 8.

IMPORTANT

The 1747-SCNR module at MAC ID 8 must be in program mode to write to the input data file.

Send a Set Member Request

This process is illustrated in the following example. The steps in the What's Happening box correspond to the steps in the illustrations following the What's Happening box.

1. The CIP message control image is updated on a regular base.
2. You want to send a Set Member to Data Attribute (Attribute number 3) of assembly instance 7 (Local Database at words M0:701 to M0:956). The CIP message control area and command data are initialized in an internal data file. The command data is copied in M0 first, then the command word is cleared and, as a last step, the message control area is copied into M0 with the EN bit set to what will send the message on the wire.
3. Request and response are exchanged on the wire.
4. When the bit DN is set without an error or timeout, nlatch the DN bit. No response data is expected in case of a successful response.

The response is available in an SLC internal data file.

See the following list for assembly object instance numbers supported by the Get and Set Attribute Single services on Data attribute.

Instance 5 : Output file words 1 to 31

Instance 6 : Input file words 1 to 31

Instance 7 : M0, ControlNet Data area words 0 to 1650

Instance 8 : M1, ControlNet Data area words 0 to 607

SLC 500 Processor: N7 Data File (hex)

RSLogix 500

| Offset | 0 | 1 | 2 | 3 | 4 | 5 | 6 | 7 | 8 | 9 |
|--------|------|----|-----|----|----|----|----|----|-----|----|
| N7:0 | 8000 | 8 | 200 | 0 | 19 | 4 | 7 | 3 | 2BD | 41 |
| N7:10 | 40 | 1 | 2 | 3 | 4 | 5 | 6 | 7 | 8 | 9 |
| N7:20 | A | B | C | D | E | F | 10 | 11 | 12 | 13 |
| N7:30 | 14 | 15 | 16 | 17 | 18 | 19 | 1A | 1B | 1C | 1D |
| N7:40 | 1E | 1F | 20 | 21 | 22 | 23 | 24 | 25 | 26 | 27 |
| N7:50 | 28 | 29 | 2A | 2B | 2C | 2D | 2E | 2F | 30 | 31 |
| N7:60 | 32 | 33 | 34 | 35 | 36 | 37 | 38 | 39 | 3A | 3B |
| N7:70 | 3C | 3D | 3E | 3F | 40 | 0 | 0 | 0 | 0 | 0 |
| N7:80 | 0 | 0 | 0 | 0 | 0 | 0 | 0 | 0 | 0 | 0 |
| N7:90 | 0 | 0 | 0 | 0 | 0 | 0 | 0 | 0 | 0 | 0 |
| N7:100 | 0 | 0 | 0 | 0 | 0 | 0 | 0 | 0 | 0 | 0 |

Symbol: N7:0 Radix: Hex/BCD Columns: 10 Desc: CIP Message Request

Buttons: Properties, Usage, Help

Detail:

N7:0 = 0x8000:Control word with bit EN set

N7:1 = 0x08:Target MAC ID - Node 8

N7:2 = 0x200:Timeout 512 ms

N7:3 = 0x0:Complex IOI size - Not used

N7:4 = 0x19:Set Member service code

N7:5 = 0x04:Target Class code - Identity object class

N7:6 = 0x07:Target Instance number - Instance 7: M0 File

N7:7 = 0x03:Target Attribute number - Data

N7:8 = 0x2BD:Target Member number - 701, one based offset, M0 File Local Database word 700

N7:9 = 0x41:Command Data size - 65 = 1 data length word + 64 words of actual data, copy to M0:1.1100

N7:10 to N7:75:Data copied to M0:1.1100

IMPORTANT

The set member service contains the amount of data to be written in N7:10, followed by the actual data values.

The length contained in N7:9 includes the size word of N7:10, plus the number of data words to be sent.

Example: SLC 500 Ladder Program

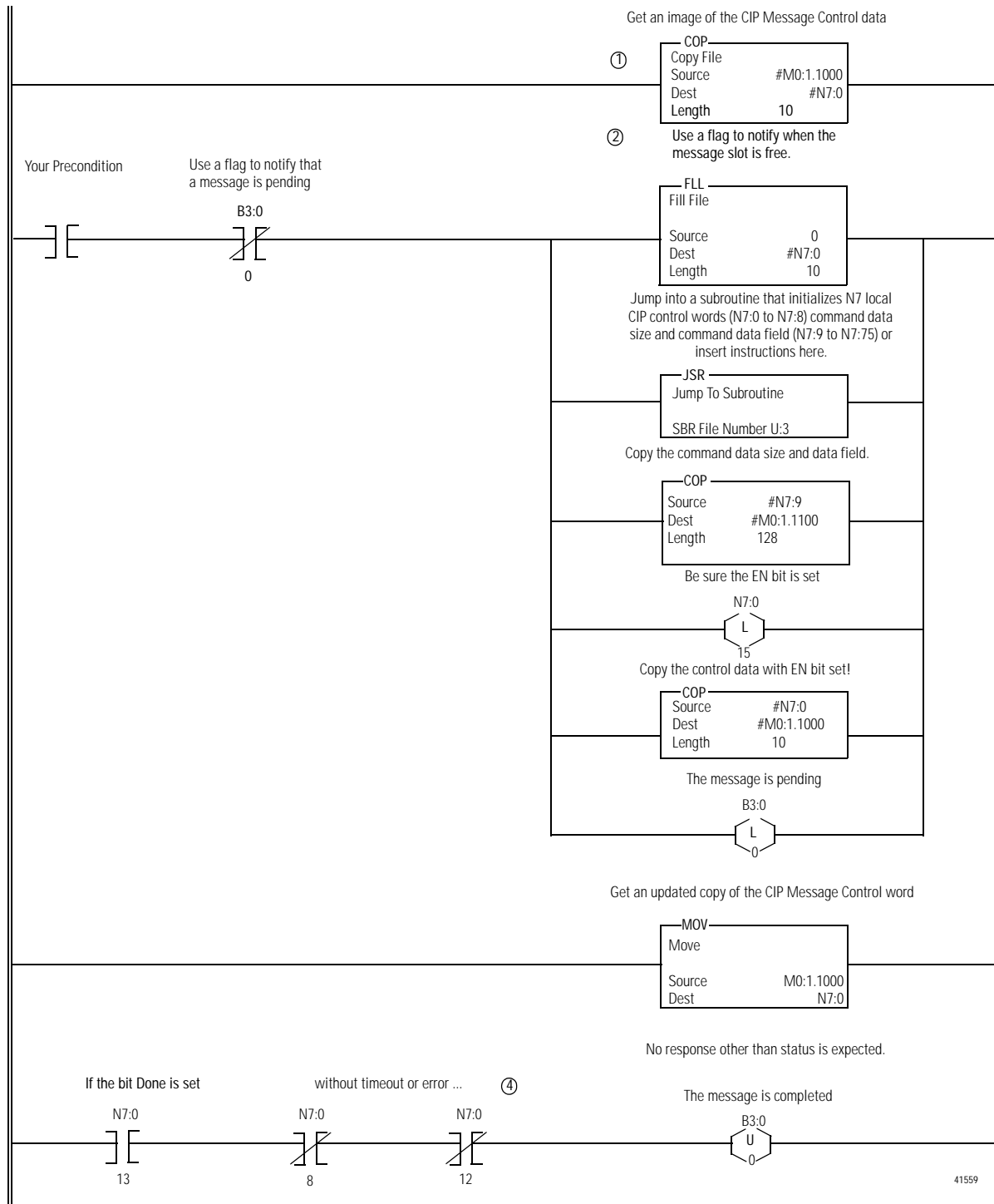

IMPORTANT

When the #M0.e.yyyy address is used in ladder instructions, e is the 1747-SCNR slot number in the SLC rack. If you reuse this example, and your module is not in slot number one, update all instructions with the current appropriate number

SLC 500 Processor: Target Input Data File (hex)

RSLogix 500

The screenshot shows a window titled "Data File N11 (hex)" with a table of hexadecimal data. The table has columns for "Offset" (0-9) and rows for addresses from N11:0 to N11:80. The data is as follows:

| Offset | 0 | 1 | 2 | 3 | 4 | 5 | 6 | 7 | 8 | 9 |
|--------|----|----|----|----|----|----|----|----|----|----|
| N11:0 | 1 | 2 | 3 | 4 | 5 | 6 | 7 | 8 | 9 | A |
| N11:10 | B | C | D | E | F | 10 | 11 | 12 | 13 | 14 |
| N11:20 | 15 | 16 | 17 | 18 | 19 | 1A | 1B | 1C | 1D | 1E |
| N11:30 | 1F | 20 | 21 | 22 | 23 | 24 | 25 | 26 | 27 | 28 |
| N11:40 | 29 | 2A | 2B | 2C | 2D | 2E | 2F | 30 | 31 | 32 |
| N11:50 | 33 | 34 | 35 | 36 | 37 | 38 | 39 | 3A | 3B | 3C |
| N11:60 | 3D | 3E | 3F | 40 | 0 | 0 | 0 | 0 | 0 | 0 |
| N11:70 | 0 | 0 | 0 | 0 | 0 | 0 | 0 | 0 | 0 | 0 |
| N11:80 | 0 | 0 | 0 | 0 | 0 | 0 | 0 | 0 | 0 | 0 |

Below the table, there are fields for "Symbol" (N11:0), "Radix" (Hex/BCD), "Columns" (10), and "Desc". Buttons for "Properties", "Usage", and "Help" are also visible.

N11 file is the image of target node 8 Local Database.

The 1747-SCNR at MAC ID 11 wrote 64 words into the Local Database of 1747-SCNR at MAC ID 8.

Notes:

Example of Reset Bit Management

What This Appendix Contains

This appendix contains an example of how you can use the ladder program to reset a 1747-SCNR module located in the SLC 500 rack.

What We Assume

We assume that you are familiar with ladder programming. Reset bit management is illustrated in the following example. The steps in the procedure correspond to the steps in the illustration following.

Example

Reset bit management is illustrated in the following example. The steps in the procedure correspond to the steps in the illustration.

1. In this example, we reset the scanner when it is faulted.

When the 1747-SCNR sets its fault bit, the scanner slot (slot 3) is disabled and the Output Command word Reset bit is set (O:3.0/8).

2. When the slot is disabled, a timer is started and four seconds later the scanner is enabled.

During these four seconds, you must avoid any access to the scanner in reset. This is why the rung with the TND instruction must be executed first.

IMPORTANT

If you do not disable the slot while the scanner is resetting, the SLC module faults with the error code nn57h (speciality, I/O Module in slot nn has not responded to a lock shared memory command in the requested time limit) where nn is the slot number of the scanner. This is why the reset bit change is not taken into account until the slot is disabled.

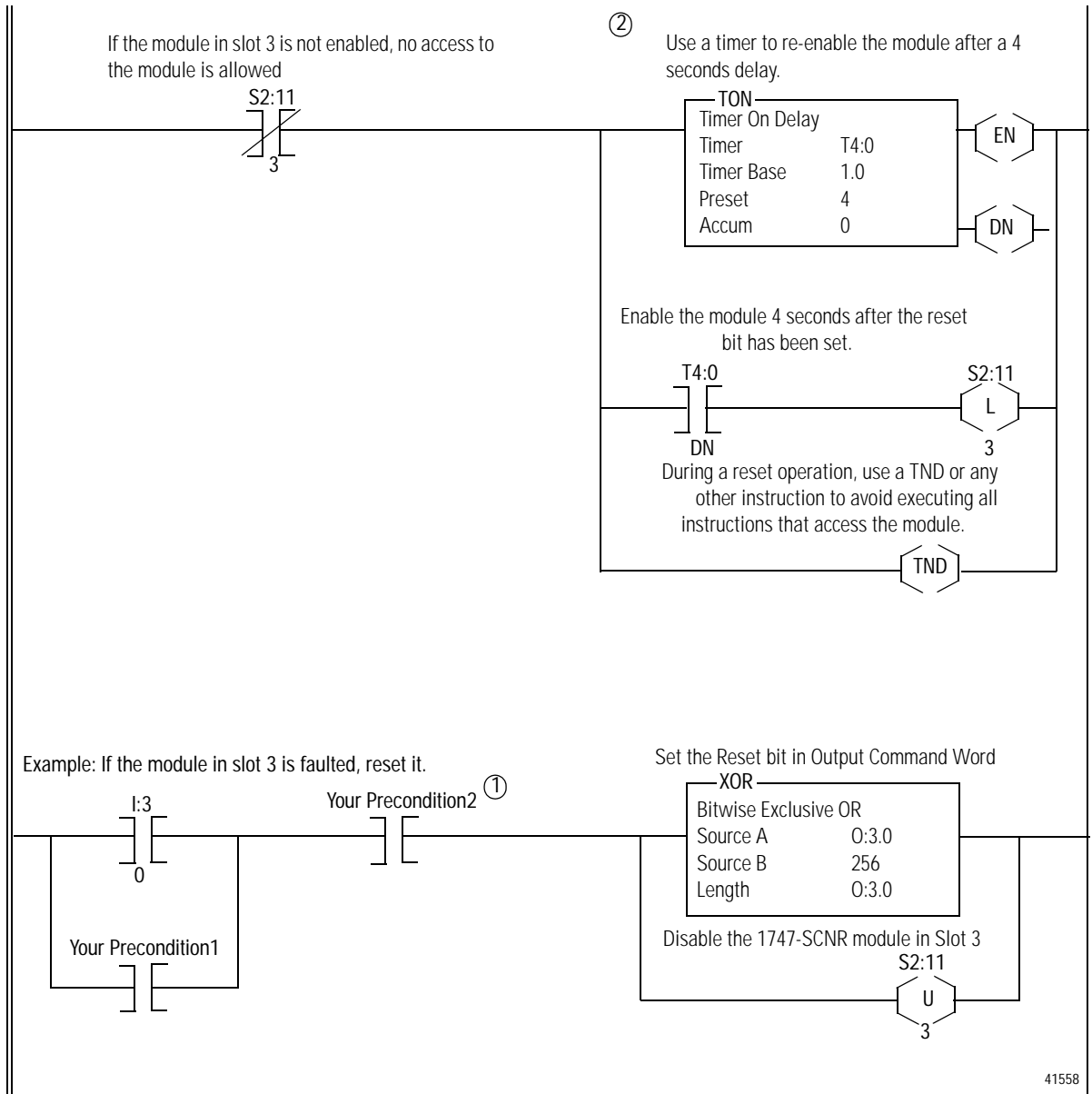

IMPORTANT

In this ladder example, when S2:11\e, I:e\0 or O:e.0 are used, e is the 1747-SCNR slot number in the SLC rack. If you reuse this example and your module is not in slot 3, update all instructions with the current appropriate number.

Application Examples

What This Appendix Contains

This appendix provides examples of applications and their use with the 1747-SCNR scanner controlling discrete and analog data on a ControlNet network via a 1747-ACNR15 and 1794-ACNR15 ControlNet adapter. Also included in this appendix is an example of how to create peer-to-peer scheduled connections between 1747-SCNR ControlNet scanners.

What We Assume

We assume that you are familiar with setting up a network and working with RSLogix500, RSLinx, and RSNetWorx for ControlNet software and the 1784-KTCX15 interface card.

Example 1: Configure the 1747-SCNR Scanner with the 1746-IV16 Input Module

The following example discusses how to configure the 1747-SCNR scanner with the 1746-IV16 input module.

Hardware Setup

The hardware setup for this examples includes a computer with RSLogix500, RSLinx, RSNetWorx for ControlNet software, and a 1784-KTCX15 interface card. The chassis configuration includes a 1747-ACNR15 module in slot 0, 1746-IA16 module in slot 1, 1746-OB16 module in slot 2, and 1746-IV16 module in slot 3.

Configure the ControlNet Network with RSNetWorx for ControlNet Software

Follow this procedure to configure the ControlNet network using RSNetWorx for ControlNet software.

1. Start RSNetWorx for ControlNet software by double clicking its icon.

You see this screen:

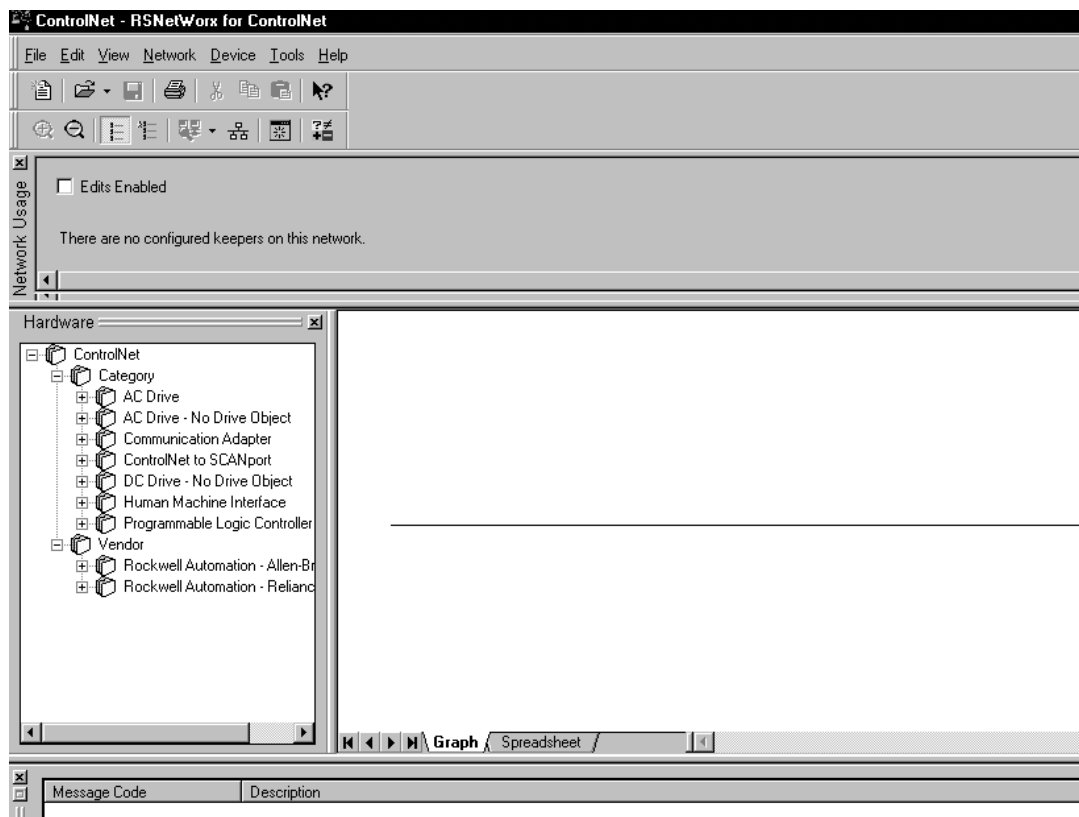

At this time, you can configure your ControlNet network offline and then download it to the network. But in this example, we go online and configure the network.

2. Go online by clicking the Online icon or by clicking the Network menu and selecting Online.

You see the Browse for Network window. In this window, you must select the communication path previously configured in RSLinx software for communicating with your ControlNet network. For this example, a 1784-KTCX15 ControlNet PC card is used.

3. Click the 1784-KTCX15 card to select it.
4. Click OK.

The software attempts to communicate with all possible node numbers on the network, from 1 to 99. The online network screen appears. For this example, the screen should show node 99 as the programming terminal.

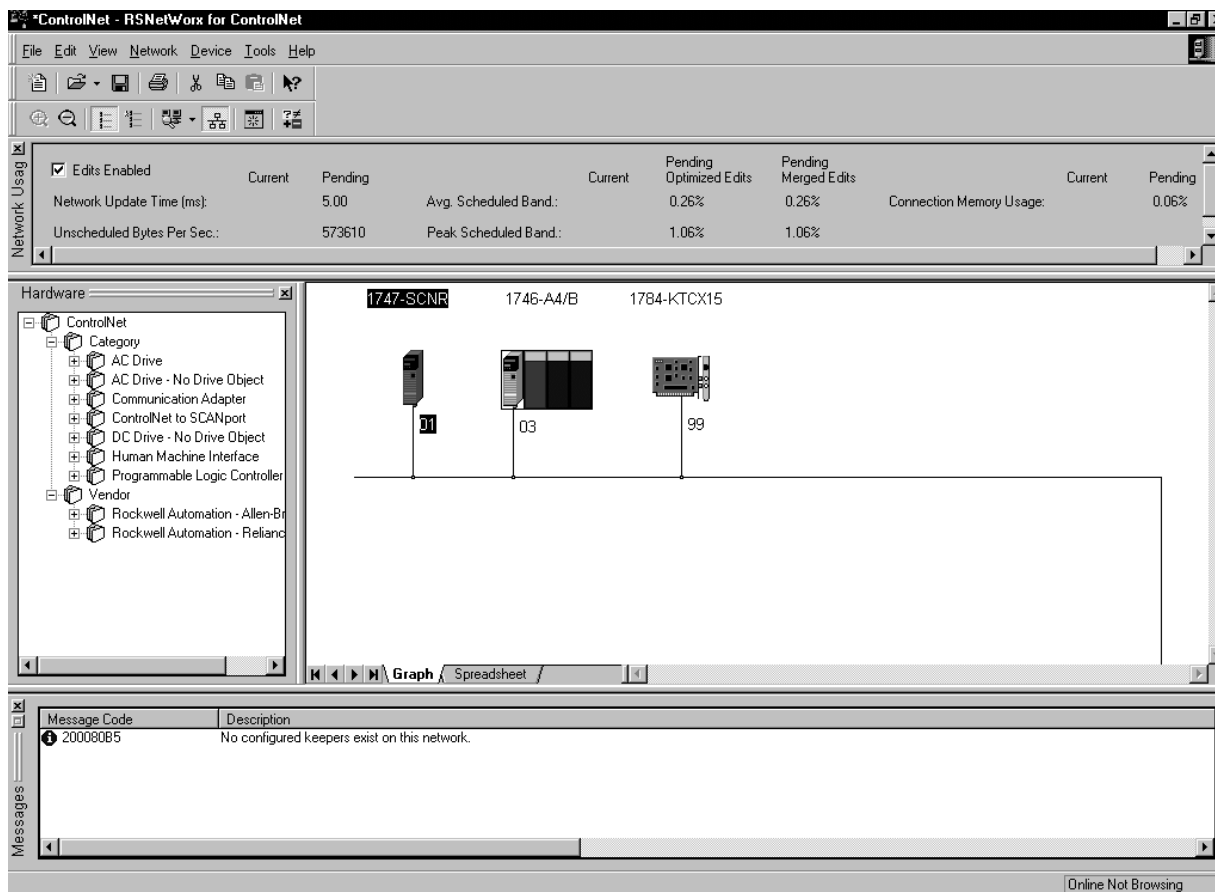

Node 1 is the 1747-SCNR scanner and node 3 is the 1747-ACNR15 module. The 1747-ACNR15 module resides in slot 0 of its chassis, while slot 1 contains a 1746-IA16 module, slot 2 contains a 1746-OB16 module, and slot 3 contains a 1746-IV16 module. For this example, a single 16-bit rack connection is configured to read/write the three discrete I/O modules. Before we create this connection, we should verify the chassis configuration for the 1747-ACNR15 module. To do this:

5. Right-click the 1747-ACNR15 module.
6. Choose Edit Chassis and verify that the chassis configuration is as follows:
 - Slot 0: 1747-ACNR15
 - Slot 1: 1746-IA16
 - Slot 2: 1746-OB16
 - Slot 3: 1746-IV16

If the chassis is not already configured, manually configure it by dragging the appropriate modules from the list on the right to the proper slot on the left of the chassis configuration screen. When this is complete, click APPLY and then OK.

Configure a Rack Connection

We are now ready to configure the necessary ControlNet connection so we can read/write data from the SLC processor to the remote discrete I/O modules.

1. Click-right the 1747-SCNR scanner and choose Scanlist Configuration.

You see a prompt to enter the Edit mode.

2. Click YES to see the following screen:

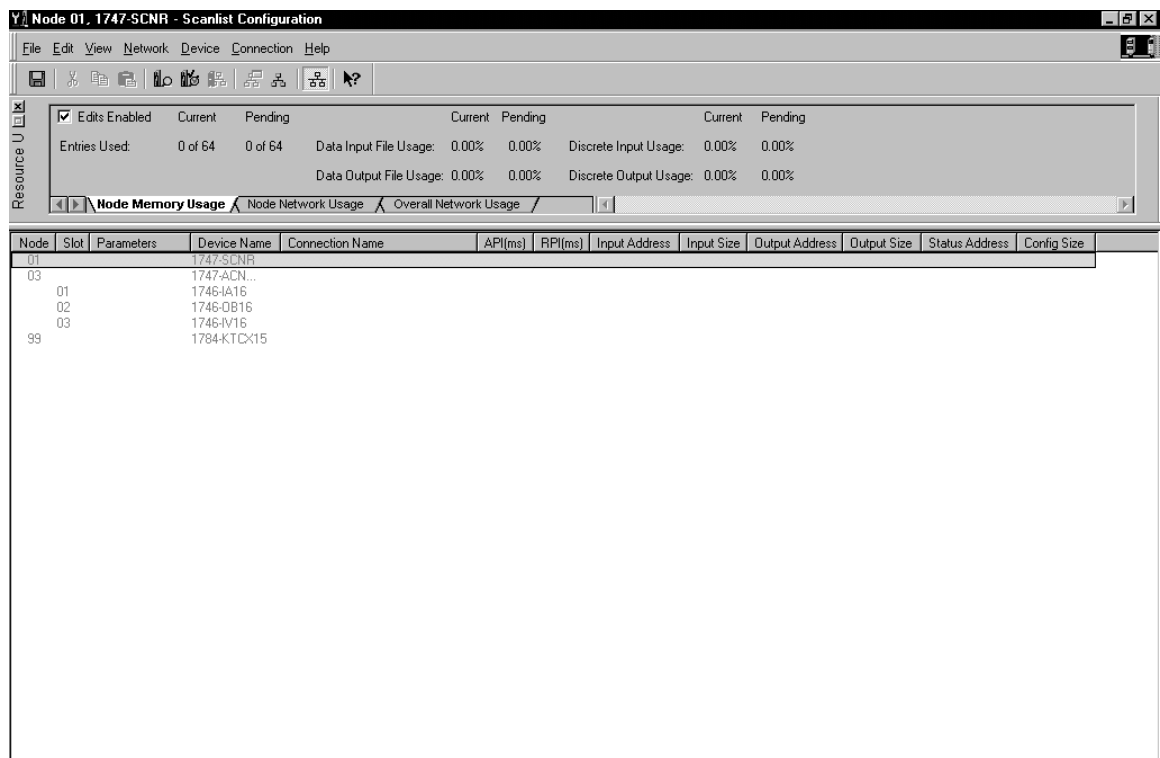

The 1747-SCNR scanner and 1747-ACNR15 module are shown as nodes 1 and 3, respectively.

The three I/O modules are under the 1747-ACNR15 module in slots 1 through 3 of the 1747-ACNR15 chassis.

3. To establish a 16-bit rack connection to the 1747-ACNR15 chassis, click-right the 1747-ACNR15 module and choose Insert Connection.

You see the following window.

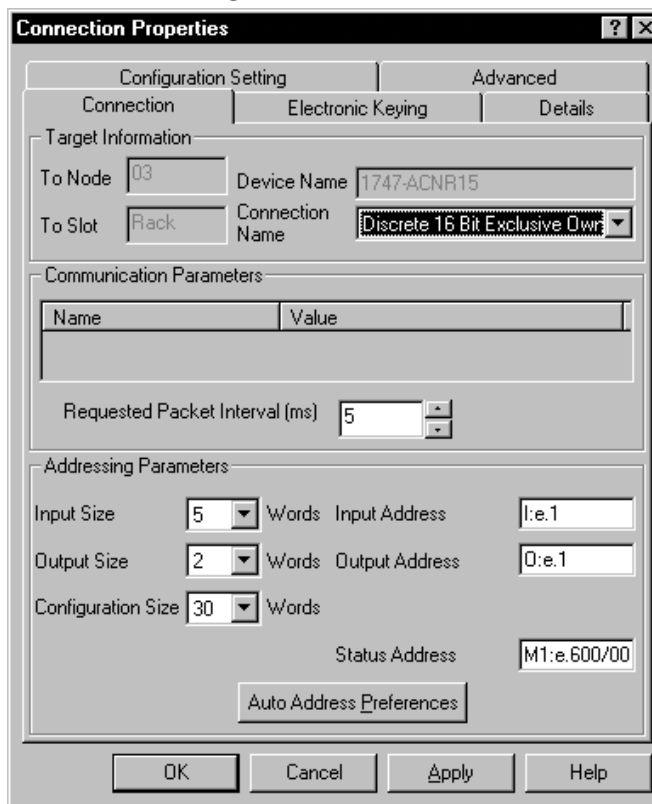

Note that addresses in the Connection Properties window are already displayed in the fields. To have RSNetWorx for ControlNet software, choose the next available valid I/O or M-file addresses for all connections:

- a. Click Auto Address Preferences.
- b. Click the box next to Enable Automatic Addressing on Insert so that a check mark appears in the box.
- c. Click OK.

The Connection Name by default is Discrete 16 Bit Exclusive Owner. This is the 16-bit rack connection we want. The first available I/O addresses are I:3.1 and O:3.1, where the 1747-SCNR scanner is in slot 3 of the processor chassis. The first available starting I/O addresses were placed into the Input Address and Output Address fields, because automatic addressing was previously selected in the Auto Address Preference screen.

Words I:3.0 and O:3.0 are reserved. Note that the input data from the 1746-IA16 module is found in the processor's input image word I:3.3, the output data written to the 1746-OB16 module is from the processor's output image word O:3.2, and the input data from the 1746-IV16 module is in the processor's input image word I:3.5.

IMPORTANT

There is a two-word offset for input data for rack connections. Therefore, for this example, the input data for the input module in slot 1 of the remote 1747-ACNR15 chassis is written to I:3.3 in the SLC processor's input image and the input module in slot 3 is written to I:3.5.

The starting input address configured in RSNetWorx for ControlNet software for this rack connection was I:3.1, but I:3.1 and I:3.2 are used for status information. The Input Size of 5 is shown in the Connection Properties screen.

The actual input data begins after the two words of status information. I:3.4 is not used in this example because an output module resides in slot 2. Also, note that there is no offset for the outputs in a rack connection. O:3.2 is the output image word written to the output module located in slot 2 of the 1747-ACNR15 chassis. O:3.1 is also not used in this example because an input card is in slot 1.

You must also enter a value in the Status Address field. This field supplies Connection Status information to the processor. The starting bit address for this field must be an even number, because two consecutive bits are used as status for each connection. The even numbered bit indicates whether the connection is open or closed and the odd numbered bit indicates whether the connection is in normal operation or Idle mode. In this example, the address chosen is the first available bit pair, M1:3.600/00.

You have successfully configured a rack connection to the remote chassis to communicate with the discrete I/O modules. At this point, you may also configure the state of the outputs in the remote ControlNet Chassis when the processor is placed into the Program mode or if communications is lost to the remote chassis. This is optional. The default is to turn all outputs off when one of the two conditions occur. To select other options follow these steps.

- a. Click the Advanced tab in the Connection Properties window.

You see the following window.

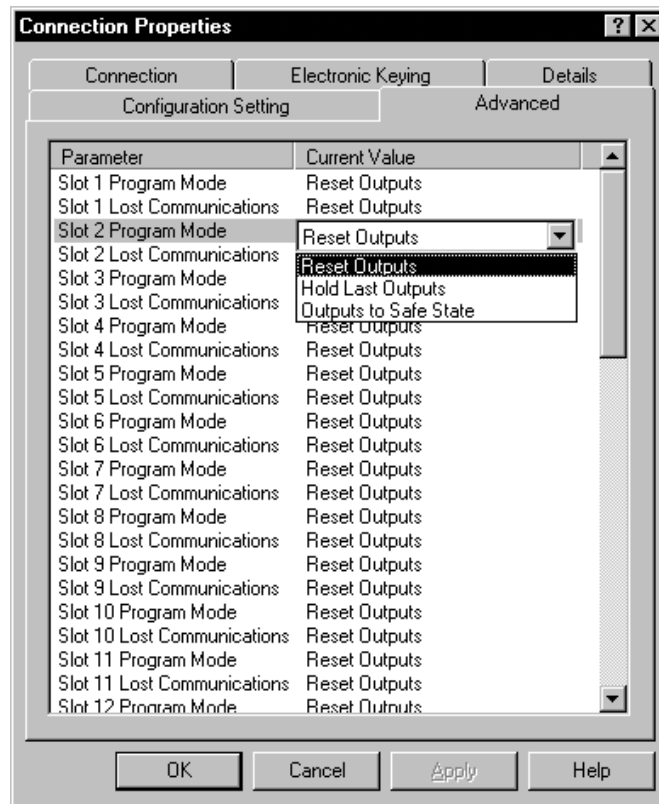

By default for rack connections, outputs in all slots in the remote chassis are reset if the processor is placed into the Program mode or if communications is lost for any reason. Two other choices are offered:

- Hold Last State - all outputs remain in their last state if one of the two conditions occur
- Safe State - lets you to choose exactly the state of each output

If Safe State is selected, you must click the Configuration Settings tab and enter your Safe State data for each output word in decimal. Then, whenever the SLC processor is placed into the Program mode or if communications is lost to the 1747-ACNR15 adapter, the outputs revert to the Safe State data you entered for each output word.

- Click APPLY.
- Click OK.

The Connection Properties window closes and the Scanlist Configuration window should look like the following:

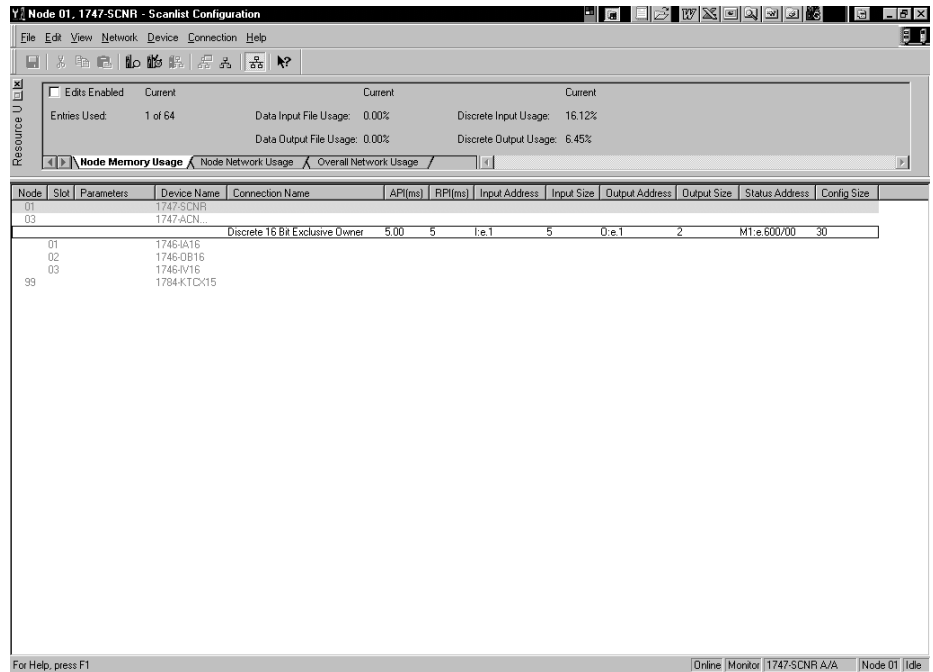

You have now successfully configured a rack connection to read/write data between the SLC processor and the remote ControlNet chassis. All that remains is to save the configuration to the network keeper, which in this case is the 1747-SCNR scanner.

1. Click the Save icon or click the File menu and then Save.

You are prompted to Optimize and re-write schedule for all connections.

2. Click OK.

3. Click YES.

Your network configuration information is now written to the network keeper.

The display on the front of your 1747-SCNR scanner should show an image of a full glass next to the word I/O. This indicates that all configured connections have been successfully downloaded to the scanner. In addition, the A and OK LEDs should be solid green and the B LED should be off, unless you are using the redundant media option, which is not being used in this example. The 1747-ACNR15 module should be displaying that it is active (ACTV) and its LEDs should be solid green for A and OK and the B LED should be off.

Creating a Ladder Program

The final step is to write a ladder program for the SLC processor, including configuring the 1747-SCNR scanner for slot 3 of the processor's chassis.

1. After downloading the program to your processor, place it into the Run mode.
2. Set the Run/Idle bit (O:e.0/10, where e=slot number of your 1747-SCNR scanner) to a 1.

Your program should now be able to read data from the 1746-IA16 in word I:3.3, write to the 1746-OB16 in word O:3.2 and read data from the 1746-IV16 in word I:3.5.

Example 2: Configure the 1747-SCNR Scanner with the 1746-NIO4V Analog Input/Output Module

The following example discusses how to configure the 1747-SCNR scanner with the 1746-NIO4V combination analog input/output module.

Hardware Setup

The hardware setup for this examples includes a computer with RSLogix500, RSLinx, RSNetWorx for ControlNet software, and a 1784-KTCX15 interface card. The chassis configuration includes a 1747-ACNR15 module in slot 0, 1746-IA16 module in slot 1, 1746-OB16 module in slot 2, and 1746-NIO4V module in slot 3.

Configure the ControlNet Network with RSNetWorx for ControlNet Software

Follow the procedure below to configure the ControlNet network using RSNetWorx for ControlNet software.

1. Start RSNetWorx for ControlNet software by double-clicking its icon.

You see this screen:

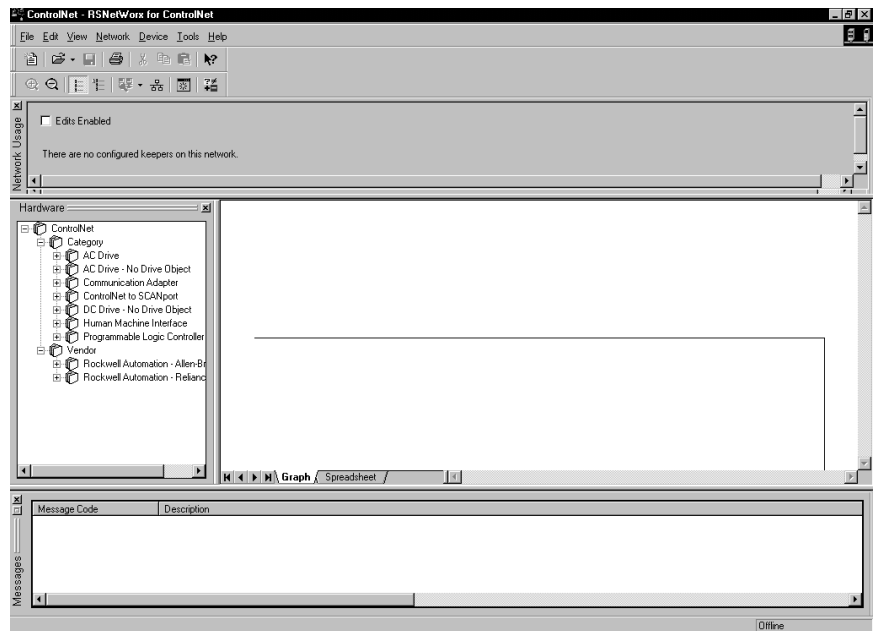

At this time, you can configure your ControlNet network offline and then download it to the network. But in this example, we go online and configure the network.

2. Go online by clicking the Online icon or by clicking the Network menu and selecting Online.

You see the Browse for Network window. In this window, you must select the communication path previously configured in RSLinx software for communicating with your ControlNet network. For this example, a 1784-KTCX15 ControlNet PC card is used.

3. Click the 1784-KTCX15 card to select it.
4. Click OK.

The software attempts to communicate with all possible node numbers on the network, from 1 to 99. The online network screen appears. For this example, the screen should show node 99 as the programming terminal as shown below.

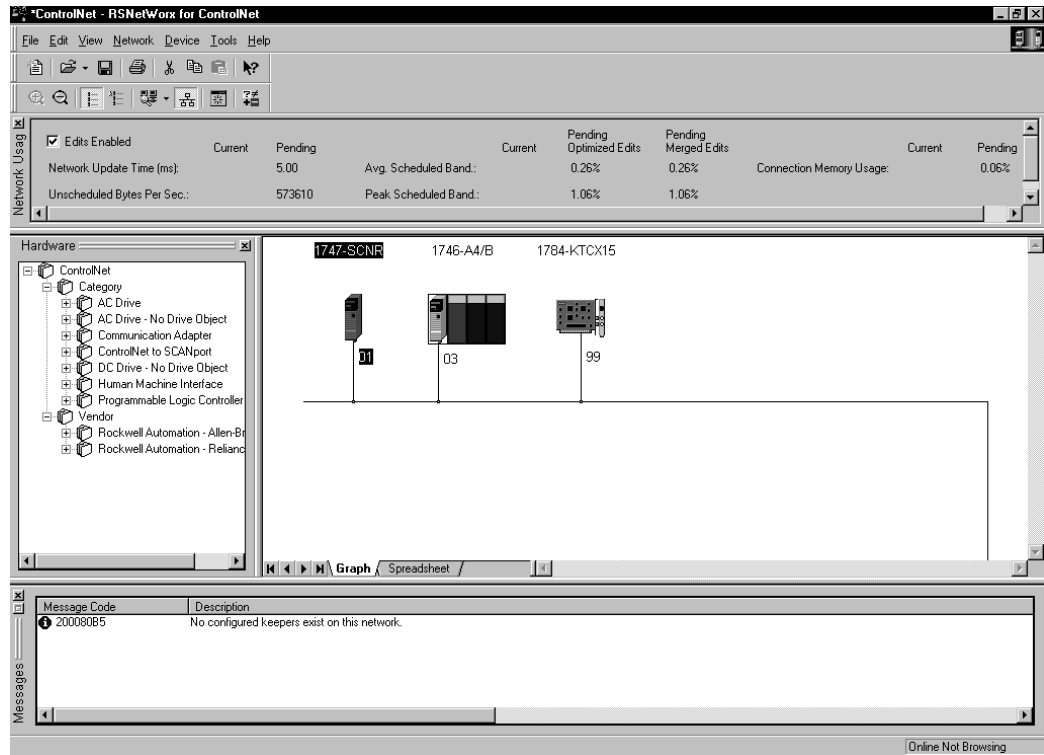

Node 1 is the 1747-SCNR scanner and node 3 is the 1747-ACNR15 module. The 1747-ACNR15 module resides in slot 0 of its chassis, while slot 1 contains a 1746-IA16 module, slot 2 contains a 1746-OB16 module, and slot 3 contains a 1746-NIO4V module. For this example, two separate ControlNet connections are configured. The first is a Discrete 16-Bit Exclusive-Owner rack connection for the two discrete I/O modules. The second will be a Module Connection to the 1746-NIO4V 2 input/2 output analog module. Before we create this connection, we should verify the chassis configuration for the 1747-ACNR15 module. To do this:

5. Right-click the 1747-ACNR15 module.
6. Choose Edit Chassis and verify that the chassis configuration is as follows:
 - slot 0: 1747-ACNR15
 - slot 1: 1746-IA16
 - slot 2: 1746-OB16
 - slot 3: 1746-NIO4V

If the chassis is not already configured, manually configure it by dragging the appropriate modules from the list on the right to the proper slot on the left of the chassis configuration screen. When this is complete, click APPLY and then OK.

Configure a Rack Connection

We are now ready to configure the necessary ControlNet connection so we can read/write data from the SLC processor to the discrete I/O modules and to the analog I/O module.

1. Right-click the 1747-SCNR scanner and choose Scanlist Configuration.

You are prompted to enter the Edit mode.

2. Click YES.

You see the following screen:

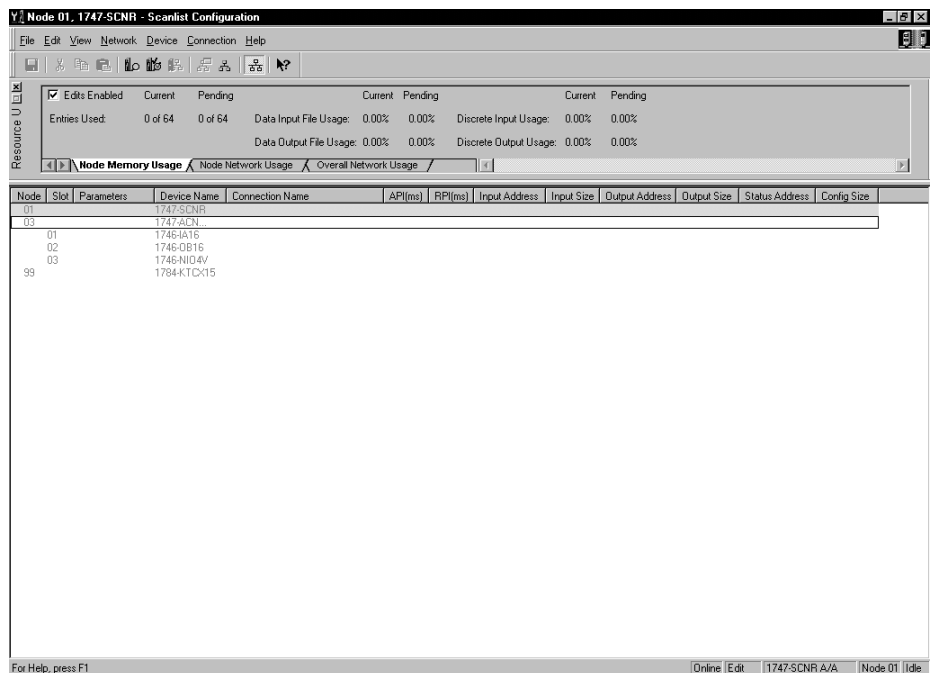

The 1747-SCNR and 1747-ACNR15 modules are shown as nodes 1 and 3, respectively. The three I/O modules are under the 1747-ACNR15 module in slots 1 through 3 of the 1747-ACNR15 chassis.

3. To establish a 16-bit rack connection to the 1747-ACNR15 chassis, right-click the 1747-ACNR15 module and choose Insert Connection.

You see the following window.

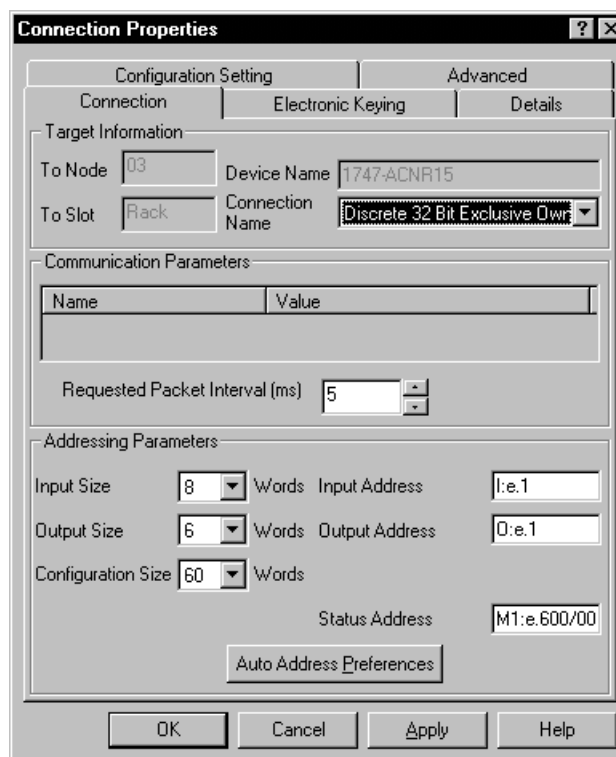

Note that addresses in the Connection Properties window are already displayed in the fields. To have RSNetWorx for ControlNet software choose the next available, valid I/O or M-file addresses for all connections:

- Click the Auto Address Preferences button.
- Click the box next to Enable Automatic Addressing on Insert so that a check mark appears in the box.
- Click OK.

The Connection Name by default is Discrete 16 Bit Exclusive Owner. This is the 16-bit rack connection we want. The first available I/O addresses are I:3.1 and O:3.1, where the 1747-SCNR scanner is in slot 3 of the processor chassis. The first available starting I/O addresses have been placed into the Input Address and Output Address fields, because automatic addressing was previously selected in the Auto Address Preference screen.

Words I:3.0 and O:3.0 are reserved. Note that the input data from the 1746-IA16 is found in the processor's input image word I:3.3, the output data written to the 1746-OB16 module will be from the processor's output image word O:3.2.

IMPORTANT

There is a two-word offset for input data for rack connections. Therefore, for this example, the input data for the input module in slot 1 of the remote 1747-ACNR15 chassis will be written to I:3.3 in the SLC processor's input image.

The starting input address configured in RSNetWorx for ControlNet software for this rack connection was I:3.1, but I:3.1 and I:3.2 are used for status information. Therefore, the actual input data begins after the two words of status information. I:3.4 is not used in this example because an output module resides in slot 2.

Also, note that there is no offset for the outputs in a rack connection. O:3.2 is the output image word written to the output module located in slot 2 or the 1747-ACNR15 chassis. In addition, no offset applies to module connections at all. For this example, the input and output data for the 1746-NIO4V module is located in M1:3.3, M1:3.4, M0:3.3, and MO:3.4. M1:3.3 and MO:3.3 are the starting addresses entered in RSNetWorx for ControlNet software for the module connection.

You must also enter a value in the Status Address field. This field supplies Connection Status information to the processor for each unique connection. The bit address for this field must be an even number, because two consecutive bits are used as status for each connection. The even numbered bit indicates whether the connection is open or closed and the odd numbered bit indicates whether the connection is in normal operation or Idle mode. In this example, the starting address chosen is the first available bit, M1:3.600/00.

You have successfully configured a rack connection to the remote chassis to communicate with the two discrete I/O modules. At this point, you may also configure the state of the outputs in the remote ControlNet Chassis when the processor is placed into the Program Mode or if communications is lost to the remote chassis. This is optional. The default is to turn all outputs off when one of the two conditions occur. To select other options:

- a. Click the Advanced tab in the Connection Properties window.

You see the following window.

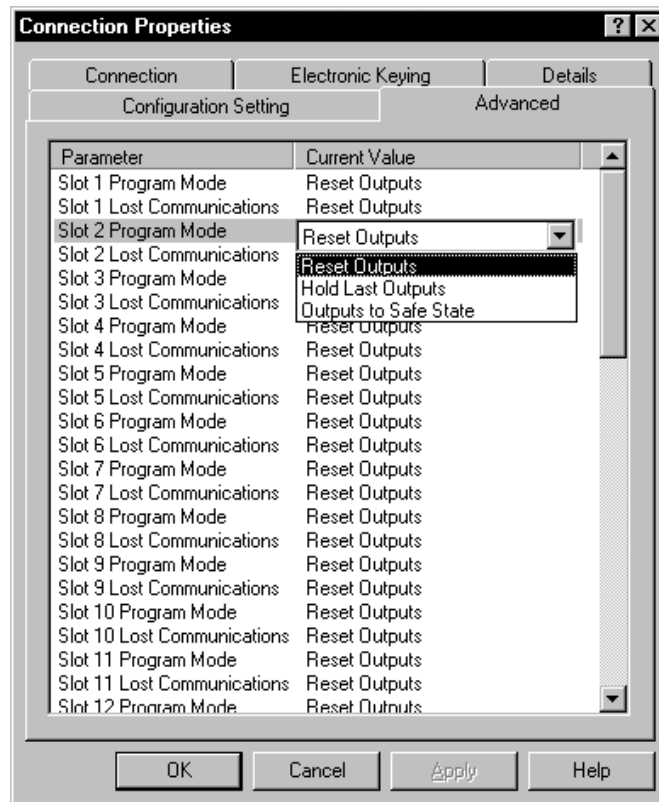

By default, outputs in all slots in the remote chassis are reset if the processor is placed into the Program mode or if communications is lost for any reason. Two other choices are offered:

- Hold Last State - all outputs remain in their last state if one of the two conditions occur
- Safe State - lets you to choose the state of each output

If Safe State is selected, you must click the Configuration Settings tab and enter your Safe State data for each output word in decimal. Then, whenever the SLC processor is placed into the Program Mode or if communications is lost to the 1747-ACNR15 adapter, the outputs revert to the Safe State data you entered for each output word.

- Click APPLY.
- Click OK to return to the Scanlist Configuration screen.

Configure a Module Connection

Next, we need to configure a module connection for the 1746-NIO4V module, 2 input/2 output module.

1. Right-click the 1746-NIO4V module in the Scanlist Configuration window.
2. Select Insert Connection.

A Connection Properties window appears.

3. Choose Exclusive Owner for the connection name.

For this example, we must choose M-file addresses for our 2 input/2 output analog module. The first available M-file addresses are M1:3.3 and M0:3.3. Words 0 through 2 are reserved. The next available Status Address is M1:3.600/02, since bits 0 and 1 are used for the rack connection. The Connection Properties window for the module connection should look like the following:

Connection Properties

| Configuration Setting | | Advanced | |
|---------------------------------|-------|-------------------|-----------------|
| Connection | | Electronic Keying | Details |
| Target Information | | | |
| To Node | 03 | Device Name | 1746-NIO4V |
| To Slot | 03 | Connection Name | Exclusive Owner |
| Communication Parameters | | | |
| Name | Value | | |
| Requested Packet Interval (ms) | | | |
| 20 | | | |
| Addressing Parameters | | | |
| Input Size | 2 | Words | Input Address |
| | | | M1:e.3 |
| Output Size | 2 | Words | Output Address |
| | | | M0:e.3 |
| Configuration Size | 4 | Words | |
| | | | Status Address |
| | | | M1:e.600/02 |
| Auto Address Preferences | | | |

OK Cancel Apply Help

At this point, the state of the two analog outputs should be determined and set in the Advanced and Configuration Settings tabs in the Connection Properties window for this module connection, provided you do not want the default settings of 0 decimal. This is the same as we did for discrete outputs for the rack connection. This merely determines the state of the two analog outputs when the SLC processor is placed in the Program mode or if communications is lost to the 1747-ACNR15 module.

4. Click APPLY.
5. Click OK.

The Connection Properties window closes and the Scanlist Configuration window appears and looks like the following.

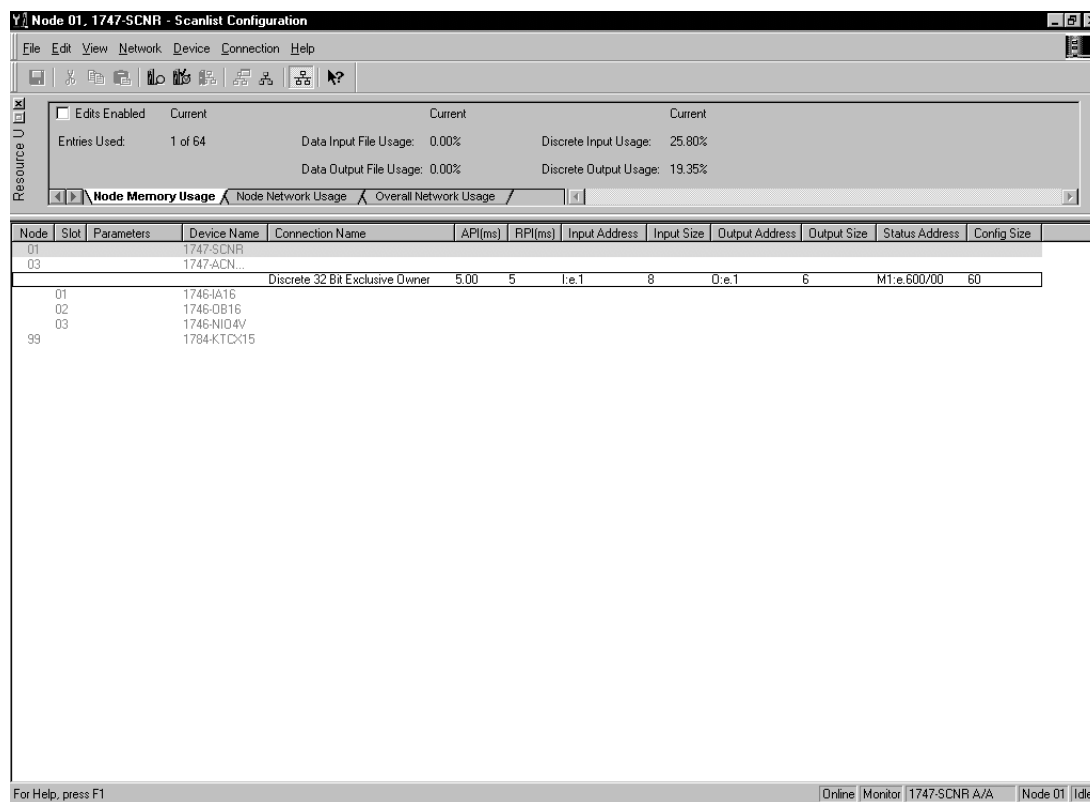

You have successfully configured your two connections to read/write data between the SLC processor and the remote ControlNet chassis. All that remains is to save the configuration to the network keeper, which in this case is the 1747-SCNR scanner.

1. Click the Save icon or click the File menu and choose Save.

You are prompted to Optimize and re-write schedule for all connections.

2. Click OK.
3. Click YES.

Your network configuration information are now written to the network keeper.

The display on the front of your 1747-SCNR scanner should show an image of a full glass next to the word I/O. This indicates that all configured connections have been successfully downloaded to the scanner. In addition, the A and OK LEDs should be solid green and the B LED should be off, unless you are using the redundant media option, which is not being used in this example. The 1747-ACNR15 module should be displaying that it is active (ACTV) and its LEDs should be solid green for A and OK and the B LED should be off.

Creating a Ladder Program

The final step is to write a ladder program for the SLC processor, including configuring the 1747-SCNR scanner for slot 3 of the processor's chassis.

1. After downloading the program to your processor, place it into the Run mode.

Your program should now be able to read data from the 1746-IA16 in word I:3.3 and write to the 1746-OB16 in word O:3.2. The analog input data will reside in words M1:3.3 and M1:3.4, while the analog output data must be placed in words M0:3.3 and M0:3.4.

Note that your ladder program should also contain an unconditional rung with an OTE instruction addressed to the 1747-SCNR scanner's Run/Idle bit, O:3.0/10 for this example. When the SLC processor is placed into the Run mode, this rung will set the 1747-SCNR scanner's Run/Idle bit and place the scanner into the Run mode as well. The scanner will begin executing the configured connections when the Run/Idle bit is set.

Example 3: Configure the 1747-SCNR Scanner with the 1746-NI8 Analog Input Module

The following example discusses how to configure the 1747-SCNR scanner with the 1746-NI8 analog input module.

Hardware Setup

The hardware setup for this examples includes a computer with RSLogix500, RSLinx, RSNetWorx for ControlNet software, and a 1784-KTCX15 interface card. The chassis configuration includes a 1747-ACNR15 module in slot 0, 1746-IA16 module in slot 1, 1746-OB16 module in slot 2, and 1746-NI8 module in slot 3.

Configure the ControlNet Network with RSNetWorx for ControlNet Software

Follow the procedure below to configure the ControlNet network using RSNetWorx for ControlNet software.

1. Start RSNetWorx for ControlNet software by double clicking its icon.

You see this screen:

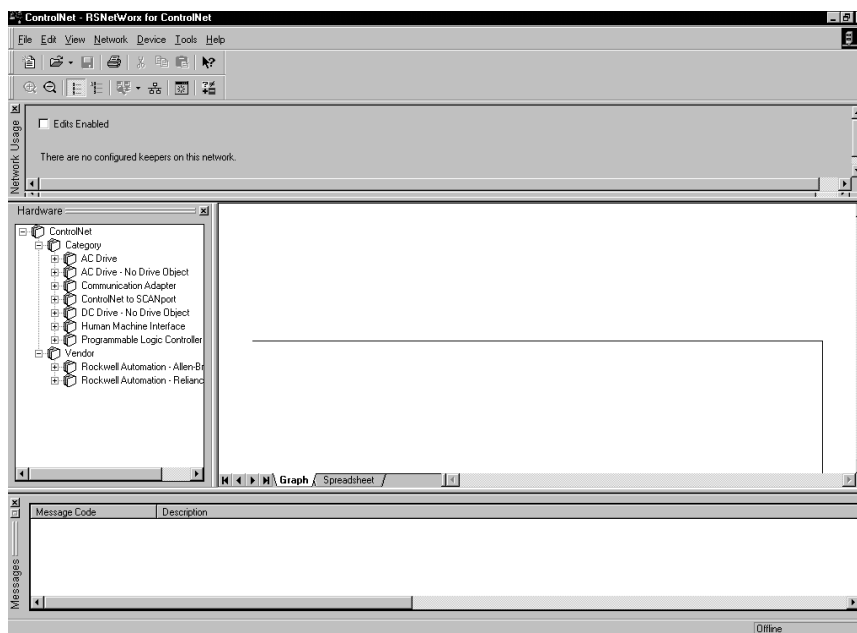

At this time, you can configure your ControlNet network offline and then download it to the network. But in this example, we will go online and configure the network.

2. Go online by clicking the Online icon or by clicking the Network menu and selecting Online.

You see the Browse for Network window.

In this window, you must select the communication path previously configured in RSLinx software for communicating with your ControlNet network. For this example, a 1784-KTCX15 ControlNet PC card is used.

3. Click the 1784-KTCX15 card to select it.
4. Click OK.

The software will attempt to communicate with all possible node numbers on the network, from 1 to 99. The online network screen appears. For this example, the screen should show node 99 as the programming terminal as shown below.

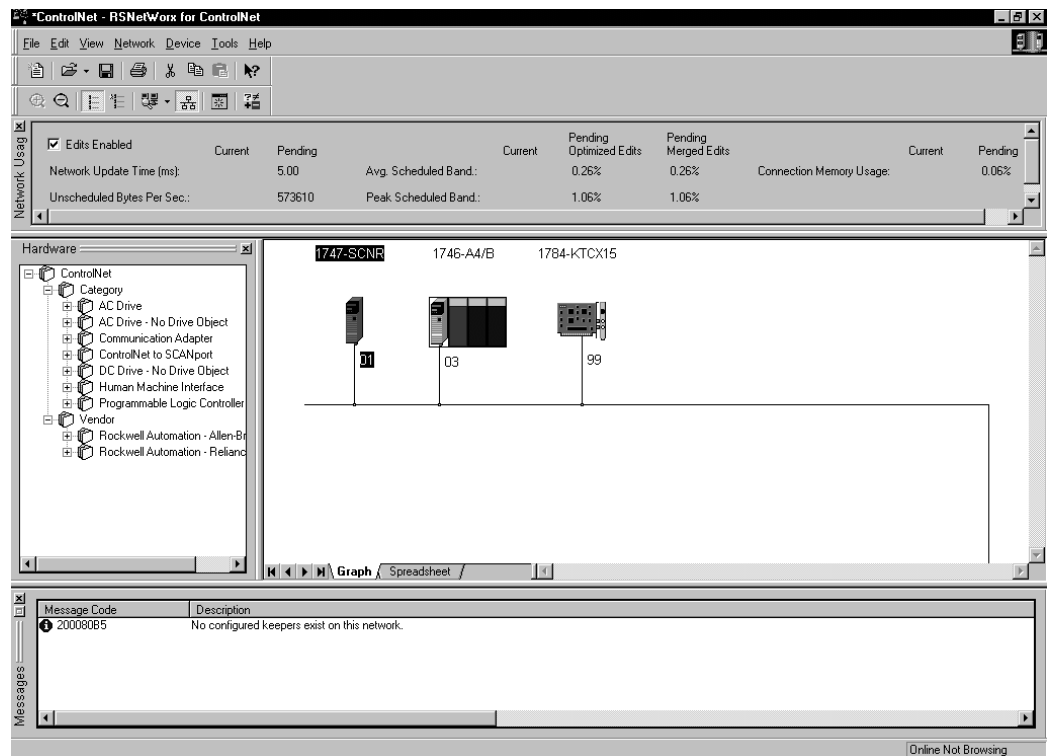

Node 1 is the 1747-SCNR scanner and node 3 is the 1747-ACNR15 module. The 1747-ACNR15 module resides in slot 0 of its chassis, while slot 1 contains a 1746-IA16, slot 2 contains a 1746-OB16, and slot 3 contains a 1746-NI8. For this example, two separate ControlNet connections will be configured. The first will be a Discrete 16 Bit Exclusive Owner rack connection for the two discrete I/O modules. The second will be a Module Connection to the 1746-NI8 8 input analog module. Before we create this connection, we should verify the chassis configuration for the 1747-ACNR15 module. To do this:

5. Right-click the 1747-ACNR15 module.

6. Choose Edit Chassis and verify that the chassis configuration is as follows:

- slot 0: 1747-ACNR15
- slot 1: 1746-IA16
- slot 2: 1746-OB16
- slot 3: 1746-NI8

If the chassis is not already configured, manually configure it by dragging the appropriate modules from the list on the right to the proper slot on the left of the chassis configuration screen. When this is complete, click APPLY and then OK.

Configure a Rack Connection

We are now ready to configure the necessary ControlNet connections so we can read/write data from the SLC processor to the discrete I/O modules and to the analog I/O module.

1. Right-click the 1747-SCNR scanner and choose Scanlist Configuration.

You are prompted to enter the Edit mode.

2. Click YES.

You see the following screen:

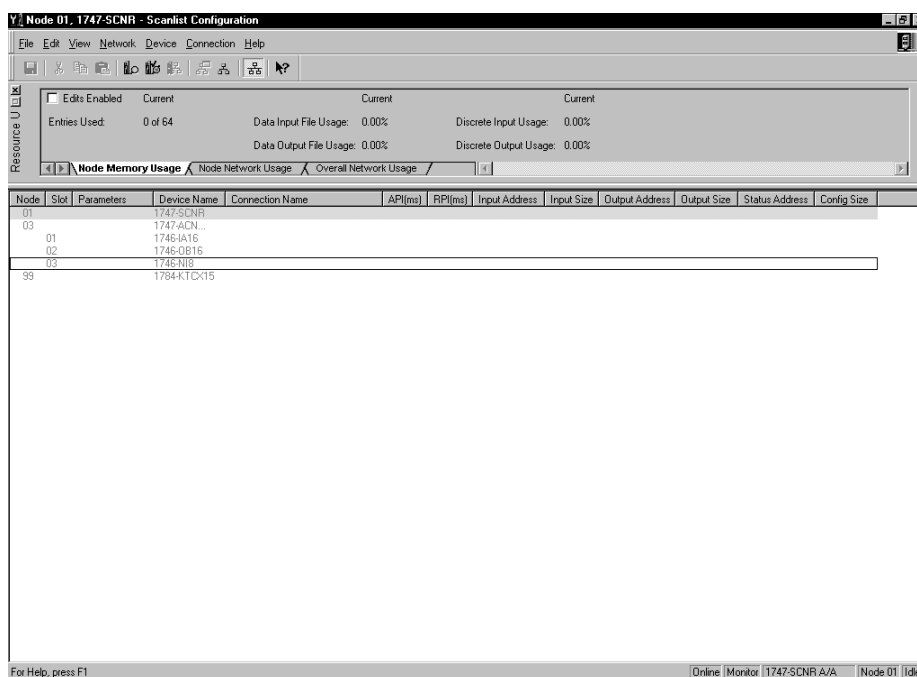

The 1747-SCNR and 1747-ACNR15 modules are shown as nodes 1 and 3, respectively. The three I/O modules are under the 1747-ACNR15 in slots 1 through 3 of the 1747-ACNR15 chassis.

3. To establish a 16-bit rack connection to the 1747-ACNR15 chassis, right-click the 1747-ACNR15 and choose ControlNet Configuration.

You see the following window.

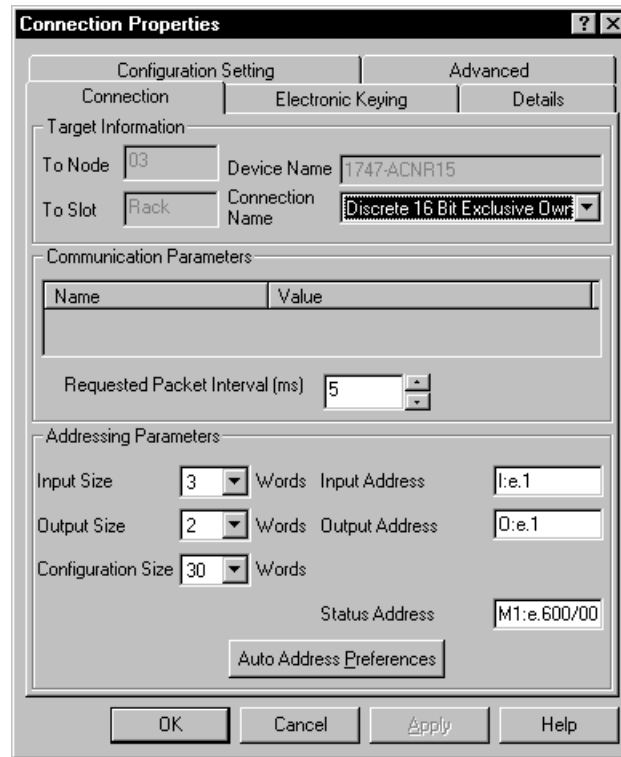

Note that addresses in the Connection Properties window are already displayed in the fields. To have RSNetWorx for ControlNet software choose the next available, valid I/O or M-file addresses for all connections:

- a. Click the Auto Address Preferences button.
- b. Click the box next to Enable Automatic Addressing on Insert so that a check mark appears in the box.
- c. Click OK.

The Connection Name by default is Discrete 16 Bit Exclusive Owner. This is the 16-bit rack connection we want. The first available I/O addresses are I:3.1 and O:3.1, where the 1747-SCNR scanner is in slot 3 of the processor chassis. The first available starting I/O addresses have been placed into the Input Address and Output Address fields, because automatic addressing was previously selected in the Auto Address Preference screen.

Words I:3.0 and O:3.0 are reserved. Note that the input data from the 1746-IA16 module are found in the processor's input image word I:3.3. The output data written to the 1746-OB16 module will be from the processor's output image word O:3.2.

IMPORTANT

There is a two-word offset for input data for rack connections. Therefore, for this example, the input data for the input module in slot 1 of the remote 1747-ACNR15 chassis will be written to I:3.3 in the SLC processor's input image.

The starting input address configured in RSNetWorx for ControlNet software for this rack connection was I:3.1, but I:3.1 and I:3.2 are used for status information. Therefore, the actual input data begins after the two words of status information. I:3.4 and I:3.5 are not used in this example because an output module resides in slot 2 and an analog module resides in slot 3.

Also, note that there is no offset for the outputs in a rack connection. O:3.2 is the output image word written to the output module located in slot 2 of the 1747-ACNR15 chassis. In addition, no offset applies to module connections at all.

You must also enter a value in the Status Address field. This field supplies Connection Status information to the processor for each unique connection. The bit address for this field must be an even number, because two consecutive bits are used as status for each connection. The even numbered bit indicates whether the connection is open or closed and the odd numbered bit indicates whether the connection is in normal operation or Idle mode. In this example, the starting address chosen is the first available bit pair, M1:3.600/00.

You have successfully configured a rack connection to the remote chassis to communicate with the two discrete I/O modules. At this point, you may also configure the state of the outputs in the remote ControlNet Chassis when the processor is placed into the Program Mode or if communications is lost to the remote chassis. This is optional. The default is to turn all outputs off when one of the two conditions occur. To select other options:

1. Click the Advanced tab in the Connection Properties window.

You see the following window:

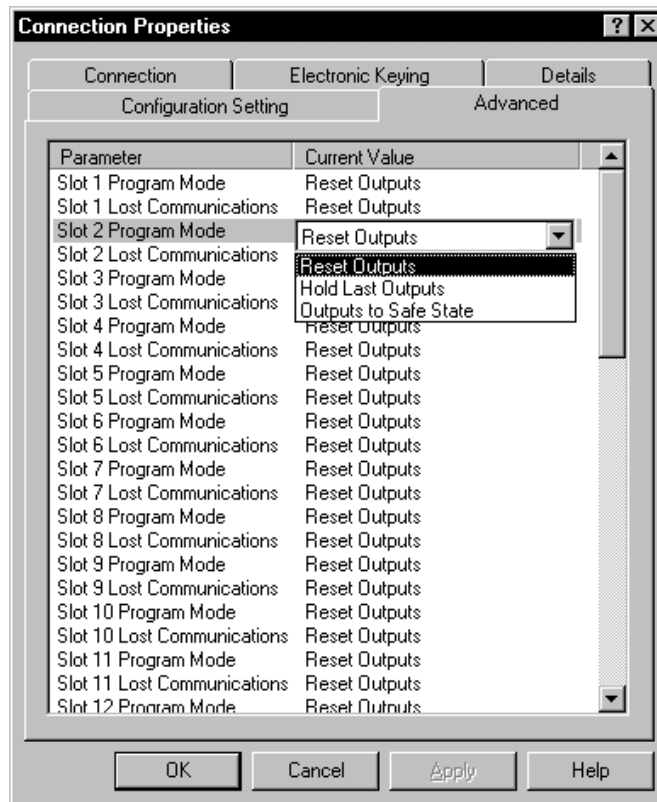

By default, outputs in all slots in the remote chassis are reset if the processor is placed into the Program mode or if communications is lost for any reason. Two other choices are offered:

- Hold Last State - all outputs remain in their last state if one of the two conditions occur
- Safe State - lets you to choose exactly the state of each output

If Safe State is selected, you must click the Configuration Settings tab and enter your Safe State data for each output word in decimal. Then, whenever the SLC processor is placed into the Program Mode or if communications is lost to the 1747-ACNR15 adapter, the outputs revert to the Safe State data you entered for each output word.

2. Click APPLY.
3. Click OK to accept the rack connection.

Configure a Module Connection

Next, we need to configure a module connection for the 1746-NI8 input analog module.

1. Right-click the 1746-NI8 module in the Scanlist Configuration window.
2. Select Insert Connection.

A Connection Properties window appears.

3. Choose Exclusive Owner for the connection name.

For this example, we must choose M-file addresses for our 8 input analog module. The 1746-NI8 module must use Class 3 operation in a 1747-ACNR15 chassis. It requires 12 output words and 16 input words. M-file words will be used for this in the 1747-SCNR scanner. M0:3.3 through M0:3.14 will be used for the 12 output words used to configure the module and M1:3.3 through M1:3.18 are used for the input information, including actual analog data and analog channel status.

Refer to the SLC 500 Analog Input Module User Manual, publication number 1746-6-8 for additional information on this module. M-file words M1:3.0, M1:3.1, M1:3.2, M0:3.0, M0:3.1, and M0:3.2 are reserved. The next available status address is M1:3.600/02, since bits 0 and 1 are used for the rack connection.

The Connection Properties window for the module connection should look as follows:

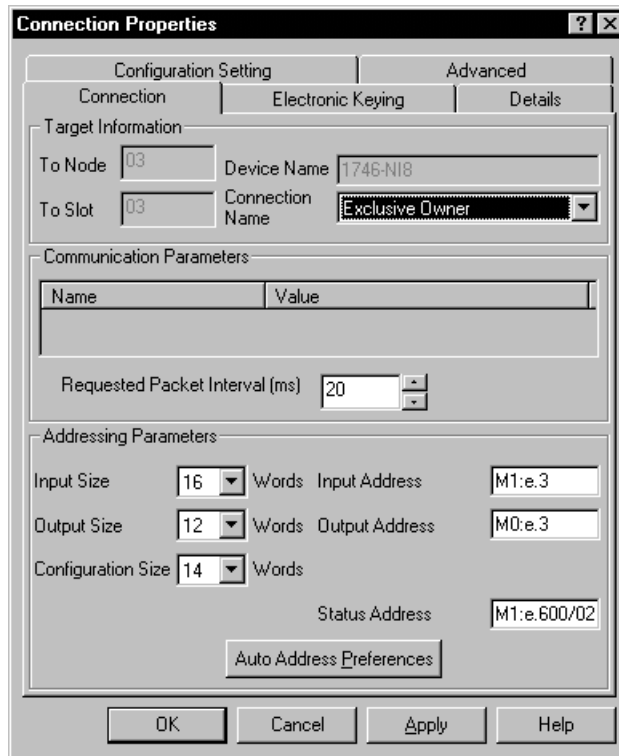

4. Click APPLY.
5. Click OK.

The Connection Properties window closes and the Scanlist Configuration window appears and looks as follows:

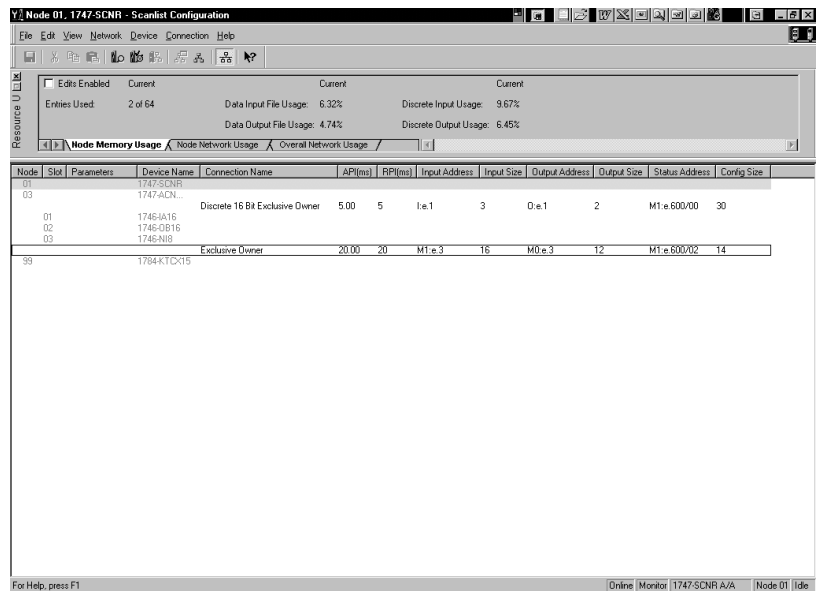

You have successfully configured your two connections to read/write data between the SLC processor and the remote ControlNet chassis. All that remains is to save the configuration to the network keeper, which in this case is the 1747-SCNR scanner.

1. Click the Save icon or choose the File menu and then Save.

You are prompted to Optimize and re-write schedule for all connections.

2. Click OK.
3. Click YES to the warning message.

Your network configuration information is now written to the network keeper.

The display on the front of your 1747-SCNR scanner should show an image of a full glass next to the word I/O. This indicates that all configured connections have been successfully downloaded to the scanner. In addition, the A and OK LEDs are solid green and the B LED are off, unless you are using the redundant media option, which is not being used in this example. The 1747-ACNR15 module is displaying that it is active (ACTV) and its LEDs are solid green for A and OK and the B LED is off.

Creating a Ladder Program

The final step is to write a ladder program for the SLC processor, including configuring the 1747-SCNR scanner for slot 3 of the processor's chassis.

- After downloading the program to your processor, place it into the Run mode.

Your program should now be able to read data from the 1746-IA16 in word I:3.3 and write to the 1746-OB16 in word O:3.2. The analog input data and channel status will reside in words M1:3.3 and M1:3.18, while the analog module configuration data must be placed in words M0:3.3 and M0:3.14.

Note that your ladder program should also contain an unconditional rung with an OTE instruction addressed to the 1747-SCNR scanner's Run/Idle bit, O:3.0/10 for this example.

When the SLC processor is placed into the Run mode, this rung will set the 1747-SCNR scanner's Run/Idle bit and place the scanner into the Run mode as well. The scanner will begin executing the configured connections when the Run/Idle bit is set.

Example 4: Configure the 1747-SCNR Scanner with the 1746-BAS Series B Interface Module

The following example discusses how to configure the 1747-SCNR scanner with the 1746-BAS Series B interface module.

Hardware Setup

The hardware setup for this examples includes a computer with RSLogix500, RSLinx, RSNetWorx for ControlNet software, and a 1784-KTCX15 interface card.

The chassis configuration includes a 1747-ACNR15 module in slot 0, 1746-IA16 module in slot 1, 1746-OB16 module in slot 2, and 1746-BAS module in slot 3.

Configure the ControlNet Network with RSNetWorx for ControlNet Software

Follow the procedure below to configure the ControlNet network using RSNetWorx for ControlNet software.

1. Start RSNetWorx for ControlNet software by double clicking its icon.

You see this screen:

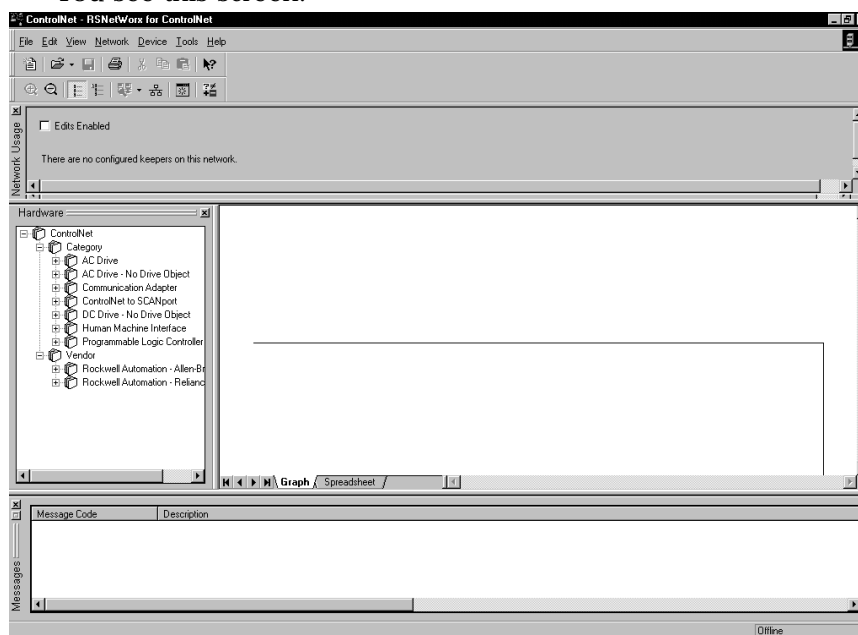

At this time, you can configure your ControlNet network offline and then download it to the network. But in this example, we go online and configure the network.

- Go online by clicking the Online icon or by clicking the Network menu and selecting Online.

You see the Browse for Network window. In this window, you must select the communication path previously configured in RSLinx for communicating with your ControlNet network. For this example, a 1784-KTCX15 ControlNet PC card is used.

- Click the 1784-KTCX15 card to select it.
- Click OK.

The software attempts to communicate with all possible node numbers on the network, from 1 to 99. The online network screen appears. For this example, the screen should show node 99 as the programming terminal as shown below.

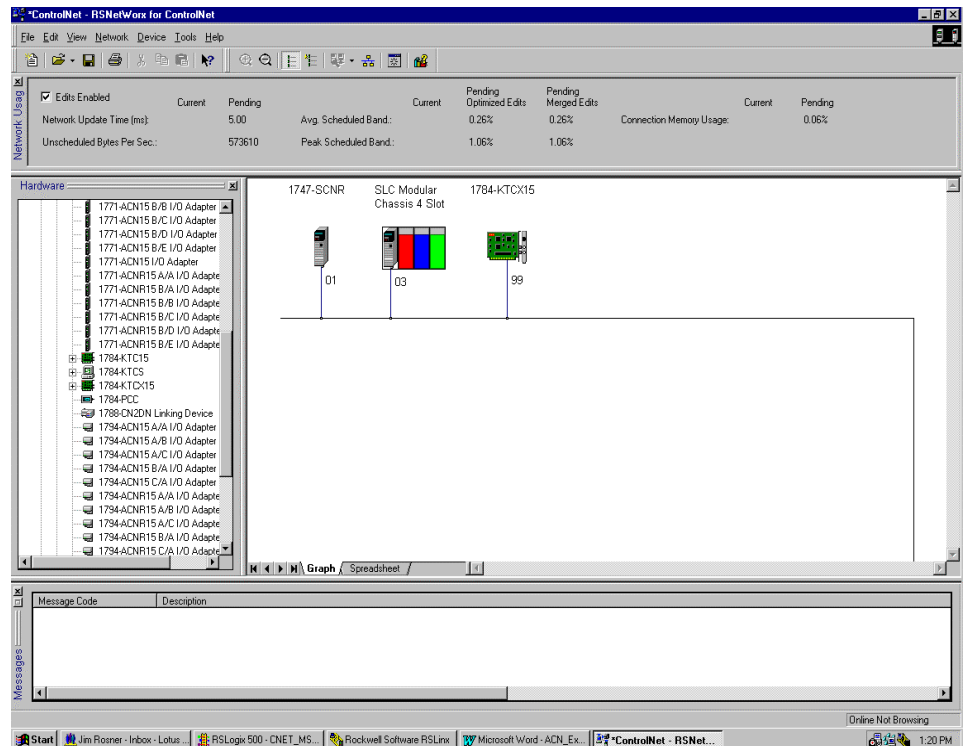

Node 1 is the 1747-SCNR scanner and node 3 is the 1747-ACNR15 module. The 1747-ACNR15 resides in slot 0 of its chassis, while slot 1 contains a 1746-IA16, slot 2 contains a 1746-OB16, and slot 3 contains a 1746-BAS. For this example, two separate ControlNet connections will be configured. The first will be a Discrete 16 Bit Exclusive Owner rack connection for the two discrete I/O modules. The second will be an Exclusive Owner - Advanced Module Connection to the 1746-BAS module. Before we create these connections, we should verify the chassis configuration for the 1747-ACNR15 module.

To do this:

5. Right-click the 1747-ACNR15 module.
6. Choose Edit Chassis and verify that the chassis configuration is as follows:
 - slot 0: 1747-ACNR15
 - slot 1: 1746-IA16
 - slot 2: 1746-OB16
 - slot 3: 1746-BAS

If the chassis is not already configured, manually configure it by dragging the appropriate modules from the list on the right to the proper slot on the left of the chassis configuration screen. When online, the software reads the module types for you. When this is complete, click APPLY and then OK.

Configure a Rack Connection

We are now ready to configure the necessary ControlNet connection so we can read/write data from the SLC processor to the discrete I/O modules and to the analog I/O module.

1. Right-click the 1747-SCNR scanner and choose Scanlist Configuration.

You are prompted to enter the Edit mode.

2. Click YES.

You see the following screen:

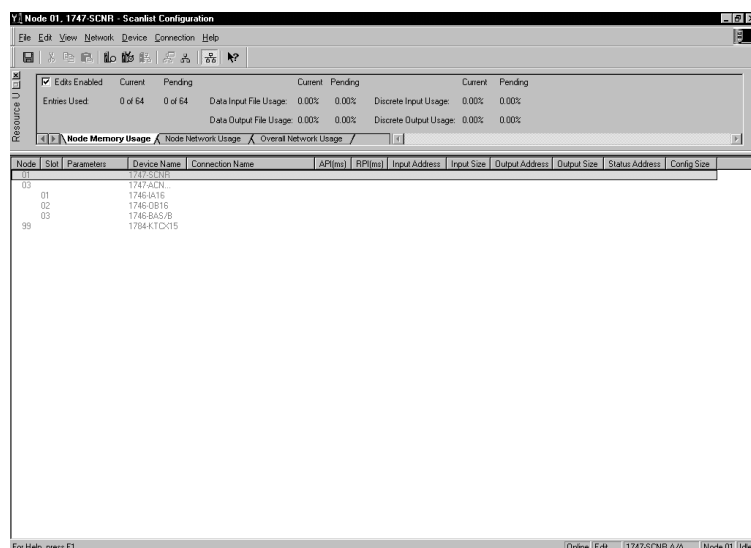

The 1747-SCNR and 1747-ACNR15 modules are shown as nodes 1 and 3, respectively. The three I/O modules are under the 1747-ACNR15 in slots 1 through 3 of the 1747-ACNR15 chassis.

3. To establish a 16-bit rack connection to the 1747-ACNR15 chassis, right-click the 1747-ACNR15 module and choose Insert Connection.

You see the following window:

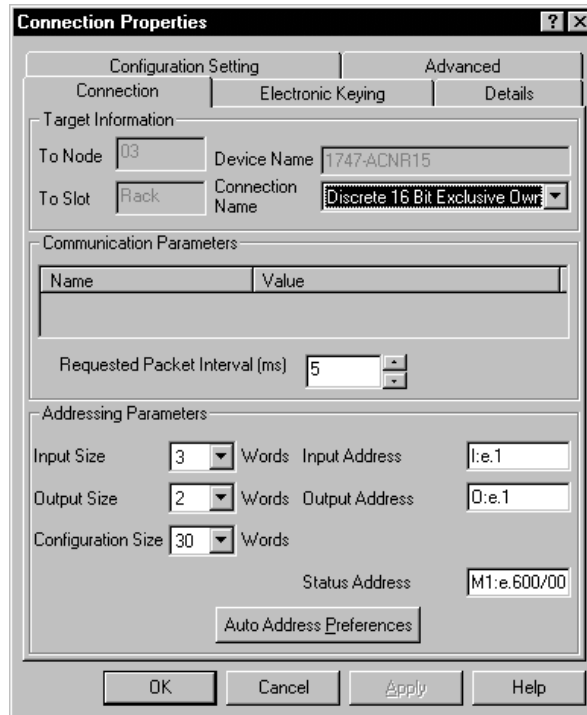

Note that addresses in the Connection Properties window are already displayed in the fields. To have RSNetWorx for ControlNet software choose the next available, valid I/O or M-file addresses for all connections:

- a. Click the Auto Address Preferences button.
- b. Click the box next to Enable Automatic Addressing on Insert so that a check mark appears in the box.
- c. Click OK.

The Connection Name by default is Discrete 16 Bit Exclusive Owner. This is the 16-bit rack connection we want. The first available I/O addresses are I:3.1 and O:3.1, where the 1747-SCNR is in slot 3 of the processor chassis. The first available starting I/O addresses have been placed into the Input Address and Output Address fields by RSNetWorx for ControlNet software, because automatic addressing was previously selected in the Auto Address Preference screen.

Words I:3.0 and O:3.0 are reserved. Note that the input data from the 1746-IA16 module is found in the processor's input image word I:3.3, the output data written to the 1746-OB16 module will be from the processor's output image word O:3.2.

IMPORTANT

There is a two word offset for input data for rack connections. Therefore, for this example, the input data for the input module in slot 1 of the remote 1747-ACNR15 chassis will be written to I:3.3 in the SLC processor's input image.

The starting input address configured in RSNetWorx for ControlNet software for this rack connection was I:3.1, but I:3.1 and I:3.2 are used for status information. Therefore, the actual input data begins after the two words of status information. I:3.4 is not used in this example because an output module resides in slot 2.

Also, note that there is no offset for the outputs in a rack connection. O:3.2 is the output image word written to the output module located in slot 2 of the 1747-ACNR15 chassis. In addition, no offset applies to module connections at all.

You must also enter a value in the Status Address field. This field supplies Connection Status information to the processor for each unique connection. The bit addresses for this field must be even numbers, because two consecutive bits are used as status for each connection. The even numbered bit indicates whether the connection is open or closed and the odd numbered bit indicates whether the connection is in normal operation or Idle mode. In this example, the starting address chosen is the first available bit pair, M1:3.600/00.

You have successfully configured a rack connection to the remote chassis to communicate with the two discrete I/O modules. At this point, you may also configure the state of the outputs in the remote ControlNet chassis when the processor is placed into the Program Mode or if communications is lost to the remote chassis. This is optional. The default is to turn all outputs off when one of the two conditions occur. To select other options:

1. Click the Advanced tab in the Connection Properties window.

You see the following window.

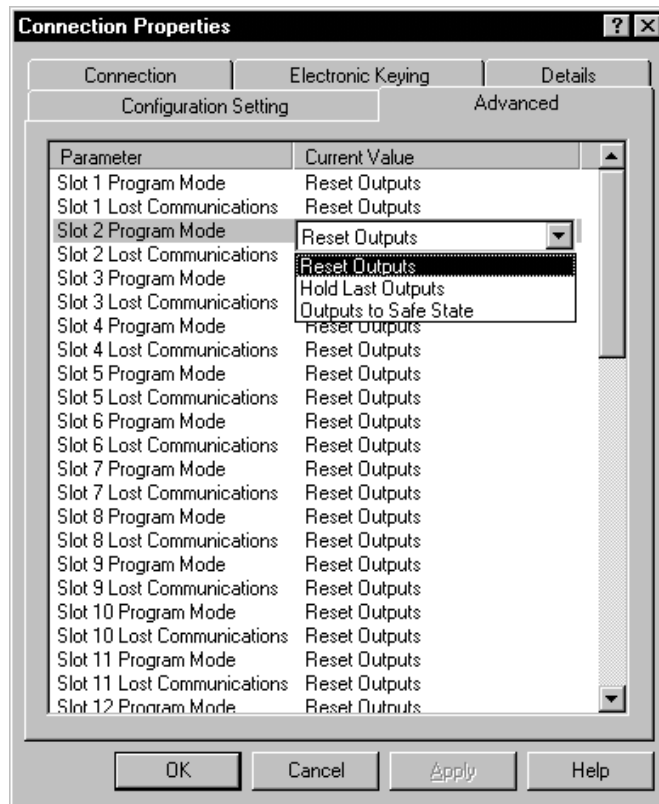

By default, outputs in all slots in the remote chassis are reset if the processor is placed into the Program mode or if communications is lost for any reason. Two other choices are offered:

- Hold Last State - all outputs remain in their last state if one of the two conditions occur
- Safe State - lets you to choose exactly the state of each output

If Safe State is selected, you must click the Configuration Settings tab and enter your Safe State data for each output word in decimal. Then, whenever the SLC processor is placed into the Program Mode or if communications is lost to the 1747-ACNR15 adapter, the outputs will revert to the Safe State data you entered for each output word.

2. Click APPLY.
3. Click OK to accept the rack connection.

Configure a Module Connection

Next, we need to configure a module connection for the 1746-BAS module.

1. Right-click the 1746-BAS module in the Scanlist Configuration window.
2. Select Insert Connection.

A Connection Properties window appears.

3. Choose Exclusive Owner - Advanced for the connection name.

For this example, we must choose M-file addresses for this type of connection. The series B module communicates via eight I/O words and 64 M1 and 64 M0 file words. These Basic module M-file words are independent of the 72 M-file words transferred to and from the Basic module. These 72 M0 and 72 M1 file words reside in the 1747-SCNR scanner and are used to store the data sent to the 1747-ACNR15 module from the SLC-5/04 processor and to store the data received from the 1747-ACNR15 for the SLC-5/04 processor.

The M0-file words in the 1747-SCNR scanner, which are assigned in the Connection Properties screen, are M0:3.3 through M0:3.74. These are the 72 words sent from the SLC-5/04 processor to the 1747-SCNR. Words M1:3.3 through M1:3.74 are the 72 words received from the 1747-ACNR15. M-file words M1:3.0 through M1:3.2 and M0:3.0 through M0:3.2 are reserved (please refer to Chapter 2 of this manual for details). The next available Status Address is M1:3.600/02, since bits 0 and 1 are used for the rack connection.

The Connection Properties window for the module connection should look like the following:

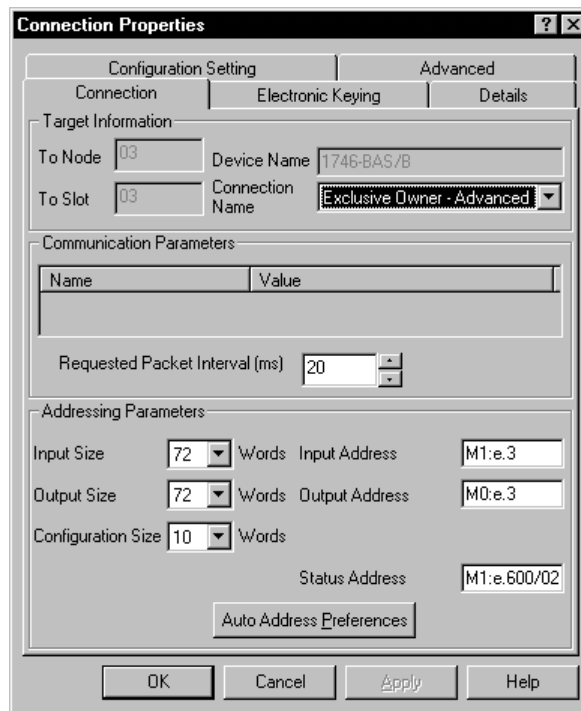

We now have to configure this connection for the eight I/O words and the 64 M0/M1 file words.

4. Click the Advanced tab in the Connection Properties window.

You see this screen:

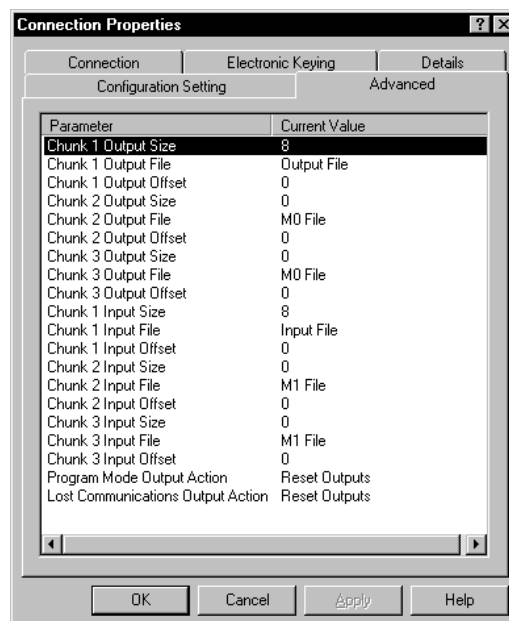

By default, the Chunk 1 Output File is the output image file for the Basic module and the Chunk 1 Input File is the input image file for the Basic module. We must then assign the Chunk 2 Output File as the Basic module's M0 file and the Chunk 2 Input File as the Basic module's M1 file. The size for each of these files is 64 words. The total number of words transferred bi-directional between the SLC processor and the Basic module will be 72. The first eight will be the Basic module's I/O image and the last 64 words will be the Basic module's M-file words. This order is determined by the Chunk numbers. This Advanced screen should then look as follows:

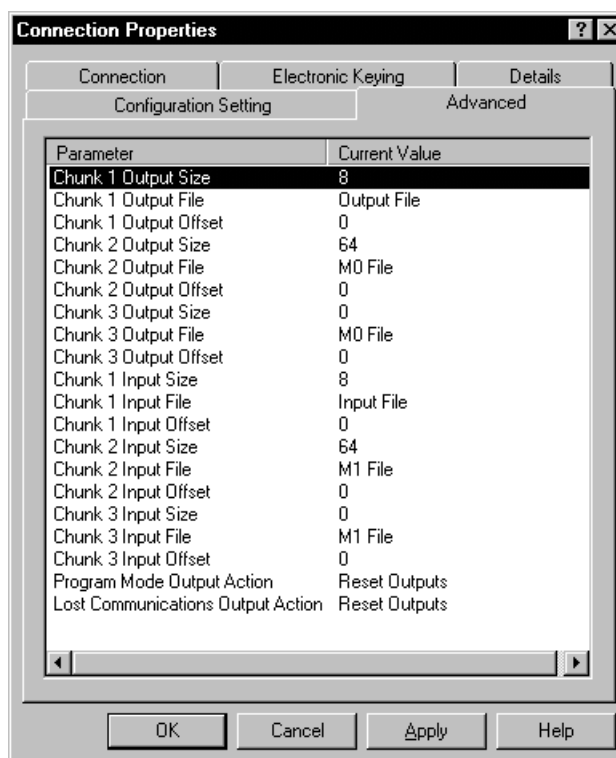

Safe State data is available under the Configuration Settings tab. For 1747-BAS module connections, it is recommended that outputs be reset to 0 when the SLC processor is placed into the Program mode or if communications is lost to the 1747-ACNR15 module. The Hold Last State option is not available for the 1747-BAS module.

5. Click APPLY.
6. Click OK.

The Connection Properties window will close and the Scanlist Configuration window appears and looks as follows:

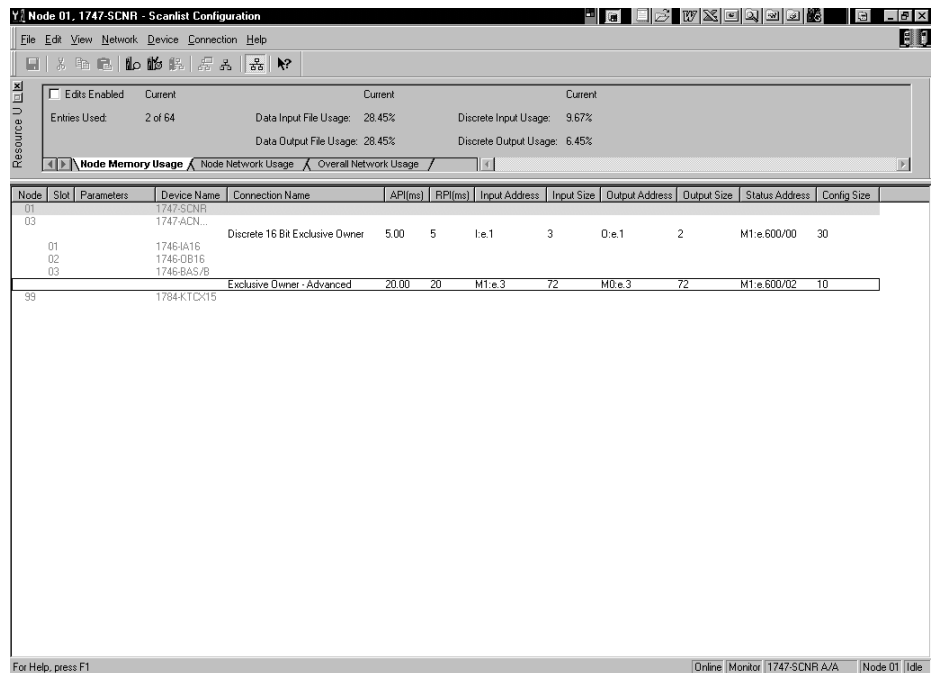

You have successfully configured your two connections to read/write data between the SLC processor and the remote ControlNet chassis. All that remains is to save the configuration to the network keeper, which in this case is the 1747-SCNR scanner.

1. Click the Save icon or click the File menu and then Save.

You are prompted to Optimize and re-write schedule for all connections.

2. Click OK.
3. Click YES to the warning message.

Your network configuration information is written to the network keeper.

The display on the front of your 1747-SCNR scanner should show an image of a full glass next to the word I/O. This indicates that all configured connections have been successfully downloaded to the scanner. In addition, the A and OK LEDs should be solid green and the B LED should be off, unless you are using the redundant media option, which is not being used in this example. The 1747-ACNR15 module should be displaying that it is active (ACTV) and its LEDs should be solid green for A and OK and the B LED should be off.

Creating Ladder Logic and Basic Module Program

The final step is to write a ladder program for the SLC processor and a Basic program for the Basic module. After downloading the program to your processor and to your basic module, place the processor into the Run mode and run your Basic program as well. Your programs should now be able to read data from the 1746-IA16 in word I:3.3 and write to the 1746-OB16 in word O:3.2.

The attached basic program contains a CALL 23 interrupt CALL for PRT1 and a CALL 22 interrupt CALL for PRT2. The CALL 23 sends data out PRT1 when data is received from the SLC processor and CALL 22 transfers data sent in PRT2 to the SLC processor. Remember, the first eight words beginning with M1:3.3 and M0:3.3 are from the Basic module's Input and Output image. The following 64 words are from the Basic module's M1 and M0 files.

The handshaking required between the SLC processor and the Basic module to transfer data, is shown in the ladder logic program to follow. Refer to the 1746-BAS BASIC Language Reference Manual, publication 1746-RM001 for a complete description of CALL 22 and 23, as well as the required handshaking. The only difference in the handshake logic when using these Basic module CALLs is that the I/O image words used for the handshaking are stored in the 1747-SCNR's M-files, so they appear as M-file addresses in the ladder logic instead of I/O addresses.

Connect an RS-232 cable between PRT1 and PRT2 on the Basic module. A 1747-CP3 cable will work for this purpose. When up to 64 words of data are placed into SLC processor's data table beginning at N12:0, it will be sent to the 1747-SCNR scanner, then to the Basic module via ControlNet and the 1747-ACNR15 and will ultimately be sent out PRT1 of the BAS module. If you used a cable to loop the data back in PRT2, this data will be sent to the 1747-SCNR scanner via ControlNet and will ultimately appear in the SLC processor's data table beginning with address N13:0.

Note that your ladder program should also contain an unconditional rung with an OTE instruction addressed to the 1747-SCNR scanner's Run/Idle bit, O:3.0/10 for this example. When the SLC processor is placed into the Run mode, this rung will set the 1747-SCNR scanner's Run/Idle bit and place the scanner into the Run mode as well. The scanner will begin executing the configured connections when the Run/Idle bit is set.

A sample Basic module program using CALL 23 for PRT1 and CALL 22 for PRT2 follows, along with the necessary ladder logic to handshake with the module for these CALLs. When the SLC processor is placed into the Run mode, it in turn places the 1747-SCNR scanner into the Run mode as well by virtue of the unconditional OTE rung described above.

When the Basic module is also placed into the Run mode, any data placed into the SLC processor's data table beginning with N12:0 is sent to the 1747-SCNR scanner, which sends it to the 1747-ACNR15 module via ControlNet and then to the Basic module. The Basic module sends the data out PRT1 and this data is looped right back in the Basic module's PRT2.

The module sends the data to the 1747-ACNR15 module, which sends it to the 1747-SCNR scanner via ControlNet. The SLC processor then retrieves this data and places it into its data table beginning at N13:0.

Example of Basic Module Program

```

0 REM BTRAN V1.03, C:\ABBASIC\BDS\CNET_TST.BDL, 11-22-99
02:52pm
10 REM Test Program for CNET
20 MODE(PRT1,9600,N,8,1,N,R)
30 MODE(PRT2,9600,N,8,1,N,R)
40 PUSH 2
50 CALL 37
60 PUSH 2
70 CALL 96
80 REM CALL 23 for PRT1
90 PUSH 2
100 REM SEND DATA OUT PRT1
110 PUSH 1
120 REM GET DATA FROM M0 FILE
130 PUSH 0
140 REM NO OFFSET
150 PUSH 0
160 REM NO STRING USED
170 PUSH 1
180 REM ENABLE BYTE SWAPPING
190 CALL 23
200 POP S1
210 REM STATUS OF CALL 23 SETUP
220 IF (S1<>0) THEN P. "UNSUCCESSFUL CALL 23 SETUP"
230 REM CALL 22 FOR PRT2
240 PUSH 2
250 REM GET DATA FROM PRT2
260 PUSH 126
270 REM MAXIMUM OF 126 CHARACTERS PER TRANSFER

```

```
280 PUSH 13
290 REM CR TERMINATION CHARACTER
300 PUSH 1
310 REM SEND DATA TO M1 FILE
320 PUSH 0
330 REM NO OFFSET
340 PUSH 0
350 REM NO STRING
360 PUSH 1
370 REM ENABLE BYTE SWAPPING
380 CALL 22
390 POP S2
400 REM CALL 22 SETUP STATUS
410 IF (S2<>0) THEN P. "UNSUCCESSFUL CALL 22 SETUP"
420 GOTO 420
```

The next example contains ladder logic to handshake with the module for CALLs 23 and 22.

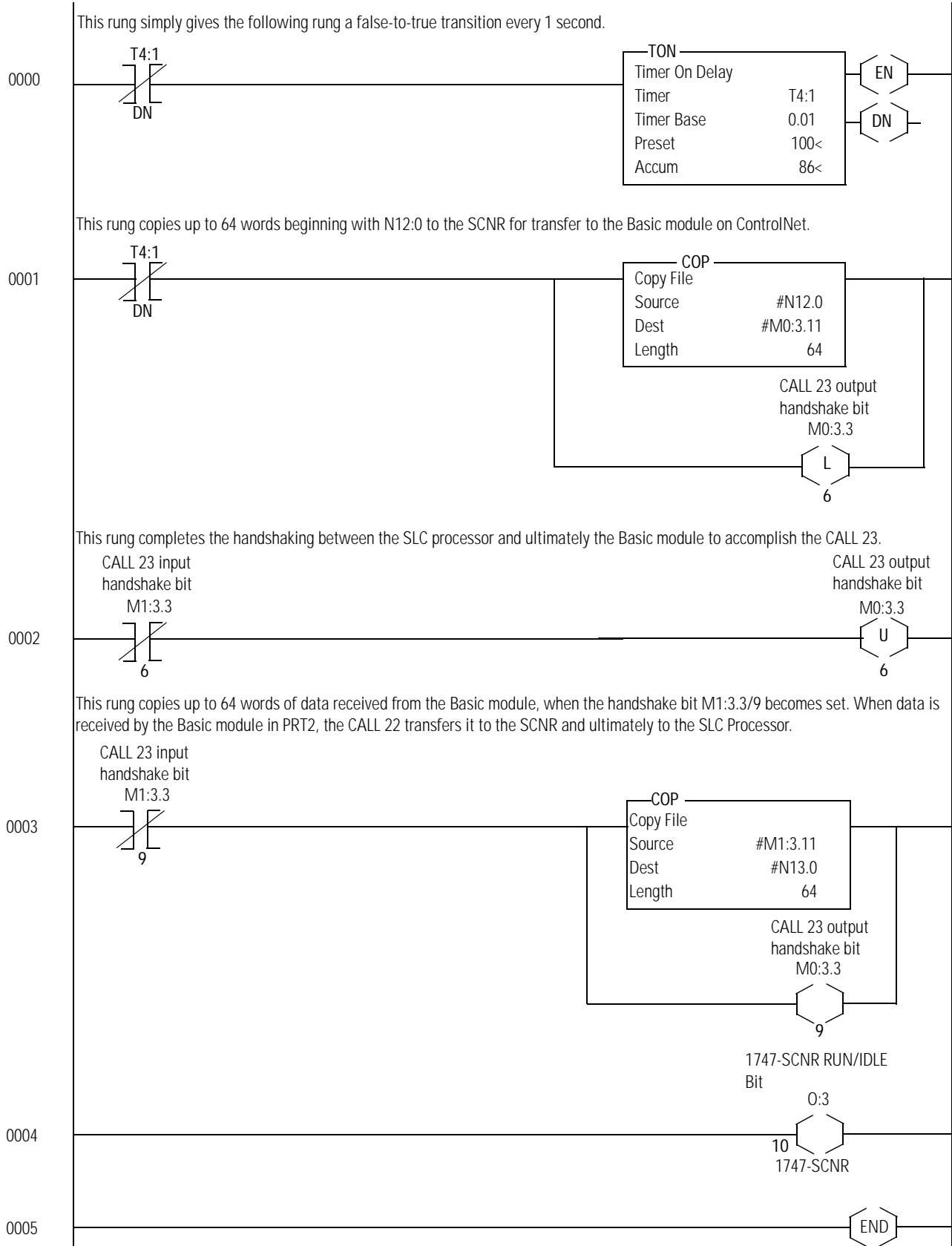

Example 5: Configure the 1747-SCNR Scanner with the 1794-IE4XOE2 Analog Combo Module

The following example discusses how to configure the 1747-SCNR scanner with the 1794-IE4XOE2 analog combo module.

Hardware Setup

The hardware setup for this examples includes a computer with RSLogix500, RSLinx, RSNetWorx for ControlNet software, and a 1784-KTCX15 interface card. The chassis configuration includes a 1794-ACNR15 module, a 1794-IB16 module in slot 0, 1794-OB16 module in slot 1, and 1794-IE4XOE2 module in slot 2.

Configure the ControlNet Network with RSNetWorx for ControlNet Software

Follow the procedure below to configure the ControlNet network using RSNetWorx for ControlNet software.

1. Start RSNetWorx for ControlNet software by double-clicking its icon.

You see this screen:

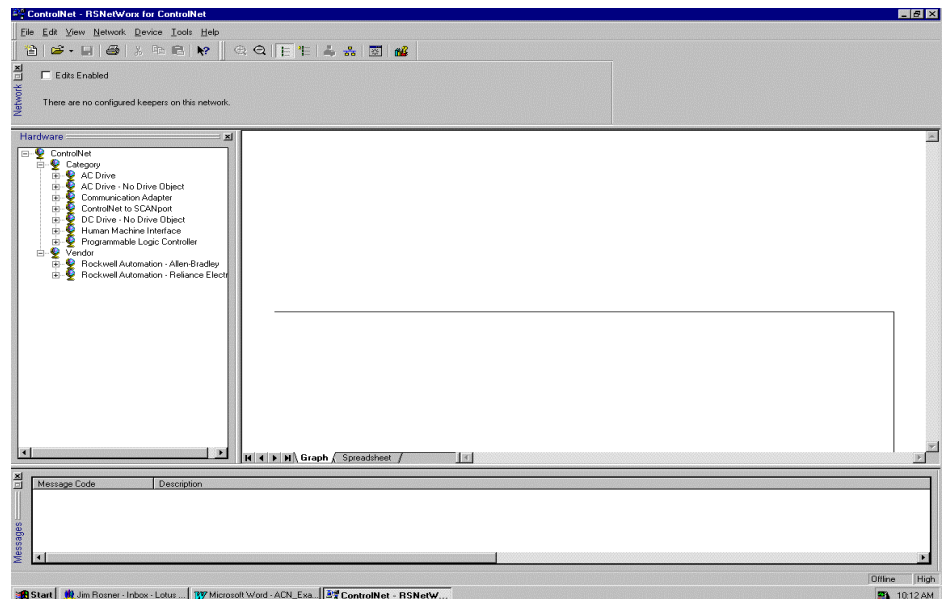

At this time, you can configure your ControlNet network offline and then download it to the network. But in this example, we go online and configure the network.

2. Go online by clicking the Online icon or by clicking the Network menu and selecting Online.

You see the Browse for Network window. In this window, you must select the communication path previously configured in RSLinx for communicating with your ControlNet network. For this example, a 1784-KTCX15 ControlNet PC card is used.

3. Click the 1784-KTCX15 card to select it.
4. Click OK.

The software attempts to communicate with all possible node numbers on the network, from 1 to 99. The online network screen appears. For this example, the screen should show node 99 as the programming terminal as shown.

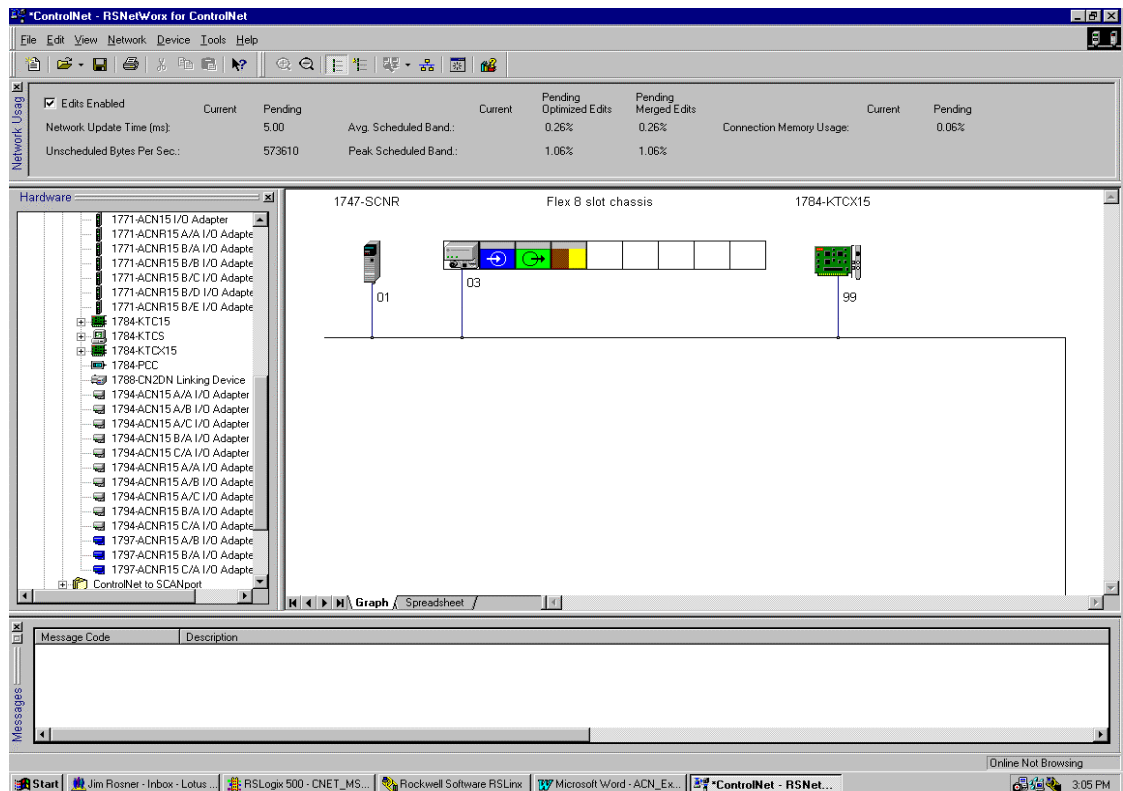

Node 1 is the 1747-SCNR scanner and node 3 is the 1794-ACNR15 module. Slot 0 contains a 1794-IB16, slot 1 contains a 1794-OB16 module and slot 2 contains a 1794-IE4XOE2 module. For this example, two separate ControlNet connections are configured. The first is a Discrete Exclusive Owner rack connection for the two discrete I/O modules. The second is a Module Connection to the 1794-IE4XOE2 4 input/2 output analog module. Before we create these connections, we should verify the chassis configuration for the 1794-ACNR15 module. To do this:

5. Right-click the 1794-ACNR15 module.
6. Choose Edit Chassis and verify that the chassis configuration is as follows:
 - : 1794-ACNR15
 - slot 0: 1794-IB16
 - slot 1: 1794-OB16
 - slot 2: 1794-IE4XOE2

If the chassis is not already configured, manually configure it by dragging the appropriate modules from the list on the right to the proper slot on the left of the chassis configuration screen. When this is complete, click APPLY and then OK.

Configure a Rack Connection

We are now ready to configure the necessary ControlNet connection so we can read/write data from the SLC processor to the discrete I/O modules and to the analog I/O module.

1. Right-click the 1747-SCNR scanner and choose Scanlist Configuration.

You are prompted to enter the Edit mode.

2. Click YES.

You see the following screen:

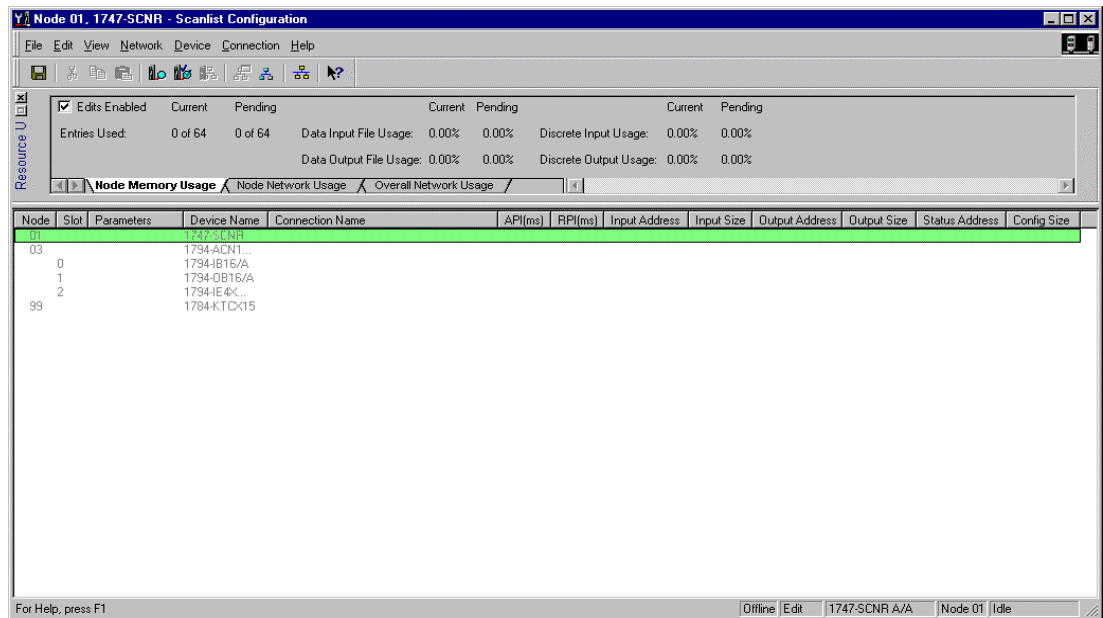

The 1747-SCNR and 1794-ACNR15 module are shown as nodes 1 and 3, respectively. The three I/O modules are under the 1794-ACNR15 module in slots 0 and 2 of the 1794-ACNR15 system.

- To establish a 16-bit rack connection to the 1794-ACN515 chassis, right-click the 1794-ACNR15 module and choose Insert Connection to see the following window.

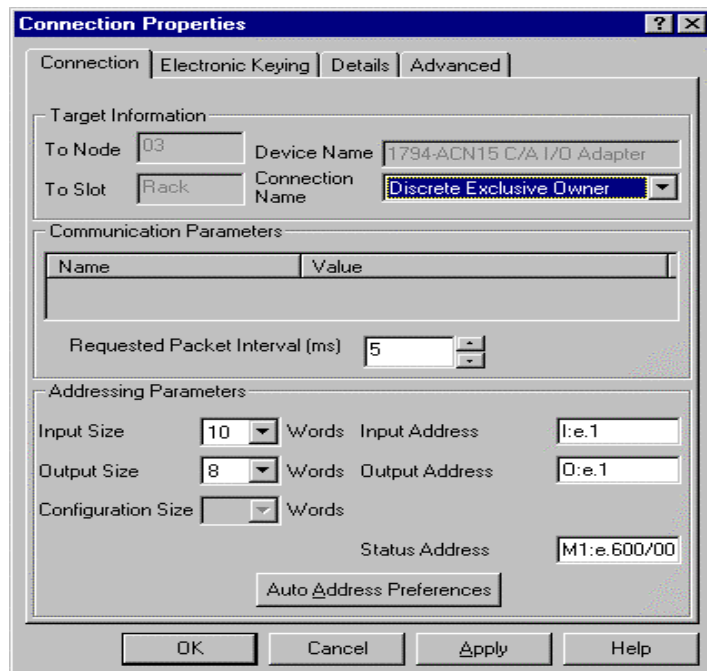

Note that addresses in the Connection Properties window are already displayed in the fields. To have RSNetWorx for ControlNet software choose the next available, valid I/O or M-file addresses for all connections:

- a. Click the Auto Address Preferences button.
- b. Click the box next to Enable Automatic Addressing on Insert so that a check mark appears in the box.
- c. Click OK.

The Connection Name by default is Discrete Exclusive Owner. This is the rack connection we want. The first available I/O addresses are I:3.1 and O:3.1, where the 1747-SCNR is in slot 3 of the processor chassis. The first available starting I/O addresses have been placed into the Input Address and Output Address fields by RSNetWorx for ControlNet software, because automatic addressing was previously selected in the Auto Address Preference screen.

Words I:3.0 and O:3.0 are reserved. Note that the input data from the 1794-IB16 module is found in the processor's input image word I:3.3, the output data written to the 1794-OB16 module is from the processor's output image word O:3.2.

IMPORTANT

There is a two-word offset for input data for rack connections and module connections when working with a 1794 Flex ControlNet adapter. Therefore, for this example, the input data for the input module in slot 0 of the remote 1794-ACNR15 system is written to I:3.3 in the SLC processor's input image.

The starting input address configured in RSNetWorx for ControlNet software for this rack connection was I:3.1, but I:3.1 and I:3.2 are used for status information. Therefore, the actual input data begins after the two words of status information. I:3.4 is not used in this example because an output module resides in slot 2.

Also, note that there is no offset for the outputs in a rack connection. O:3.2 is the output image word written to the output module located in slot 1 of the 1794-ACNR15 chassis. In addition, this same offset scheme applies to module connections for Flex I/O on ControlNet. For this example, the input and output data for the 1794-IE4XOE2 is located in M1:3.5 through M1:3.8 and M0:3.3 and M0:3.4.

You must also enter a value in the Status Address field. This field supplies Connection Status information to the processor for each unique connection. The bit addresses for this field must be an even number, because two consecutive bits are used as status for each connection. The even numbered bit indicates whether the connection is open or closed and the odd numbered bit indicates whether the connection is in normal operation or Idle mode. In this example, the starting address chosen is the first available bit pair, M1:3.600/00.

You have successfully configured a rack connection to the remote Flex adapter to communicate with the two discrete I/O modules. At this point, you may also configure the state of the outputs in the remote ControlNet chassis when the processor is placed into the Program Mode or if communications is lost to the remote chassis. This is optional. The default is to turn all outputs off when one of the two conditions occur. To select other options:

1. Click the Advanced tab in the Connection Properties window.

You see the following window.

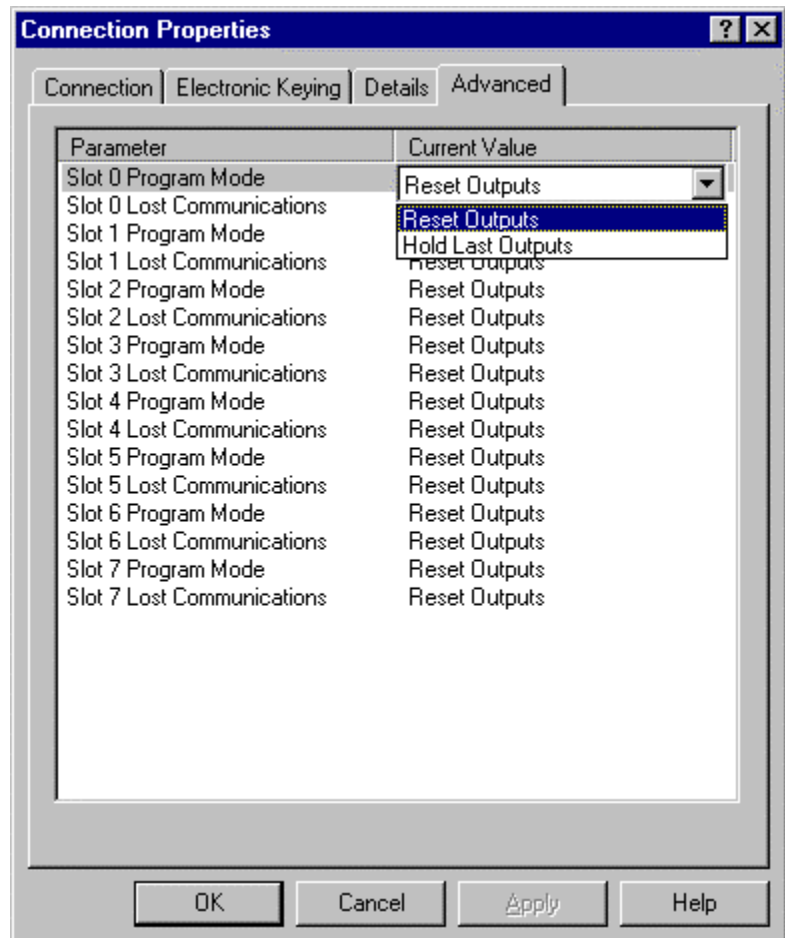

By default, outputs in all slots in the remote chassis are reset if the processor is placed into the Program mode or if communications is lost for any reason. The other choice offered is Hold Last State, which means all outputs remain in their state should one of the two conditions occur.

2. Click APPLY.
3. Click OK to return to the Scanlist Configuration screen.

Configure a Module Connection

Next, we need to configure a module connection for the 1794-IE4XOE2 4-input/2-output analog module.

1. Right-click the 1794-IE4XOE2 module in the Scanlist Configuration window.
2. Select Insert Connection.

A Connection Properties window appears.

3. Choose Exclusive Owner for the connection name.

For this example, we must choose M-file addresses for our 4 input/2 output analog module. The first available M-file addresses are M1:3.3 and M0:3.3. Words 0 through 2 are reserved.

The analog input data for the four analog inputs actually begin at M1:3.5, because the 1794-ACNR15 module sends two words of status information ahead of the actual data.

The output data for the two analog outputs does begin at address M0:3.3. The next available Status Address is M1:3.600/02, since bits 0 and 1 are used for the rack connection. The Connection Properties window for the module connection should look as follows:

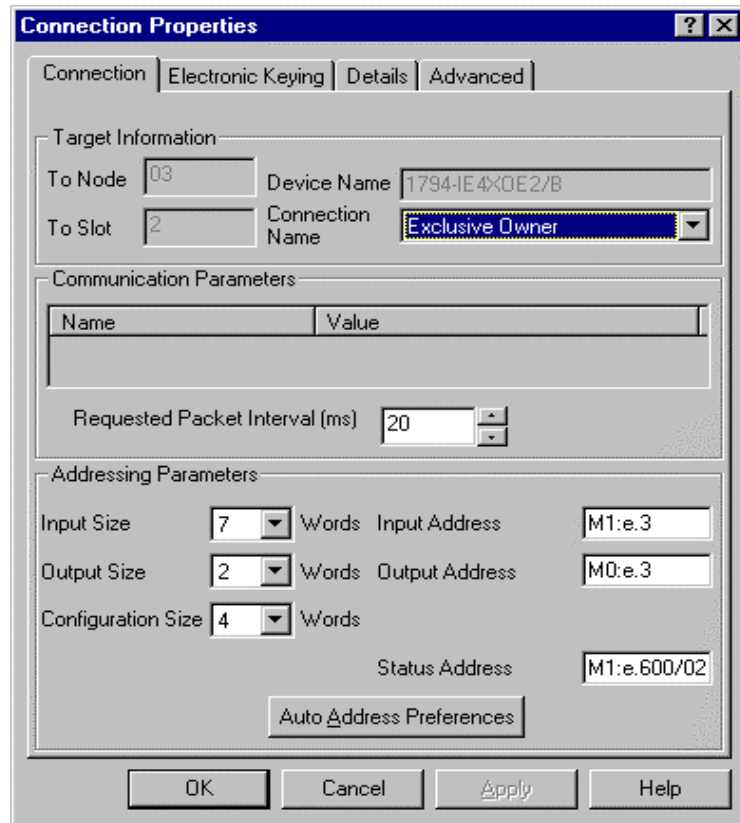

At this point, the state of the two analog outputs should be determined for the times when the SLC processor is placed into the Program mode or in the event that communications is lost to the 1794-ACNR15 module.

Set this state in the Advanced tab of the Connection Properties window for this module connection, provided you do not want the default settings of 0 decimal, which is the most common choice. This is the same procedure we performed for discrete outputs for the rack connection. The 1794-ACNR15 module only supports outputs set to 0 or Hold Last State if one of the two conditions occur.

4. Click APPLY.

- Click OK. The Connection Properties window closes and the Scanlist Configuration window appears and looks as follows:

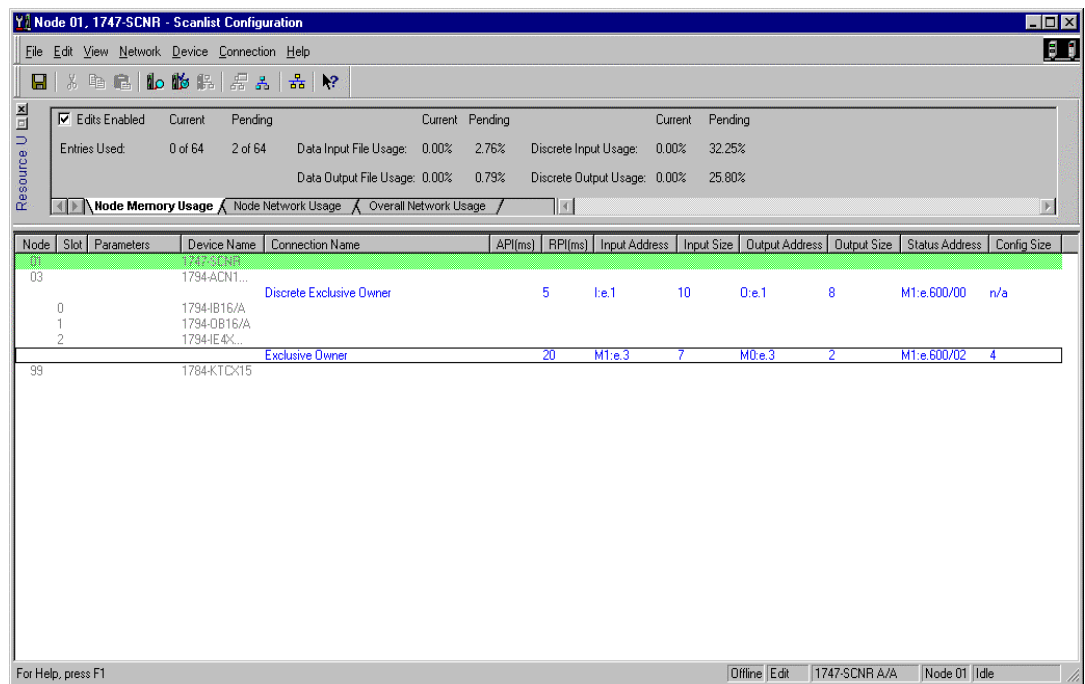

You have successfully configured your two connections to read/write data between the SLC processor and the Flex I/O on the ControlNet network. All that remains is to save the configuration to the network keeper, which in this case is the 1747-SCNR scanner.

- Click the Save icon or click the File menu and then Save.

You are prompted to Optimize and re-write schedule for all connections.

- Click OK.
- Click YES to the warning message.

Your network configuration information is now written to the network keeper.

The display on the front of your 1747-SCNR scanner should show an image of a full glass next to the word I/O. This indicates that all configured connections have been successfully downloaded to the scanner. In addition, the A and OK LEDs should be solid green and the B LED should be off, unless you are using the redundant media option, which is not being used in this example. The 1794-ACNR15 module should be displaying a green COMM A and STATUS LED, while COMM B should be off.

Creating Ladder Logic and Basic Module Program

The final step is to write a ladder program for the SLC processor, including the 1747-SCNR scanner for slot 3 of the processor's chassis. After downloading the program to your processor, place the processor into the Run mode. Your programs should now be able to read data from the 1794-IB16 module 00000000 in word I:3.3 and write to the 1794-OB16 module in word O:3.2.

The analog input data resides in words M1:3.5 through M1:3.8, while the analog output data must be placed in words M0:3.3 and M0:3.4. M1:3.9 is the seventh word received from the analog module. It contains status bits for the analog I/O channels. Please refer to your 1794-IE4XOE2 analog combo module documentation for additional details.

Example 6: Creating Peer-to-Peer Scheduled Connections Between 1747-SCNR ControlNet Scanners

The following example discusses how to create peer-to-peer scheduled connections between 1747-SCNR ControlNet scanners.

Hardware Setup

The hardware setup for this examples includes a computer with RSLogix500, RSLinx, RSNetWorx for ControlNet software, and a 1784-KTCX15 interface card. The chassis configuration includes an SLC-5/05 in slot 0, a 1747-SCNR scanner in slot 1, 1746-OB16 module in slot 2, and 1746-IV16 module in slot 3.

Configure the ControlNet Network with RSNetWorx for ControlNet Software

Follow the procedure below to configure the ControlNet network using RSNetWorx for ControlNet software.

1. Start RSNetWorx for ControlNet software by double-clicking its icon.

You see this screen:

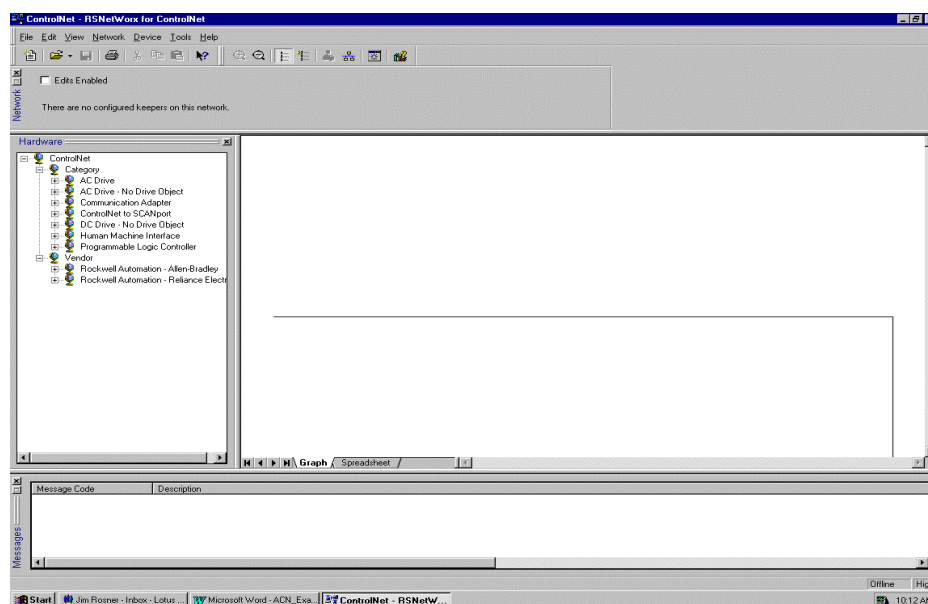

At this time, you can configure your ControlNet network offline and then download it to the network. But in this example, we go online and configure the network.

2. Go online by clicking the Online icon or by clicking the Network menu and selecting Online.

You see the Browse for Network window. In this window, you must select the communication path previously configured in RSLinx for communicating with your ControlNet network. For this example, a 1784-KTCX15 ControlNet PC card is used.

3. Click the 1784-KTCX15 card to select it.
4. Click OK.

The software attempts to communicate with all possible node numbers on the network, from 1 to 99. The online network screen appears. For this example, the screen should show node 99 as the programming terminal as shown.

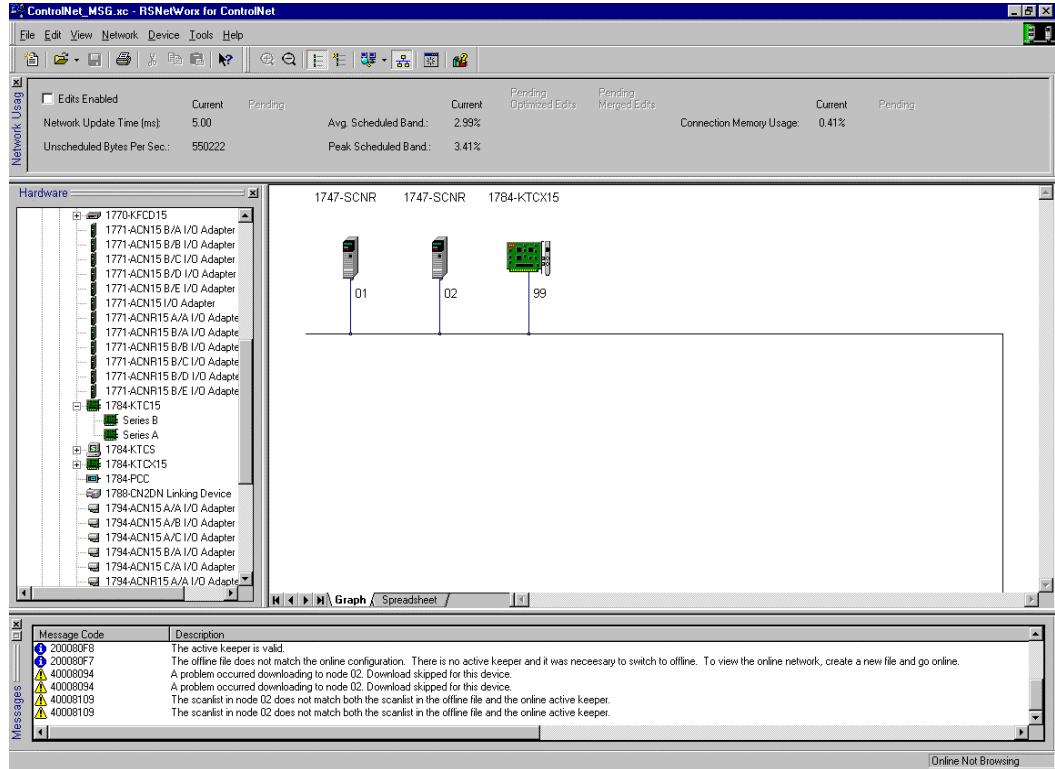

The two 1747-SCNR scanners are nodes 1 and 2 on the ControlNet network. For this example, a scheduled connection is configured for the 1747-SCNR module at node 1 to write 50 words to the 1747-SCNR scanner at node 2 and the 1747-SCNR scanner at node 2 writes 60 words to the 1747-SCNR scanner at node 1 with another scheduled connection.

In other words, the 1747-SCNR scanner at node 1 produces 50 words of data, received from the SLC processor in its chassis, and this data is consumed by the 1747-SCNR scanner at node 2. Also, the 1747-SCNR scanner at node 2 produces 60 words of data received from its processor and that data is consumed by the 1747-SCNR scanner at node 1. This producer/consumer model becomes more apparent when we actually create the necessary scheduled connections.

Configure a Scheduled Connection Between ControlNet Scanners

We are now ready to configure the necessary ControlNet connections to effectively transfer data between two SLC processors on a ControlNet network. These connections are scheduled connections, meaning that their throughput is deterministic and repeatable. If such data transfers between SLC processors on the ControlNet network do not require this type of determinism, then 1747-KFC15 modules may be used to let SLC processors to send unscheduled messages on a ControlNet network.

1. Right-click the 1747-SCNR scanner at node 1.
2. Choose Scanlist Configuration. You are prompted to enter the Edit mode.
3. Click YES.

You see the following screen:

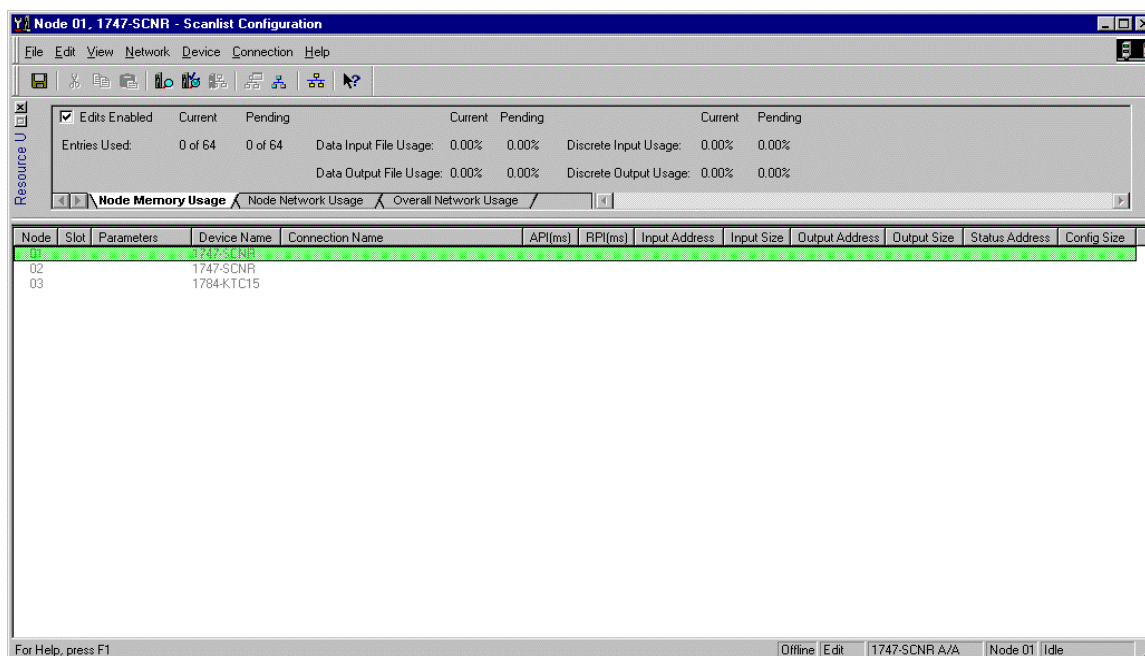

As you can see, the two 1747-SCNR ControlNet scanners are shown as nodes 1 and 2. To establish a scheduled peer-to-peer connection so node 1 can send/produce 50 words of data for node 2:

4. Right-click the 1747-SCNR scanner at node 2.
5. Choose Insert Connection.

You see the following window:

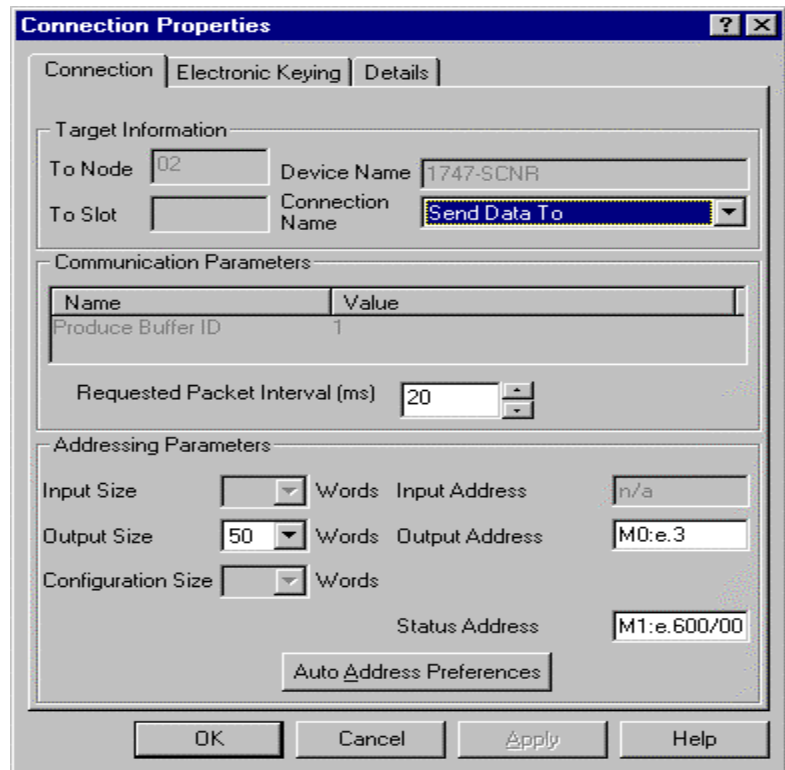

Note that addresses in the Connection Properties window are already displayed in the fields. To have RSNetWorx for ControlNet software choose the next available, valid I/O or M-file addresses for all connections:

- a. Click the Auto Address Preferences button.
- b. Click the box next to Enable Automatic Addressing on Insert so that a check mark appears in the box.
- c. Click OK.

In general, we recommend that you create connections for a particular device in its own Scanlist, but under the other devices in that Scanlist. Then, RSNetWorx for ControlNet software knows enough about that connection to create the other matching connection in the other device's Scanlist.

For this example, we create a connection in the node 1 scanner's Scanlist to send/produce 50 words of data to the scanner at node 2 by entering this connection under node 2 in the Scanlist for node 1. RSNetWorx for ControlNet software automatically creates a receive/consumer data connection for 50 words under node 2 in the node 2 Scanlist. Everything in the Scanlist for node 1 is with respect to node 1. Therefore, if a connection to Send Data To is configured under node 2 in the node 1 Scanlist, this means that node 1 will send/produce data to node 2.

We do not recommended that you create connections, for example, under node 1 in its own Scanlist. RSNetWorx for ControlNet software will not know which node will consume the data it produces and will therefore not be able to create the other necessary connection. Making that connection is then your responsibility.

In this example, we want the 1747-SCNR scanner at node 1 to send/produce 50 words of data to the 1747-SCNR scanner at node 2. The connection name must be Send Data To. The number of words in this case is 50, but the valid range is between 1 and 240 words. The first available output address is M0:e.3, where e is the slot number of the 1747-SCNR scanner at node 1.

For this example, the 1747-SCNR scanner at node 1 takes 50 words of data copied to its M0 file by the SLC processor and sends/produces this data on the ControlNet network for the 1747-SCNR scanner at node 2 to receive/consume.

The SLC processor in the same chassis as the node 1 scanner will then need to copy 50 words of data to M0:3.3. The SLC processor in the same chassis as the node 2 scanner will need to copy 50 words from M1:1.3.

Please refer to the Hardware Setup section at the beginning of this application example to match the slot numbers in the M-file addresses to the slot numbers of the scanners in their respective chassis.

When you are finished configuring the connection in the Connection Properties screen:

6. Click APPLY.
7. Click OK.

You must also enter a value in the Status Address field. This field supplies Connection Status information to the processor. The starting bit addresses for this field must be an even number, because two consecutive bits are used as status for each connection. The even numbered bit indicates whether the connection is open or closed and the odd numbered bit indicates whether the connection is in normal operation or Idle mode. In this example, the address chosen for the first connection is the first available bit pair, M1:3.600/00.

The next connection automatically created by RSNetWorx for ControlNet software uses M1:3.600/02.

You must now save your Scanlist for node 1 to the network keeper.

8. Click the Save icon or click the File menu and then Save.

You will be prompted to Optimize and re-write schedule for all connections.

9. Click OK.
10. Click YES to the warning message.

To create a connection to have node 2 send 60 words of data to node 1, enter the Scanlist for node 2 and create a Send Data To connection under node 1. RSNetworx for ControlNet software will then automatically create a Receive Data connection under node 1 in the node 1 scanner's Scanlist. The SLC processor in the same chassis with the node 2 scanner will then need to copy 60 words of data to M0:1.3. The SLC processor in the same chassis with the node 1 scanner will then need to copy 60 words of data from M1:3.3.

Please refer to the Hardware Setup section at the beginning of this application example to match the slot numbers in the M-file addresses to the slot numbers of the scanners in their respective chassis. The starting Status Addresses for these connections will be M1:1.600/00 and M1:1.600/02.

You must now save your Scanlist for node 2 to the network keeper.

11. Click the Save icon or click the File menu and then Save.

You are prompted to Optimize and re-write schedule for all connections.

12. Click OK.
13. Click YES to the warning message

The Scanlist Configuration screens for nodes 1 and 2 should look as follows:

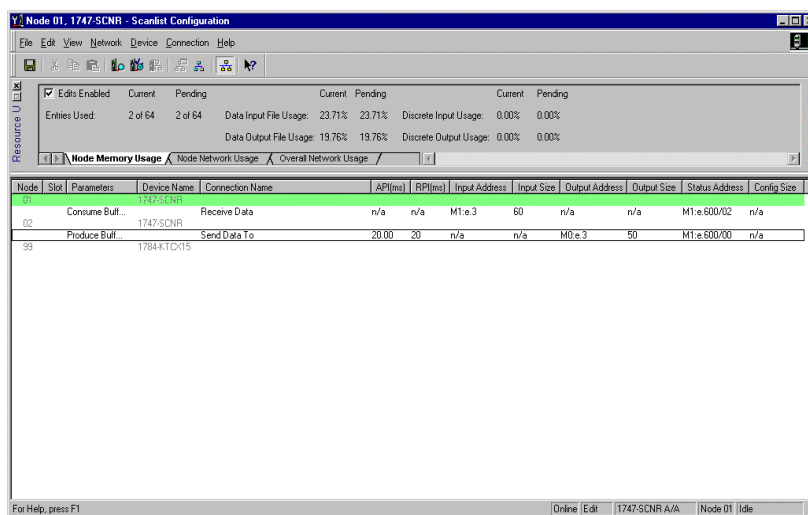

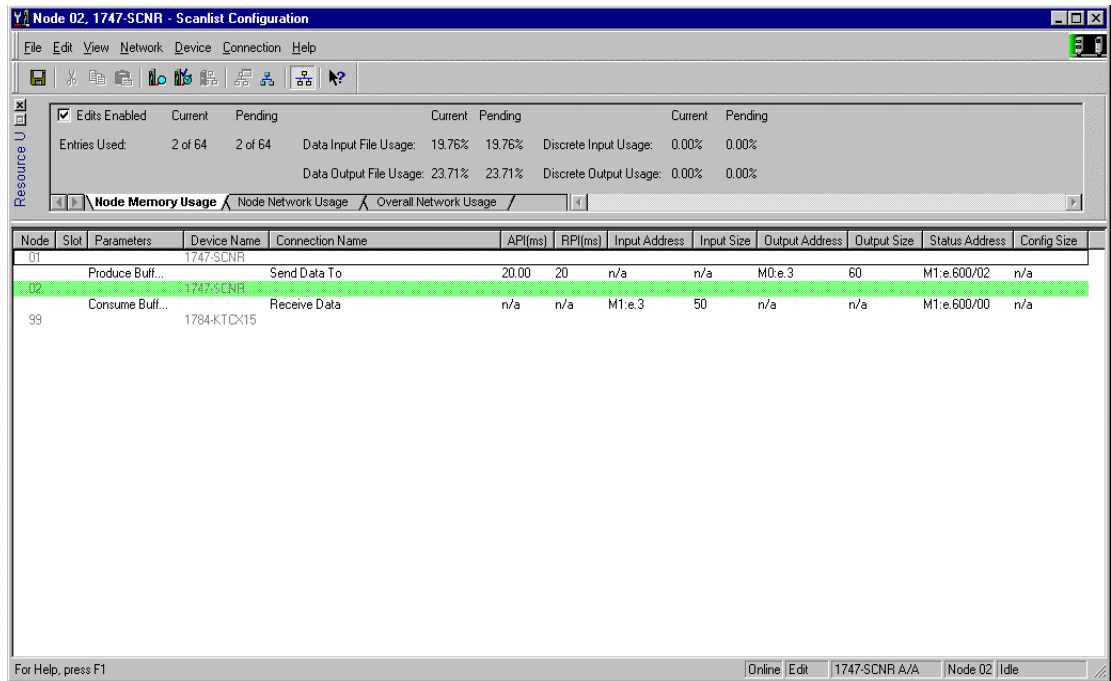

You have successfully configured peer-to-peer scheduled connections between two 1747-SCNR scanners. You have also saved this information to the active keeper on the network. If your ladder programs in the two SLC processors are correctly copying data to and from the M-files of each 1747-SCNR scanner and have an unconditional rung with an OTE instruction addressed to the Run/Idle bit for each scanner (bit 10 of the first output image word for the scanners, that is, O:3.0/10 for scanner node 1 and O:1.0/10 for scanner node 2), data transfers will begin when the two processors are placed into the Run mode.

When each SLC processor is placed into the Run mode, the 1747-SCNR scanner's Run/Idle bit must be set to a logical 1 to place each scanner into the Run mode to begin executing the configured connections.

The display on the front of your 1747-SCNR scanners should show an image of a full glass next to the word I/O. This indicates that all configured connections have been successfully downloaded to the scanner. In addition, the A and OK LEDs should be solid green and the B LED should be off, unless you are using the redundant media option, which is not being used in this example.

Numerics

1747-SCNR module

communicating with your SLC processor
2-2, 5-2

M0 file 2-9

M1 file 2-6

understanding ControlNet data transfer
2-3

understanding mapping 2-5

what it does 2-1

1747-SCNR mapping

discrete input file 2-5

discrete output file 2-8

M0 file 2-9

M1 file 2-6

A

adapters

alphanumeric display

troubleshooting 5-2

application examples

configure the 1747-SCNR module with
the 1746-BAS interface module
E-28

configure the 1747-SCNR module with
the 1746-IV16 input module
E-1

configure the 1747-SCNR module with
the 1746-N18 analog input
module E-19

configure the 1747-SCNR module with
the 1746-NIO4V input/output
module E-9

configure the 1747-SCNR module with
the 1794-IE4XOE2 I/O analog
combo module E-42

creating peer-to-peer scheduled
connections between
1747-SCNR ControlNet
scanners E-51

apply chassis power

troubleshooting 5-2

C

CIP client

management C-1, C-2

send a get attribute all request to
node 14 identity object
C-4

send a set attribute single request
C-8

SLC 500 ladder program exam-
ple C-10, C-14

SLC 500 processor target data
file (hex) C-11, C-15

SLC 500 ladder program C-6

SLC 500 processor data files (hex)
C-7

request transfer 2-10

communicating with your devices 2-9

CIP client request transfer 2-10

CIP unscheduled data server 2-10

I/O scheduled data transfer 2-9

communicating with your SLC processor 2-2, 5-2

configure scheduled data exchange

data transfer mapping 3-2

questions to ask 3-1

ControlNet data transfer

link layer services 2-4

scheduled data transfer operations on a
ControlNet network 2-3

understanding 2-3

unscheduled data transfer operations on
a ControlNet network 2-4

D

discrete output file 2-8

display mnemonics

E**examples**

- application E-1
- reset bit management D-1

explicit messages instruction

- for ControlNet networks 4-1

G**Get attribute**

- send an all request to node 14 identity object C-4

I**I/O scheduled data transfer 2-9****installing**

- connecting to network 1-5
- inserting into SLC chassis 1-3
- module features 1-1
- selecting node address 1-3
- SLC 500 I/O configuration 1-8

L**link layer services 2-4****local database**

- access using PLC-5 MSG instructions A-1
 - read and write access to 1747-SCNR scanner A-1
- ControlNet data files access using CIP messaging B-1
- read and write access to 1747-SCNR scanner B-1

M**M0 file mapping 2-9****M1 file mapping 2-6****mapping**

- understanding 2-5

MSG instructions

- read and write access to 1747-SCNR local database A-1

O**OK indicator**

- troubleshooting 5-3

P**purpose of 1747-SCNR scanner 2-1****R****reset bit management example D-1****S****scheduled data transfer operations on a ControlNet network 2-3****set attribute**

- send a single request C-8

SLC 500 ladder program C-6**SLC 500 processor data files (hex) C-7****status indicators and status display**

- troubleshooting 5-1

T**troubleshooting 5-1**

- alphanumeric display 5-2
- apply chassis power 5-2
- OK indicator and display mnemonics 5-3
- with status indicators and status display 5-1

U**unscheduled data transfer operations on a ControlNet network 2-4**



How Are We Doing?

Your comments on our technical publications will help us serve you better in the future. Thank you for taking the time to provide us feedback.

You can complete this form and mail (or fax) it back to us or email us at RADocumentComments@ra.rockwell.com

Pub. Title/Type ControlNet Scanner Reference Manual

Cat. No. 1747-SCNR Pub. No. 1747-RM623D-EN-P Pub. Date March 2006 Part No. 953014-25

Please complete the sections below. Where applicable, rank the feature (1=needs improvement, 2=satisfactory, and 3=outstanding).

| | | | |
|---|---|--------------|---------|
| Overall Usefulness 1 2 3 | How can we make this publication more useful for you? | | |
| | | | |
| | | | |
| | | | |
| Completeness (all necessary information is provided) 1 2 3 | Can we add more information to help you? | | |
| | procedure/step | illustration | feature |
| | example | guideline | other |
| | explanation | definition | |
| | | | |
| Technical Accuracy (all provided information is correct) 1 2 3 | Can we be more accurate? | | |
| | text | illustration | |
| | | | |
| | | | |
| Clarity (all provided information is easy to understand) 1 2 3 | How can we make things clearer? | | |
| | | | |
| | | | |
| | | | |
| Other Comments | You can add additional comments on the back of this form. | | |
| | | | |
| | | | |

Your Name _____
 Your Title/Function _____
 Location/Phone _____

Would you like us to contact you regarding your comments?
 No, there is no need to contact me
 Yes, please call me
 Yes, please email me at _____
 Yes, please contact me via _____

Return this form to: Rockwell Automation Technical Communications, 1 Allen-Bradley Dr., Mayfield Hts., OH 44124-9705
 Fax: 440-646-3525 Email: RADocumentComments@ra.rockwell.com

PLEASE FASTEN HERE (DO NOT STAPLE)

Other Comments

PLEASE FOLD HERE

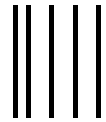

NO POSTAGE
NECESSARY
IF MAILED
IN THE
UNITED STATES

PLEASE REMOVE

BUSINESS REPLY MAIL

FIRST-CLASS MAIL PERMIT NO. 18235 CLEVELAND OH

POSTAGE WILL BE PAID BY THE ADDRESSEE

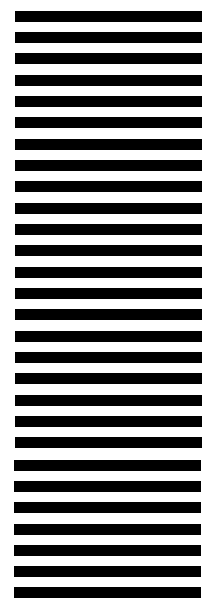

Rockwell Automation Support

Rockwell Automation provides technical information on the web to assist you in using its products. At <http://support.rockwellautomation.com>, you can find technical manuals, a knowledge base of FAQs, technical and application notes, sample code and links to software service packs, and a MySupport feature that you can customize to make the best use of these tools.

For an additional level of technical phone support for installation, configuration and troubleshooting, we offer TechConnect Support programs. For more information, contact your local distributor or Rockwell Automation representative, or visit <http://support.rockwellautomation.com>.

Installation Assistance

If you experience a problem with a hardware module within the first 24 hours of installation, please review the information that's contained in this manual. You can also contact a special Customer Support number for initial help in getting your module up and running:

| | |
|-----------------------|--|
| United States | 1.440.646.3223 Monday – Friday, 8am – 5pm EST |
| Outside United States | Please contact your local Rockwell Automation representative for any technical support issues. |

New Product Satisfaction Return

Rockwell tests all of its products to ensure that they are fully operational when shipped from the manufacturing facility. However, if your product is not functioning and needs to be returned:

| | |
|-----------------------|--|
| United States | Contact your distributor. You must provide a Customer Support case number (see phone number above to obtain one) to your distributor to complete the return process. |
| Outside United States | Please contact your local Rockwell Automation representative for return procedure. |

www.rockwellautomation.com

Corporate Headquarters

Rockwell Automation, 777 East Wisconsin Avenue, Suite 1400, Milwaukee, WI, 53202-5302 USA, Tel: (1) 414.212.5200, Fax: (1) 414.212.5201

Headquarters for Allen-Bradley Products, Rockwell Software Products and Global Manufacturing Solutions

Americas: Rockwell Automation, 1201 South Second Street, Milwaukee, WI 53204-2496 USA, Tel: (1) 414.382.2000, Fax: (1) 414.382.4444

Europe/Middle East/Africa: Rockwell Automation SA/NV, Vorstlaan/Boulevard du Souverain 36, 1170 Brussels, Belgium, Tel: (32) 2 663 0600, Fax: (32) 2 663 0640

Asia Pacific: Rockwell Automation, Level 14, Core F, Cyberport 3, 100 Cyberport Road, Hong Kong, Tel: (852) 2887 4788, Fax: (852) 2508 1846

Headquarters for Dodge and Reliance Electric Products

Americas: Rockwell Automation, 6040 Ponders Court, Greenville, SC 29615-4617 USA, Tel: (1) 864.297.4800, Fax: (1) 864.281.2433

Europe/Middle East/Africa: Rockwell Automation, Herman-Heinrich-Gossen-Strasse 3, 50858 Köln, Germany, Tel: 49 (0) 2234 379410, Fax: 49 (0) 2234 3794164

Asia Pacific: Rockwell Automation, 55 Newton Road, #11-01/02 Revenue House, Singapore 307987, Tel: (65) 6356 9077, Fax: (65) 6356 9011