

# AIR HYDRAULIC CART, AIR-800-D

**\*\*Any additions, deletions or omissions must be corrected on this drawing, as this drawing will be considered all inclusive.\*\***

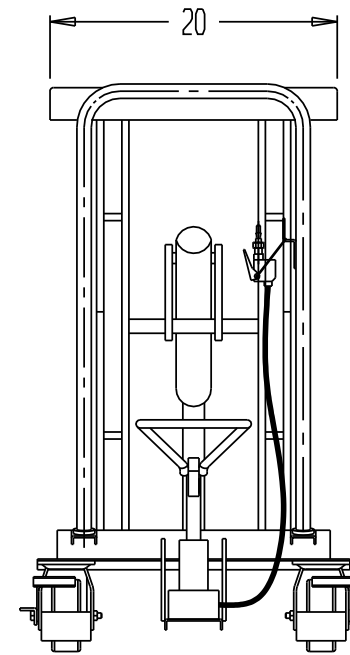
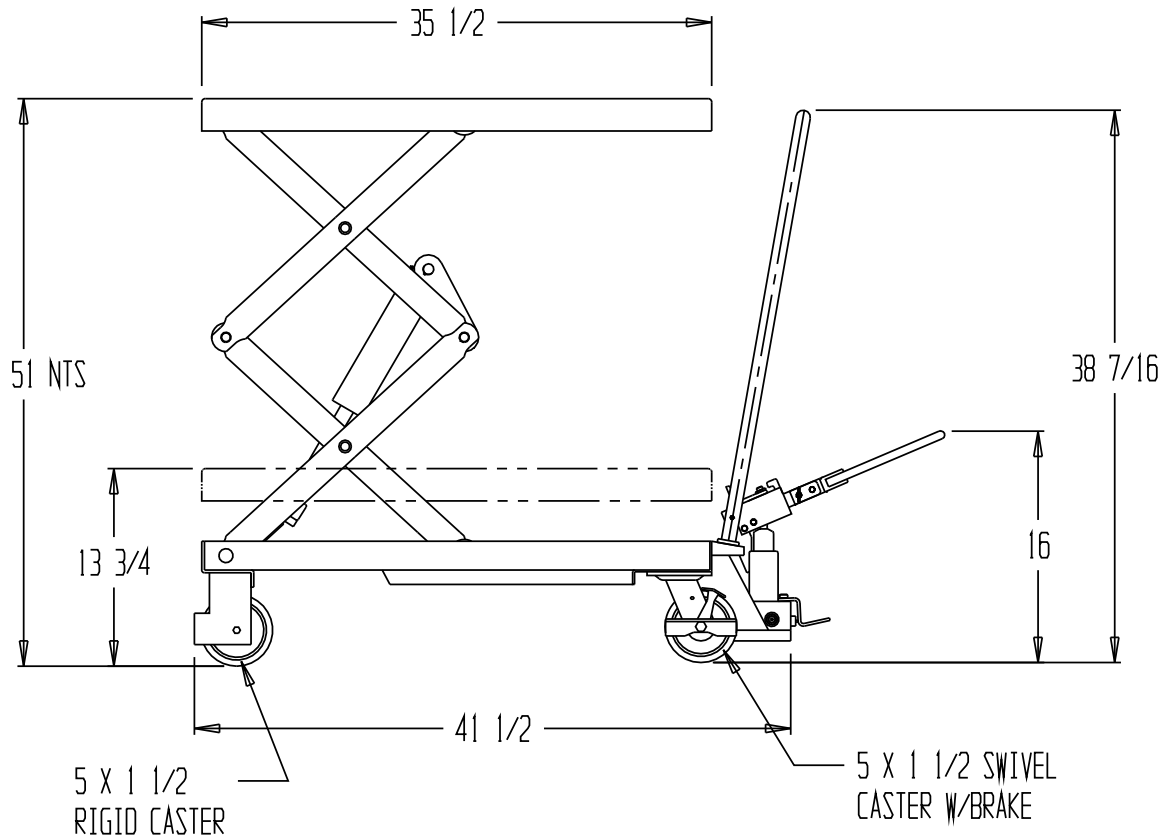

LEAD TIME WILL START UPON RECEIPT OF SIGNED APPROVAL DRAWING

## STANDARD FEATURES

- MODEL NUMBER: AIR-800-D
- CAPACITY: 800 LBS.
- PLATFORM WIDTH: 20"
- PLATFORM LENGTH: 35 1/2"
- PLATFORM RAISED HEIGHT: 51"
- PLATFORM LOWERED HEIGHT: 13 3/4"
- OPERATION: TWO SPEED FOOT PUMP  
OR HAND HELD RECIPROCATING AIR/OIL

## SPECIAL FEATURES

NONE

**\*\*SPECIAL UNITS ARE NON-RETURNABLE  
\*AVAILABLE AT ADDITIONAL COSTS**

**\*\*\* ALL GRAPHICS PROVIDED ARE FOR REFERENCE ONLY. IF CERTAIN DIMENSIONS ARE CRITICAL PLEASE VERIFY THOSE DIMENSIONS WITH YOUR SALESPERSON. \*\*\***

## APPROVAL

I, the undersigned, hereby approve this print  
 As drawn       As marked

This includes my approval of design & dimensions.

Signed: \_\_\_\_\_

Date: \_\_\_\_\_

DISTRIBUTOR'S NAME:		P.O.#: -
<b>VESTIL MANUFACTURING</b>		W.O.#: -
DRAWN BY: SR	DATE: 1-22-09	SALES: -
REFERENCE:		DRWG./FILE NAME:
-	SCALE: 1:14	AIR-800-D