

REVISIONS				
ECR	REV.	DESCRIPTION	DATE	INITIAL
1846	A	NOTE ADDED TO HARDWARE	10/30/2013	JCH

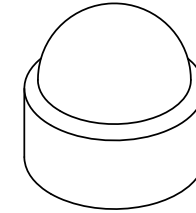

ACTUAL SIZE

NOTE:



1/2" ϕ ANCHOR BOLT
3/4" HEX

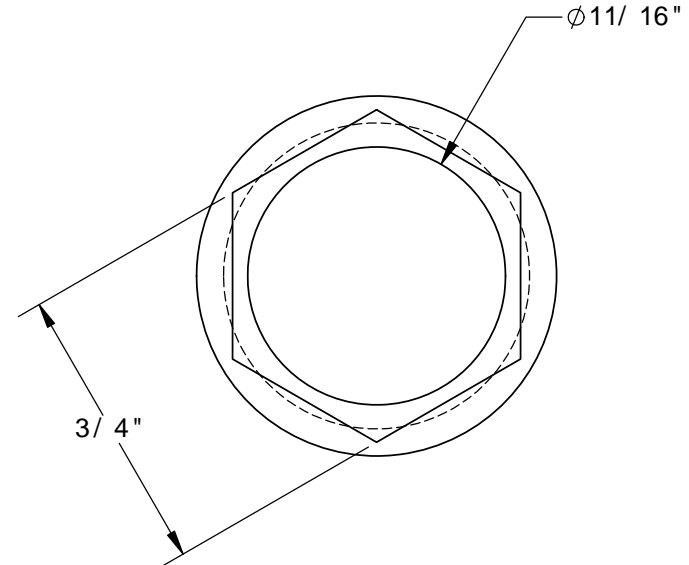
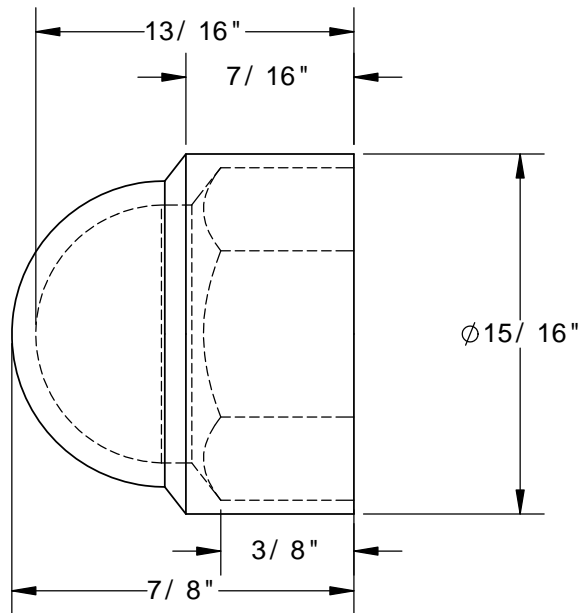

PROPRIETARY AND CONFIDENTIAL
THE INFORMATION CONTAINED IN THIS DRAWING IS THE SOLE PROPERTY OF VESTIL MANUFACTURING CO. ANY REPRODUCTION IN PART OR AS A WHOLE WITHOUT THE WRITTEN PERMISSION OF VESTIL MANUFACTURING CO. IS PROHIBITED.

UNLESS OTHERWISE SPECIFIED:

REMOVE ALL BURRS AND SHARP EDGES

DIMENSIONS ARE IN INCHES

CONCENTRIC	.006 TIR	.060 TIR
ANGLES	$\pm 0^{\circ} 30'$	$\pm 1^{\circ} 0'$
DECIMALS	x.xxx $\pm .005$ x.xx $\pm .010$	
FRACTIONS	x.x $\pm .025$	$\pm .015$
TOLERANCES	MACHINE	WELDMENT

COMMENTS:

DO NOT SCALE DRAWING

Vestil Manufacturing Co.

DESCRIPTION:
FINAL ASSEMBLY W/OUT SHIPPING

PRODUCT MODEL NO: BC-BK-12-PK

DRAWN BY: K.YEAKLE	DATE: 06/28/12	SCALE: 2:1	SIZE A
-----------------------	-------------------	------------	------------------

MAT'L: PLASTIC, BLACK

SHEET 1 OF 1	DWG. NO. 99-024-022	REV A
--------------	-------------------------------	----------