

SELF STORING BOLLARD - BOL-SSTOR-42-4.5

APPROX WEIGHT: 108.84 lbs.
 DOES NOT INCLUDE WEIGHT OF POWER OR PACKAGING!!!

*** ANY ADDITIONS, DELETIONS, OR OMISSIONS MUST BE CORRECTED ON THIS DRAWING AS THIS DRAWING WILL BE CONSIDERED ALL INCLUSIVE ***

ALL GRAPHICS PROVIDED ARE FOR REFERENCE ONLY. IF CERTAIN DIMENSIONS ARE CRITICAL PLEASE VERIFY THOSE DIMENSIONS WITH YOUR SALESPERSON

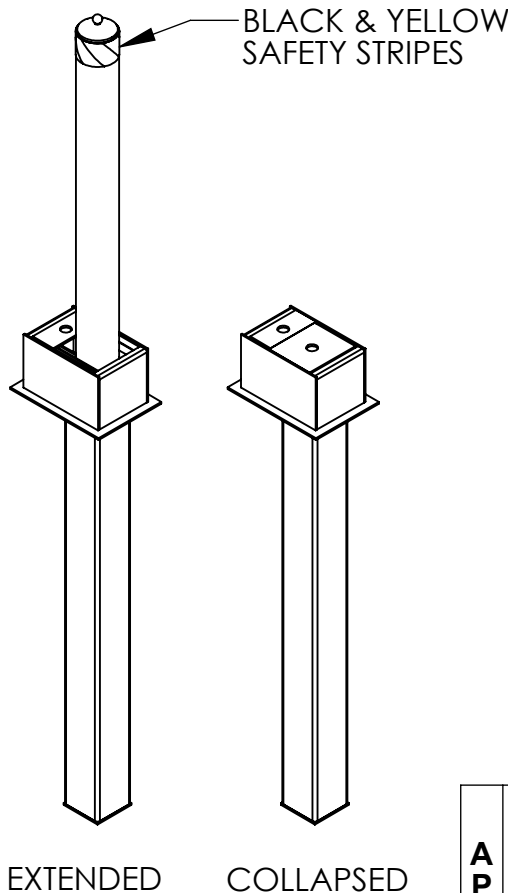
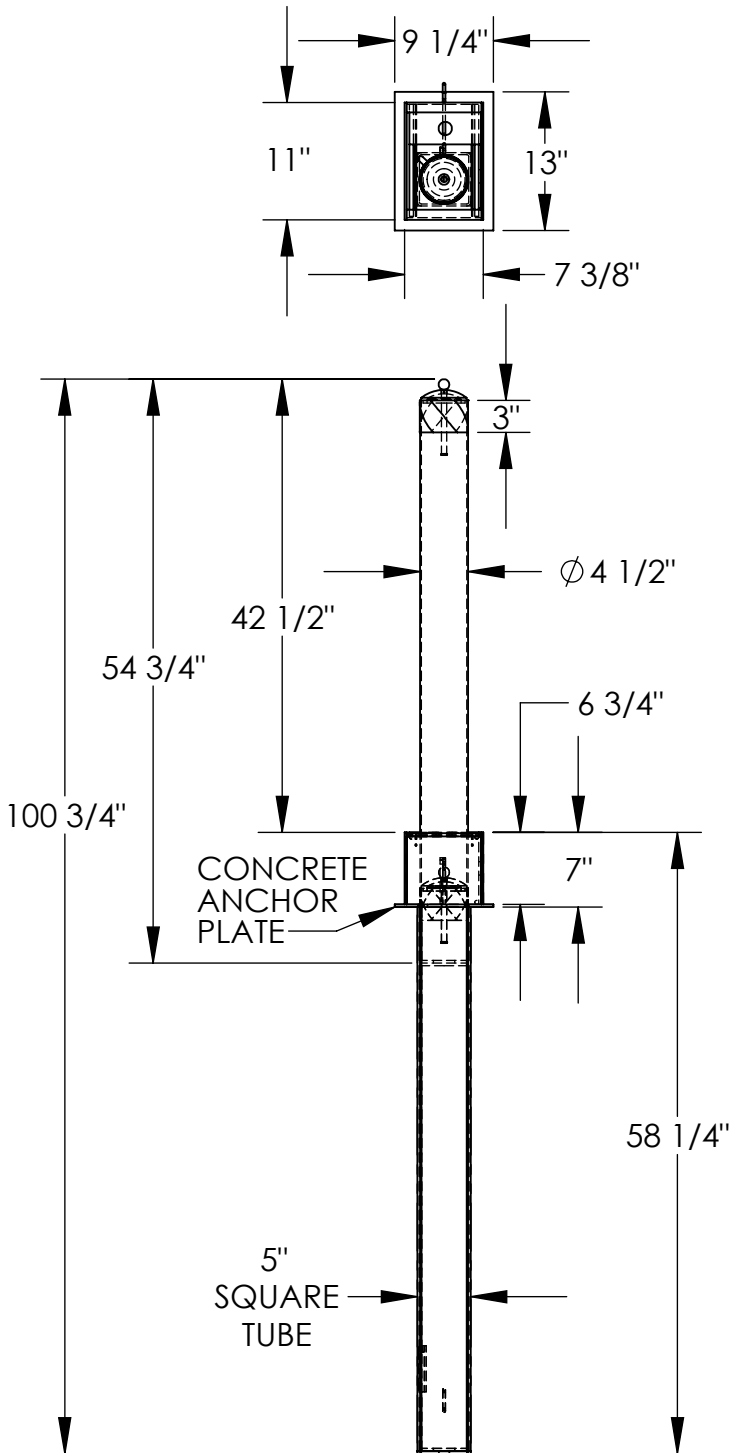

STANDARD FEATURES

- MODEL NUMBER: BOL-SSTOR-42-4.5
- OVERALL HEIGHT: 100 3/4"
- USABLE (ABOVE GROUND) HEIGHT: 42 1/2"
- BOLLARD DIAMETER: 4 1/2"
- BASE TO BE CEMENTED BELOW GRADE
- HANDLE IN TOP CAP
- TOUGH BAKED IN POWDERCOATED YELLOW FINISH
- BLACK & YELLOW SAFETY STRIPES
- ALL STEEL CONSTRUCTION (ASTM A-36 MIN.) WITH WELDING TO MEET AWS
- WARNING: CHECK APPLICABLE STATE & LOCAL LAWS FOR YOUR AREA

SPECIAL FEATURES

NONE

DIMENSION TOLERANCE ± 1/4"

I, THE UNDERSIGNED, AGREE THAT THE PRODUCT AS REPRESENTED SATISFIES DESIGN AND DIMENSION REQUIREMENTS. I ALSO ACKNOWLEDGE MY DUTY TO CONFIRM PRODUCT AND INSTALLATION COMPLIANCE WITH ALL APPLICABLE FEDERAL, STATE AND LOCAL REGULATIONS AND STANDARDS.

ANY MODIFIED UNITS ARE NON-RETURNABLE

As drawn As marked

Signed: _____ Date: _____

Printed Name: _____

LEAD TIME WILL START UPON RECEIPT OF SIGNED APPROVAL DRAWING

DISTRIBUTOR'S NAME:		P.O.#
VESTIL MANUFACTURING		X
DRAWN BY: KW		W.O.#
DATE: 6/25/2007		X
REFERENCE: X	SCALE: 1:18	SALES: X
QUOTED LEAD TIME: X	QUOTE #	FILE NAME:
	X	23-007-229

FOR INTERNAL USE ONLY PROJECT SIGN OFF	
SALES	
ENG.	
FAB.	
POWER	