

# MANUAL CAROUSEL CA-HBK

## CAROUSEL OPTIONS:

* BRAKES / DETENTS		
HAND DETENT	FOOT DETENT	HAND BRAKE
* TOP PLATE		
XX" ROUND	XX" x XX" SQUARE	
CHECKER PLATE	SMOOTH PLATE	
* ELEVATED BASE		
	12" HT.	24" HT.

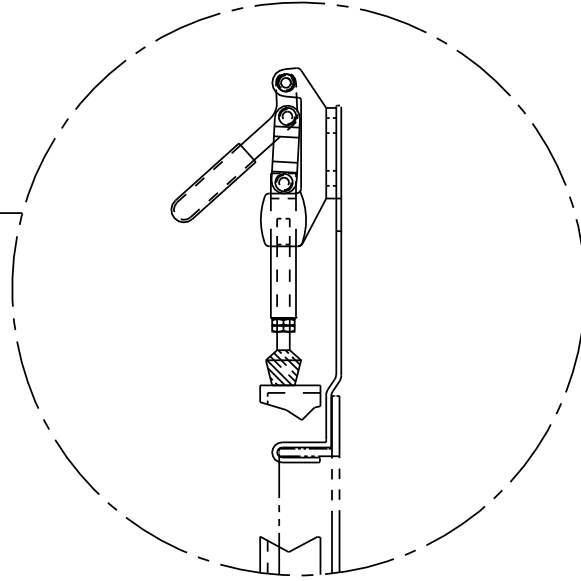
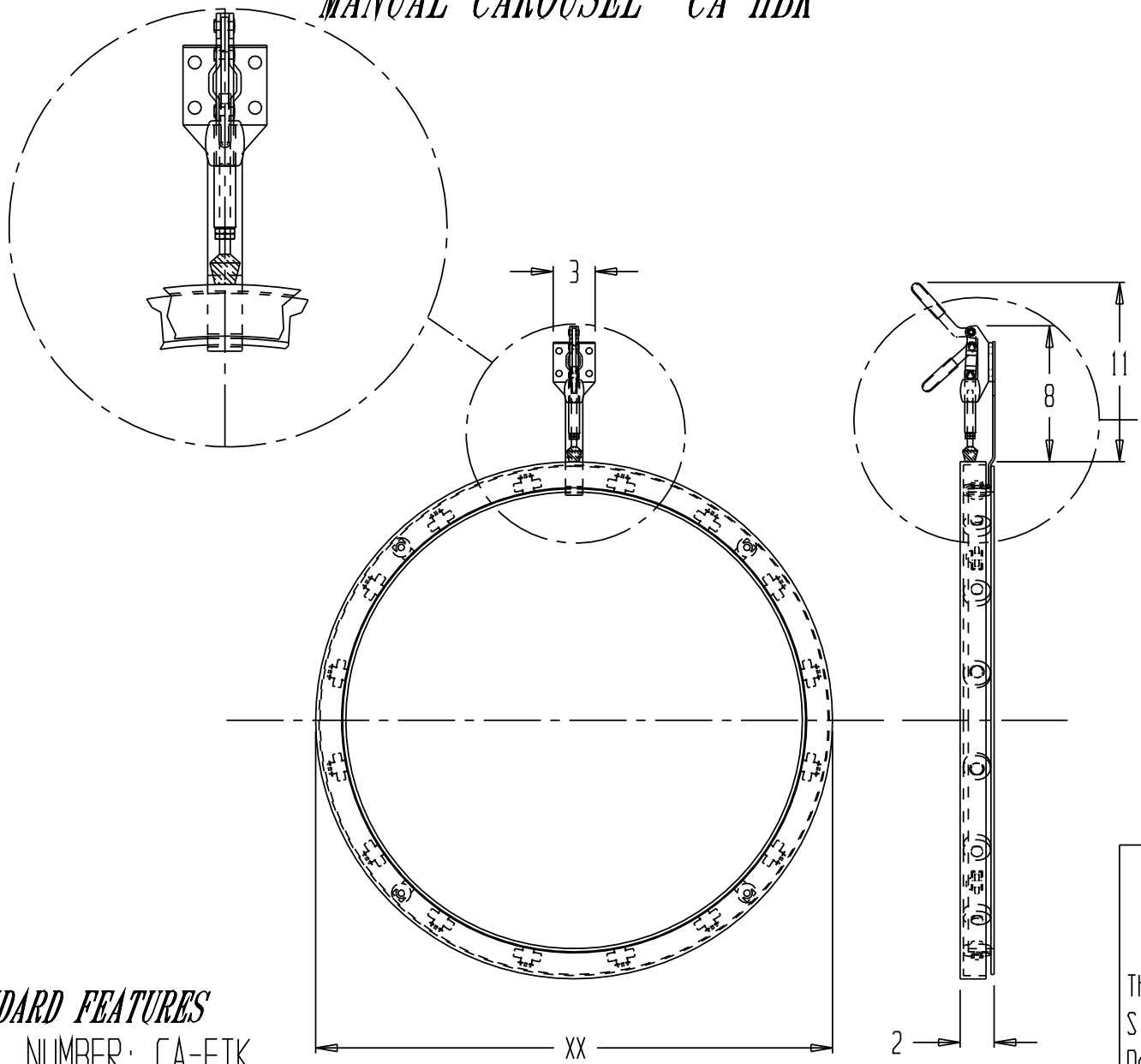

NOTE: PINS AND ROLLER BEARINGS REMOVED FOR CLARITY.

**STANDARD FEATURES**  
MODEL NUMBER: CA-FTK

LEVEL HEIGHT: 2"

PRODUCTION WILL START UPON RECEIPT OF SIGNED APPROVAL DRAWING

\*\*SPECIAL UNITS ARE NON-RETURNABLE  
\*AVAILABLE AT ADDITIONAL COSTS

**APPROVAL**

I, the undersigned, hereby approve this print  
 As drawn       As marked  
 This includes my approval of design & dimensions.  
 Signed: \_\_\_\_\_  
 Date: \_\_\_\_\_

DISTRIBUTOR'S NAME:		P.O.#: _
<b>T &amp; S EQUIPMENT</b>		W.O.#: _
DRAWN BY: _	DATE: _	SALES: _
REFERENCE:		DRWG./FILE NAME:
-		scale: NTS 20-007-034