

MANUAL TRASH COMPACTOR - MTC-30

APPROX WEIGHT: 157.78 lbs.
DOES NOT INCLUDE WEIGHT OF POWER OR PACKAGING!!!

*** ANY ADDITIONS, DELETIONS, OR OMISSIONS MUST BE CORRECTED ON THIS DRAWING AS THIS DRAWING WILL BE CONSIDERED ALL INCLUSIVE ***

ALL GRAPHICS PROVIDED ARE FOR REFERENCE ONLY. IF CERTAIN DIMENSIONS ARE CRITICAL PLEASE VERIFY THOSE DIMENSIONS WITH YOUR SALESPERSON

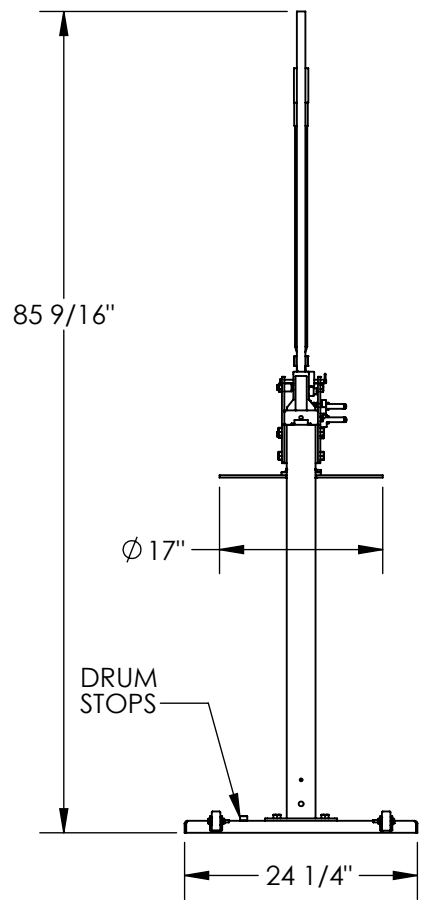

STANDARD FEATURES

MODEL NUMBER: MTC-30
OVERALL WIDTH: 32 1/16"
USABLE WIDTH: 25 3/8"
OVERALL LENGTH: 24 1/4"
USABLE LENGTH: 24 1/4"
OVERALL HEIGHT: 85 9/16"
SERVICE RANGE: 1 1/4" TO 35 3/4"
COMPACTOR HEAD: 17"
7,000 LBS OF COMPACTING FORCE
WHEELS: RUBBER - 2"
TOUGH BAKED IN POWDER COATED BLUE FINISH
DRUM USED: 30 GALLON

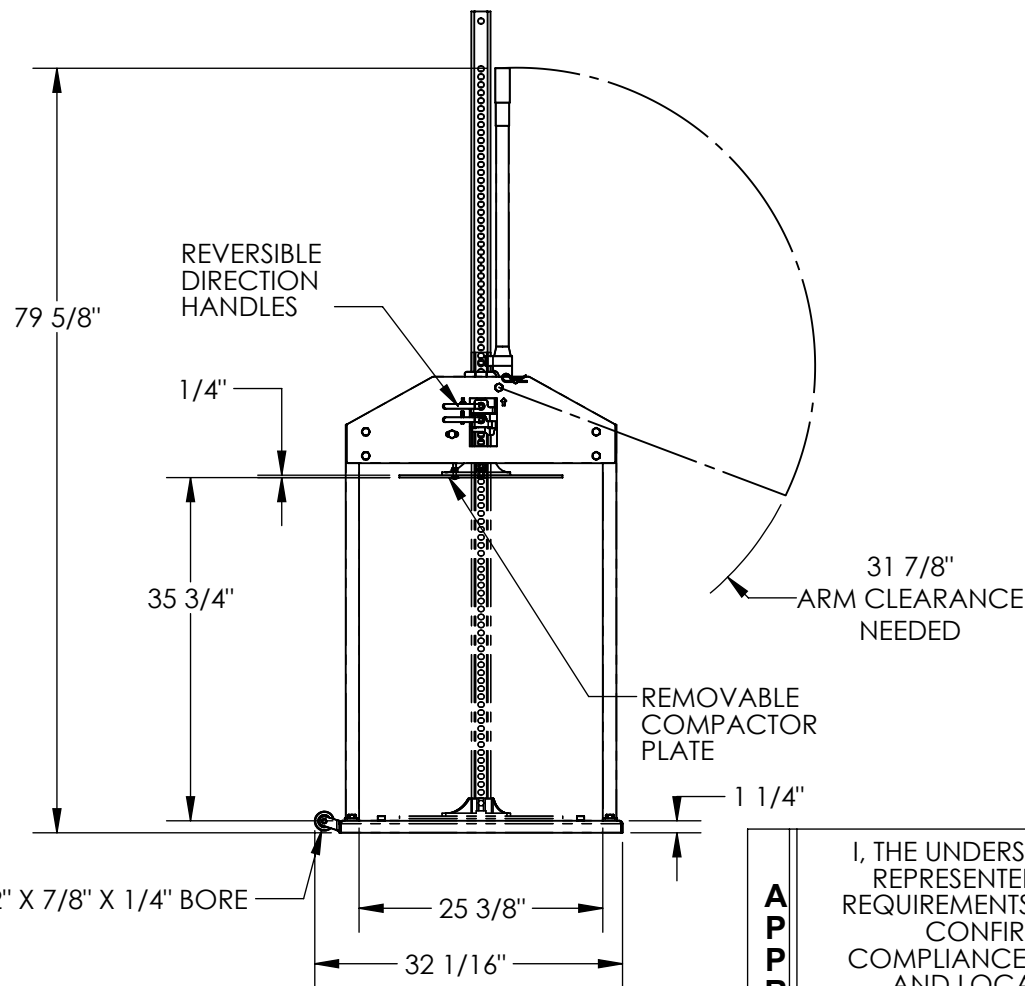

SPECIAL FEATURES

NONE

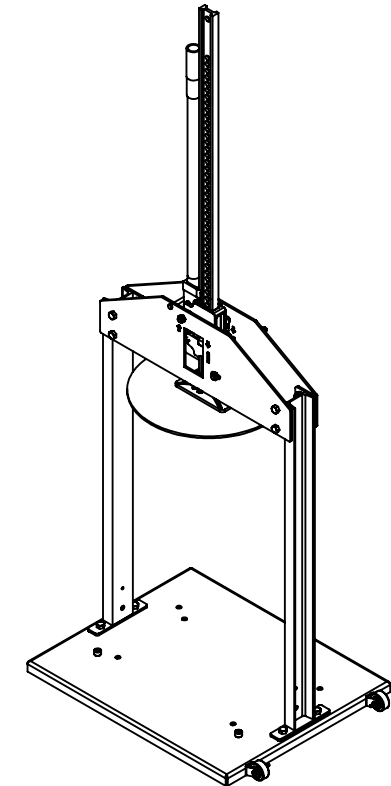

DIMENSION TOLERANCE ± 1/4"

APPROVAL

I, THE UNDERSIGNED, AGREE THAT THE PRODUCT AS REPRESENTED SATISFIES DESIGN AND DIMENSION REQUIREMENTS. I ALSO ACKNOWLEDGE MY DUTY TO CONFIRM PRODUCT AND INSTALLATION COMPLIANCE WITH ALL APPLICABLE FEDERAL, STATE AND LOCAL REGULATIONS AND STANDARDS.
UNITS REQUIRING APPROVAL DRAWINGS OR MODIFIED ARE NON-RETURNABLE

[] As drawn [] As marked

Signed: _____ Date: _____

Printed Name: _____

LEAD TIME WILL START UPON RECEIPT OF SIGNED APPROVAL DRAWING

DISTRIBUTOR'S NAME:		P.O.#
VESTIL MANUFACTURING		X
DRAWN BY: WS		W.O.#
DATE: 02/03/2009		X
REFERENCE: X	SCALE: 1:20	SALES: X
QUOTED LEAD TIME: X	QUOTE #	FILE NAME:
	X	22-007-008