

SEMI LIVE SKID LEGS - VHPT-SL-LEG-24

APPROX WEIGHT: 9.99 lbs.
DOES NOT INCLUDE WEIGHT OF POWER OR PACKAGING!!!

*** ANY ADDITIONS, DELETIONS, OR OMISSIONS MUST BE CORRECTED ON THIS DRAWING AS THIS DRAWING WILL BE CONSIDERED ALL INCLUSIVE ***

ALL GRAPHICS PROVIDED ARE FOR REFERENCE ONLY. IF CERTAIN DIMENSIONS ARE CRITICAL PLEASE VERIFY THOSE DIMENSIONS WITH YOUR SALESPERSON

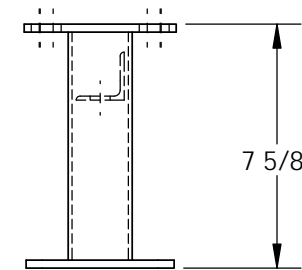
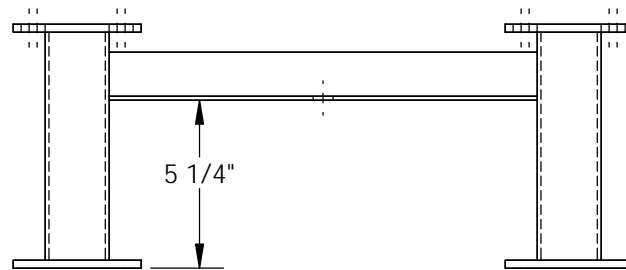
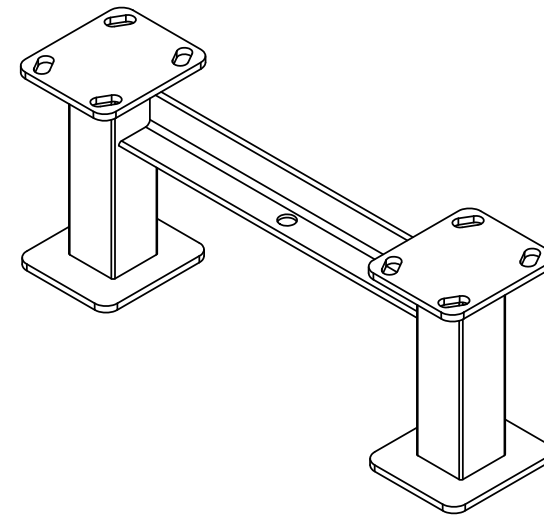
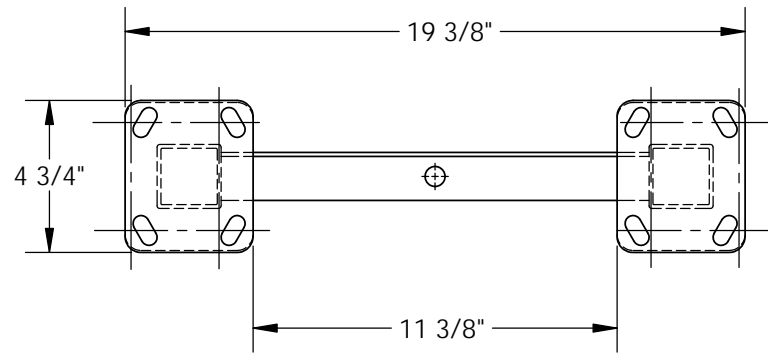

DIMENSION TOLERANCE $\pm 1/4$ "

STANDARD FEATURES

- MODEL NUMBER IS VHPT-SL-LEG-24
- OVERALL WIDTH IS 19 3/8"
- OVERALL DEPTH IS 4 3/4"
- OVERALL HEIGHT IS 7 5/8"
- FOR USE ON VHPT HARDWOOD PLATFORM TRUCKS
- USED IN CONJUNCTION WITH VHPT-JACK, SEMI-LIVE LEVER JACK
- POWDERCOAT FINISH
- UNIT ATTACHES TO EXISTING CASTER MOUNTING HOLES

SPECIAL FEATURES

NONE

APPROVAL	I, THE UNDERSIGNED, AGREE THAT THE PRODUCT AS REPRESENTED SATISFIES DESIGN AND DIMENSION REQUIREMENTS. I ALSO ACKNOWLEDGE MY DUTY TO CONFIRM PRODUCT AND INSTALLATION COMPLIANCE WITH ALL APPLICABLE FEDERAL, STATE AND LOCAL REGULATIONS AND STANDARDS.	
	ALL SPECIAL UNITS ARE NON-RETURNABLE [] As drawn [] As marked	
Signed: _____		Date: _____
LEAD TIME WILL START UPON RECEIPT OF SIGNED APPROVAL DRAWING		

FOR INTERNAL USE ONLY PROJECT SIGN OFF	
SALES	
ENG.	
FAB.	
POWER	

DISTRIBUTOR'S NAME:		P.O.#
VESTIL MANUFACTURING		X
DRAWN BY:	DATE:	W.O.#
TJM	12/07/11	X
REFERENCE:	SCALE:	SALES:
X	1:6	X
QUOTED LEAD TIME:	QUOTE #	FILE NAME:
X	X	33-007-233