

To Protect Your Warranty, Use Only ENERPAC Hydraulic Oil.  
 Enerpac recommends that all kit components be installed to insure optimum performance of the repaired unit.

**NOTE:** Grill, Item 7, requires slight modification when installed to allow clearance for valves and air supply tube.  
 For roll bar model see page 7.

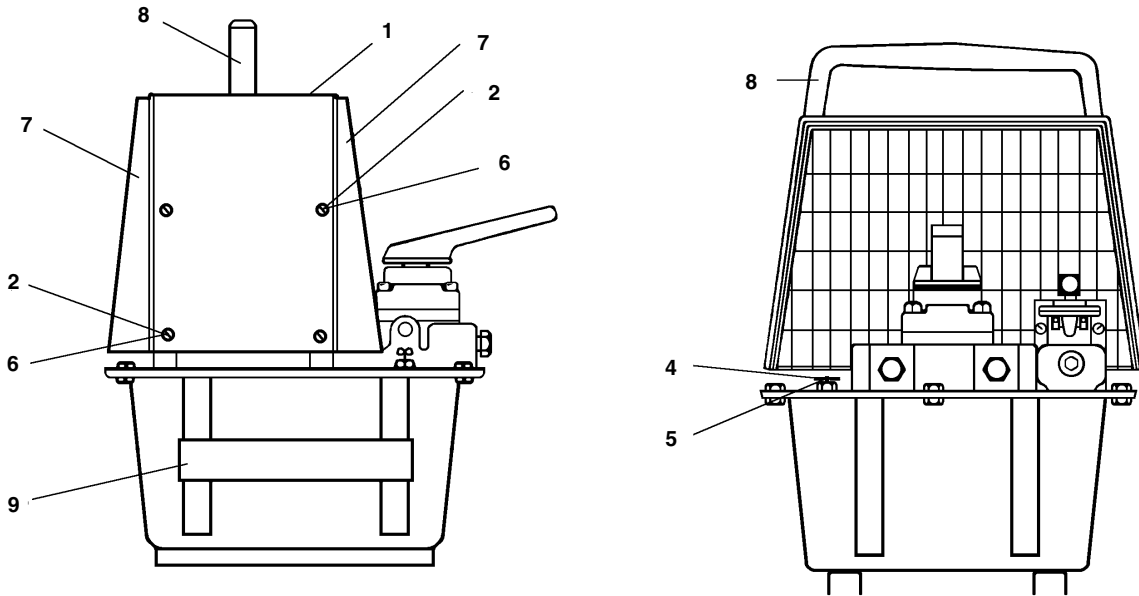

Figure 1, Enerpac Twin-air Pump

Repair Parts List for Figure 1

Item	Part Number	Qty.	Description
1	Y262950-114	1	Cover
2	F866028	8	Button Head Screw #10-24 x 1/2" Lg.
4	CA561024	4	Drain Cock
5	CN721026	1	Filler Plug Decal
6	M783055	8	Speed Nut
7	Y259024	2	Grill
8	Y175950W	1	Handle Assembly
9	G424026	2	Decal

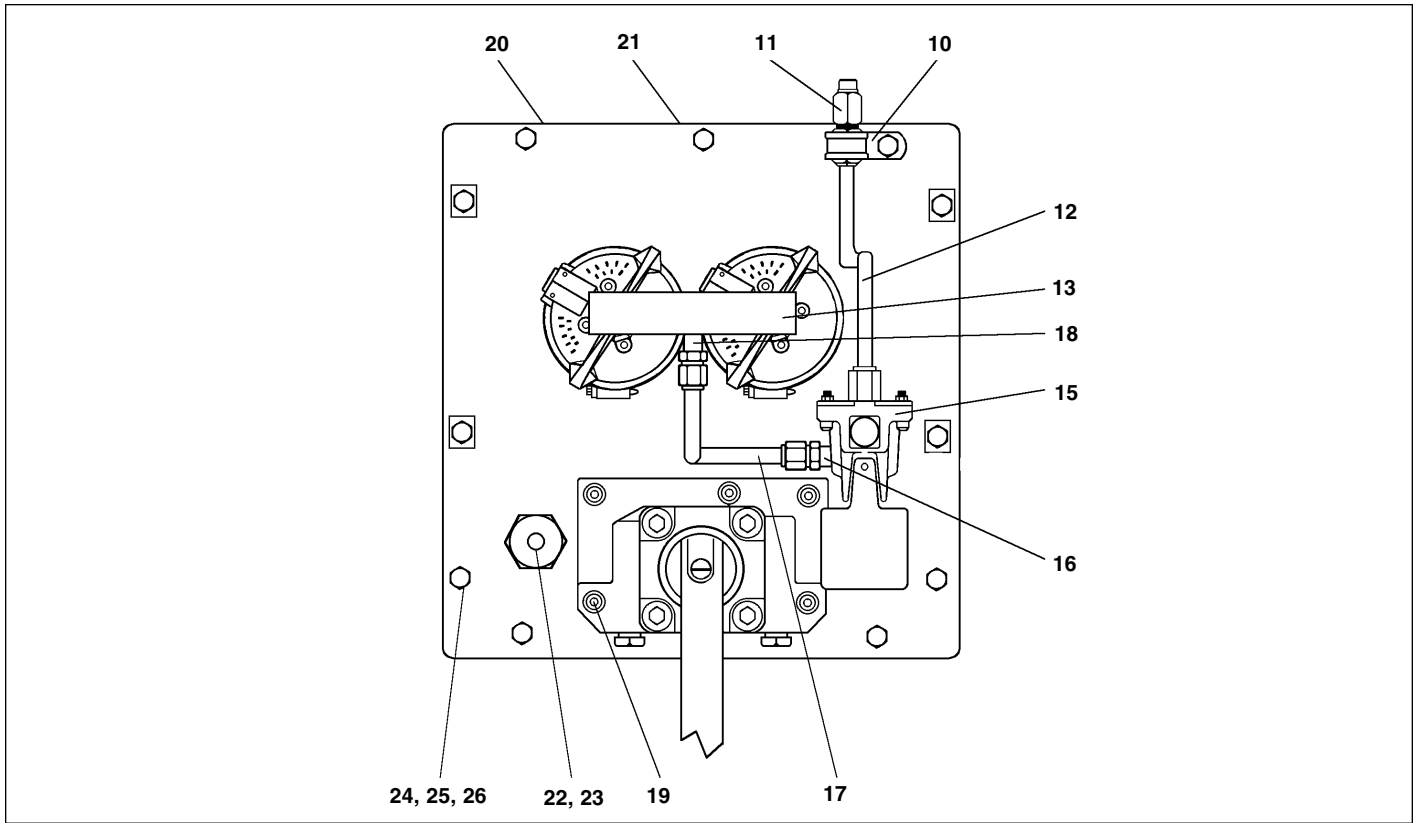

Figure 2, Top View of Pump

Repair Parts List for Figure 2

Item	Part Number	Qty.	Description	Item	Part Number	Qty.	Description
10	CA203017	1	Clamp	20	CM410098	1	Cover
11	CA198096	1	Female Connector	21	★ Y252167	1	Gasket
12	CA197268	1	Tube Assembly	22	CA563024SR	1	Filler Plug
13	CJ315900SR	1	Manifold Assembly	23	★ B1019503	1	O-ring
15	CL144950W	1	Air Valve Assembly	24	B1001120	12	Hex Nut 1/4-20 UNC
16	CA945096	1	Male Connector	25	B1005046	12	Hex Head Cap Screw 1/4-20 x 3/4 Lg.
17	CJ320900	1	Tube Assembly	26	B1015066	12	Lock Washer (medium series) 1/4 bolt size
18	CJ319096	1	Male Connector				
19	See A below	—	Socket Head Cap Screw				

★ Indicates items included in Repair Kit PAM-1042K3.

	1021 Models	Qty.	1022 Models	Qty.	1041 Models	Qty.	1042 Models	Qty.
A	5/16-18 UNC x 1.00 Lg.	6	5/16-18 UNC x 1.00 Lg.	6	5/16-18 UNC x 1.00 Lg.	3	5/16-18 UNC x 1.00 Lg.	3

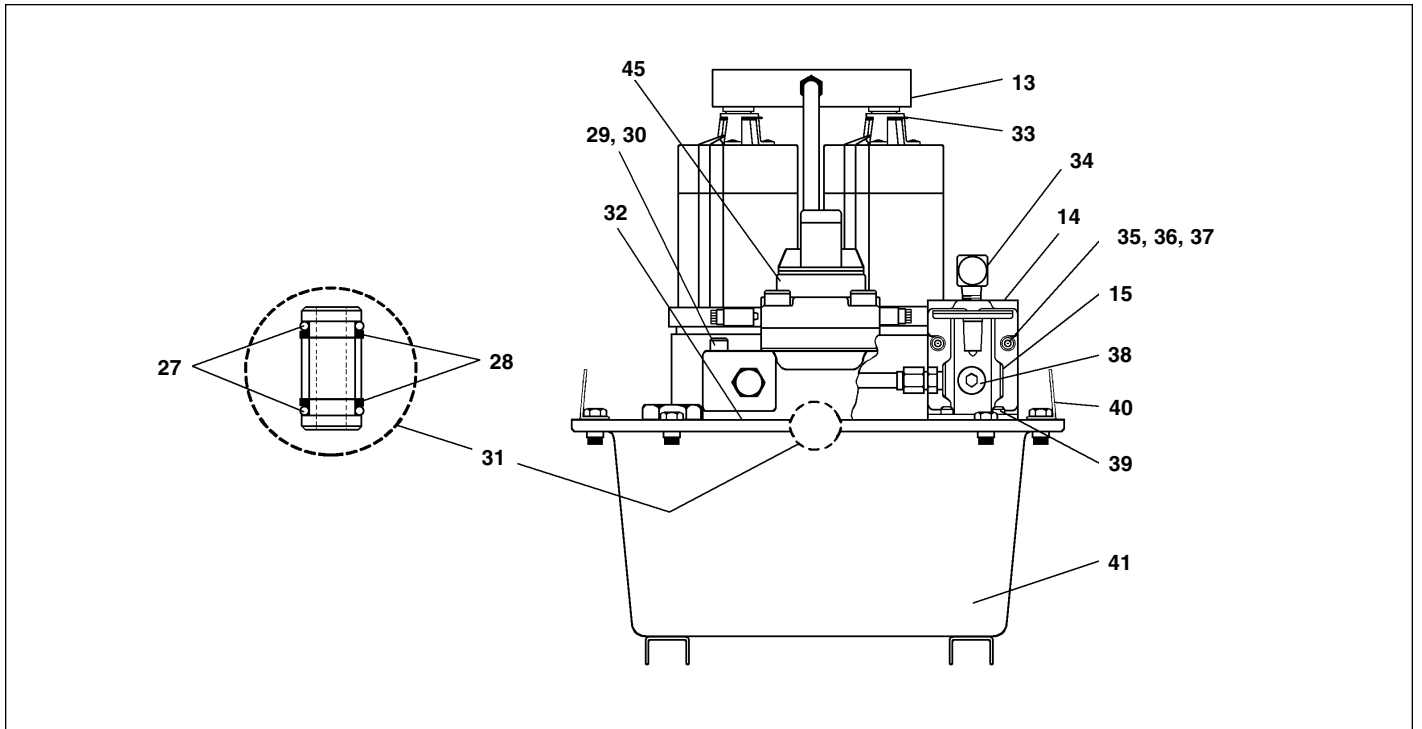

Figure 3, Grill and Cover Removed

**Repair Parts List for Figure 3**

Item	Part Number	Qty.	Description	Item	Part Number	Qty.	Description
13	CJ315900SR	1	Manifold Assembly	37	B1326028	2	Socket Head Cap Screw No.10-32 UNF x 3/4 Lg
14	CA186111	1	Valve Bracket	38	A1009245	1	Pipe Plug
15	CL144950W	1	Air Valve Assembly	39	B1322028	2	Socket Head Cap Screw No.10-32 UNF x 1/2 Lg
27	★ B1007503	2	O-ring	40	CL397111	4	Bracket
28	★ B1012564	2	Back-up Washer	41	See D below	—	Reservoir
29	See B below	—	Socket Head Cap Screw	42	B841026	1	Caution Decal (not shown)
30	★ C846037	6	Gasket	43	G425026	2	Decal (not shown)
31	CN529950K	1	Connector (Includes 27, 28, 32)	44	CB563026	1	Decal (not shown)
32	F786167	1	Gasket	45	Refer to Valve Part Sheet		Valve
33	PP179017	2	Retaining Ring				
34	CA200096	1	Male Elbow				
35	B1018121	2	Nut No.10-32 UNF				
36	B1084108	2	Standard Plain Washer and No.10 Screw				

★ Indicates items included in Repair Kit PAM-1042K3.

	1021 Models	Qty.	1022 Models	Qty.	1041 Models	Qty.	1042 Models	Qty.
B	None required	0	None required	0	5/16-18 UNC x 2.00 Lg.	2	5/16-18 UNC x 2.00 Lg.	2
C	VM-2	1	VM-2	1	VM-4	1	VM-4	1
D	CB523025	1	CB519025	1	CB523025	1	CB519025	1

NOTE: When installing pumps, position air pump assembly, Item 46, before positioning air pump assembly, Item 47.

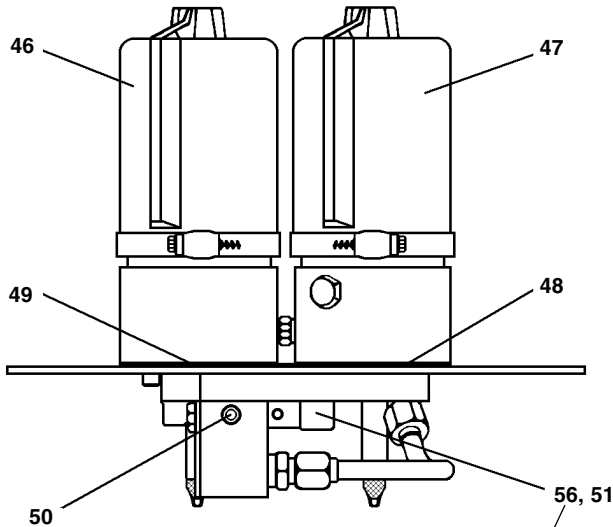

Adjust Relief Valve, Item 56, to 10,300-10,800 psi.

Figure 4, Pump Assembly

NOTE: Torque hex head cap screw, Item 60, to 12-15 ft. lbs.

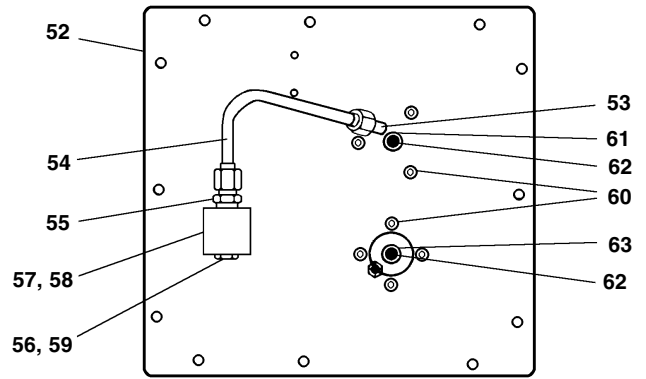

Figure 5, Cover Sub-assembly

Repair Parts List for Figures 4 and 5

Item	Part Number	Qty.	Description	Item	Part Number	Qty.	Description
46	DA5860900SR	1	Air-hydraulic Pump Assembly	56	★ B159167	2	Copper Gasket
47	DA5861900SR	1	Air-hydraulic Pump Assembly	57	Y927038	1	Adaptor Block
48	★ Y253167	1	Gasket	58	Y971028	4	Flat Head Screw 1/4-28 UNF x 5/8 Lg.
49	★ Y268167	1	Gasket	59	AJ100061	1	Plug
50	A1007245	1	Pipe Plug	60	B1006028	7	Hex Head Cap Screw 1/4-28 UNF x 5/8 Lg.
51	P181190W	1	Relief Valve (incl. Item 56)	61	See A below	—	Filter Pipe
52	CM410098	1	Cover	62	P30718	2	Screen
53	Y543291	1	45° Male Elbow	63	See "B" below		
54	CB29268	1	Tube Assembly				
55	CA945096	1	Male Connector				

★ Indicates items included in Repair Kit PAM-1042K3.

	1021 Models	Qty.	1022 Models	Qty.	1041 Models	Qty.	1042 Models	Qty.
A	Y542018	1	Y625018	1	Y542018	1	Y625018	1
B	CJ331018	1	CJ338018	1	CJ338018	1	CJ338018	1

**Repair Notes for Figures 6 and 7:**

Torque connector (Item 82) to 30 ft. lbs.

Repair Kit PAM-1042K3 includes parts used to service hydraulic cylinder assembly (Item 66).

Insert ball guide (Item 71) with outside chamfer facing the ball.

Torque o-ring and pump body (Items 75 and 79) to 25 ft. lbs.

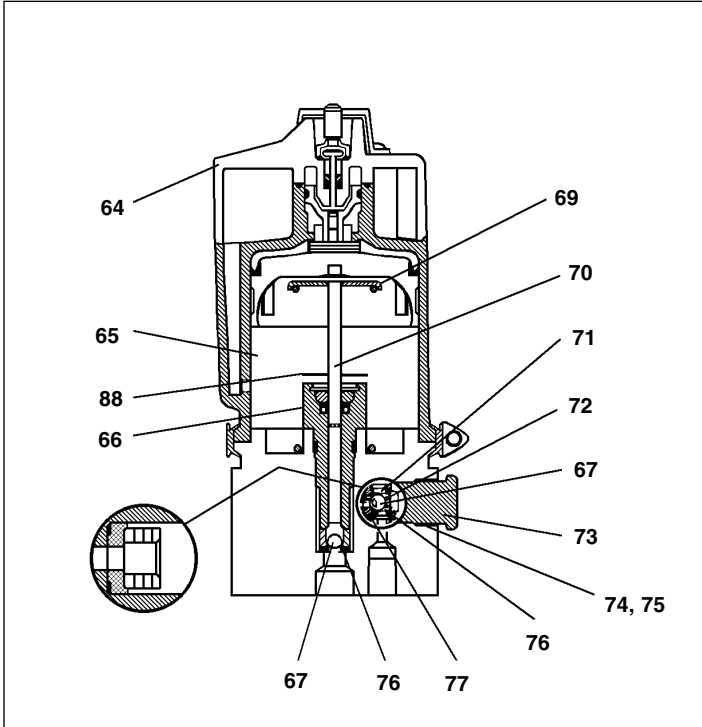

**Figure 6**

**Air-Hydraulic Pump Assembly DA5861900SR**

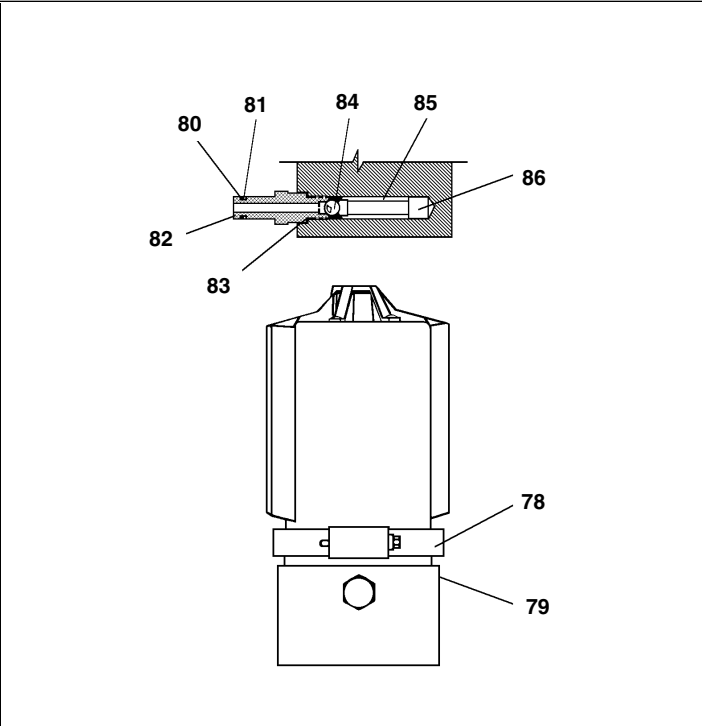

**Figure 7**

**Repair Parts List for Figures 6 and 7**

Item	Part Number	Qty.	Description	Item	Part Number	Qty.	Description
64	CB336900SR	1	Air Motor Assembly	77	★ † P20037	2	Gasket
65	CH210110	1	Spring	78	CB219044W	1	V-retainer Coupling
66	CH203950SR	1	Hydraulic Cylinder Assembly	79	CB352190	1	Pump Body
67	★ † B1006016	2	7/32" Ball	80	★ † B1007505	1	O-ring
69	A8009108	1	Washer	81	★ † B1012565	1	Back-up Washer
70	CB180040	1	Plunger	82	CJ53096	1	Connector
71	CH411013	1	Ball Guide	83	★ † Y602167	1	Gasket
72	★ † CA978110	1	Spring	84	★ † B1009016	1	5/16" Ball
73	CB353006	1	Plug	85	★ † Y267110	1	Spring
74	★ † B1014565	1	Back-up Washer	86	CF236018	1	Guide
75	★ † B1220503	1	O-ring	88	DA7095108	1	Rubber Washer
76	★ † CH814290	2	Ball Seat				

★ Indicates items included in Repair Kit PAM-1042K3.

† Indicates items included in Repair Kit CB370900K.

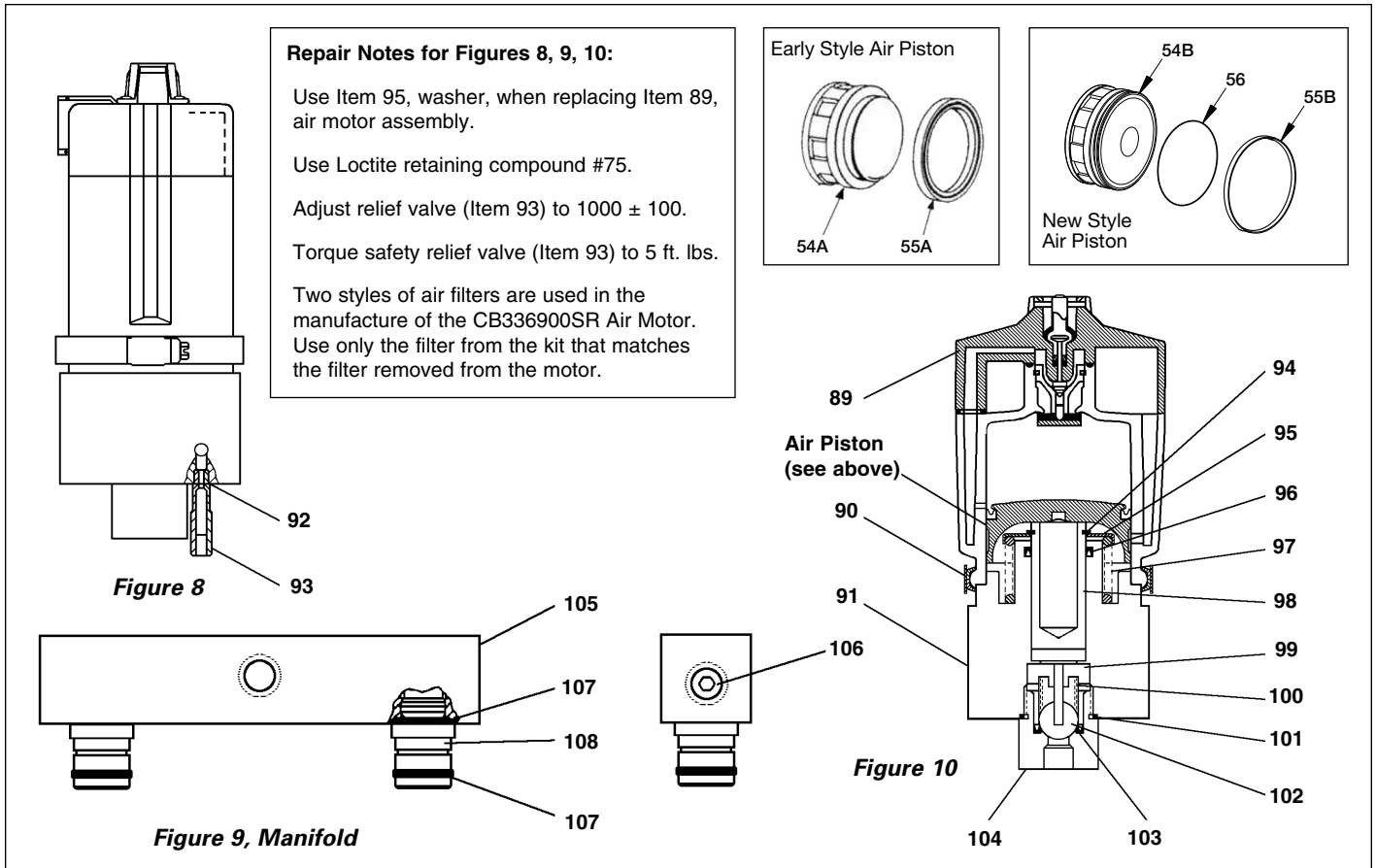

**Air-hydraulic Pump Assembly DA5860900SR**

**IMPORTANT:**

Early style air piston assembly (items 54A and 55A) is no longer available.

If replacement is required, new style air piston assembly (items 54B, 55B and 56) must be used. Order Repair Kit CK354950SR.

**To replace an early style air piston assembly:**

- Remove early style air piston (item 54A) and U-Cup seal (item 55A) from air motor. These parts will not be reused and can be discarded.
- Install O-Ring (item 56) and Glyd Ring (item 55B) into groove on new style air piston (item 54B). Apply grease to Glyd Ring (item 55B).
- Install new style air piston assembly (items 54B, 55B and 56) inside air motor.

**Repair Parts List for Figures 8, 9 and 10**

Item	Part Number	Qty.	Description	Item	Part Number	Qty.	Description
54B	◆	1	Air Piston (new style)	98	CF235040	1	Plunger
55B	◆	1	Glyd Ring	99	★▲ A8416900	1	Spring Guide Assembly
56	◆	1	O-ring	100	★▲ A8078110	1	Spring
89	CB336900SR	1	Air Motor Assembly	101	★▲ B1123903	1	O-ring
90	CB219044	1	V-retainer Coupling	102	★▲ B1021016	1	0.688" Ball
91	CB351190	1	Pump Body	103	★▲ A8026476	1	Oil Seal
92	★▲ S3037	1	Gasket	104	CJ73290	1	Insert Seat
93	CH945900W	1	Safety Relief Valve	105	CJ325038	1	Manifold
94	★▲ A8063049	1	Retaining Ring	106	A1015245	1	Pipe Plug
95	DC256108	1	Washer	107	★ B1220503	4	O-ring
96	★▲ Y741041	1	U-Cup	108	CJ324096	2	Connector
97	A8079110	1	Spring				

★ Indicates items included in Repair Kit PAM-1042K3.

◆ Indicates items included in Repair Kit CK354950SR.

▲ Indicates items included in Repair Kit CB363900K.

NOTE: Changes have been made in the design of the shuttle piston, end cover, and air cylinder, which improve air motor performance. The new parts will not work when used with existing old-style parts. If one of these parts needs replacement, a completely new air motor, CB336900SR, must be used.

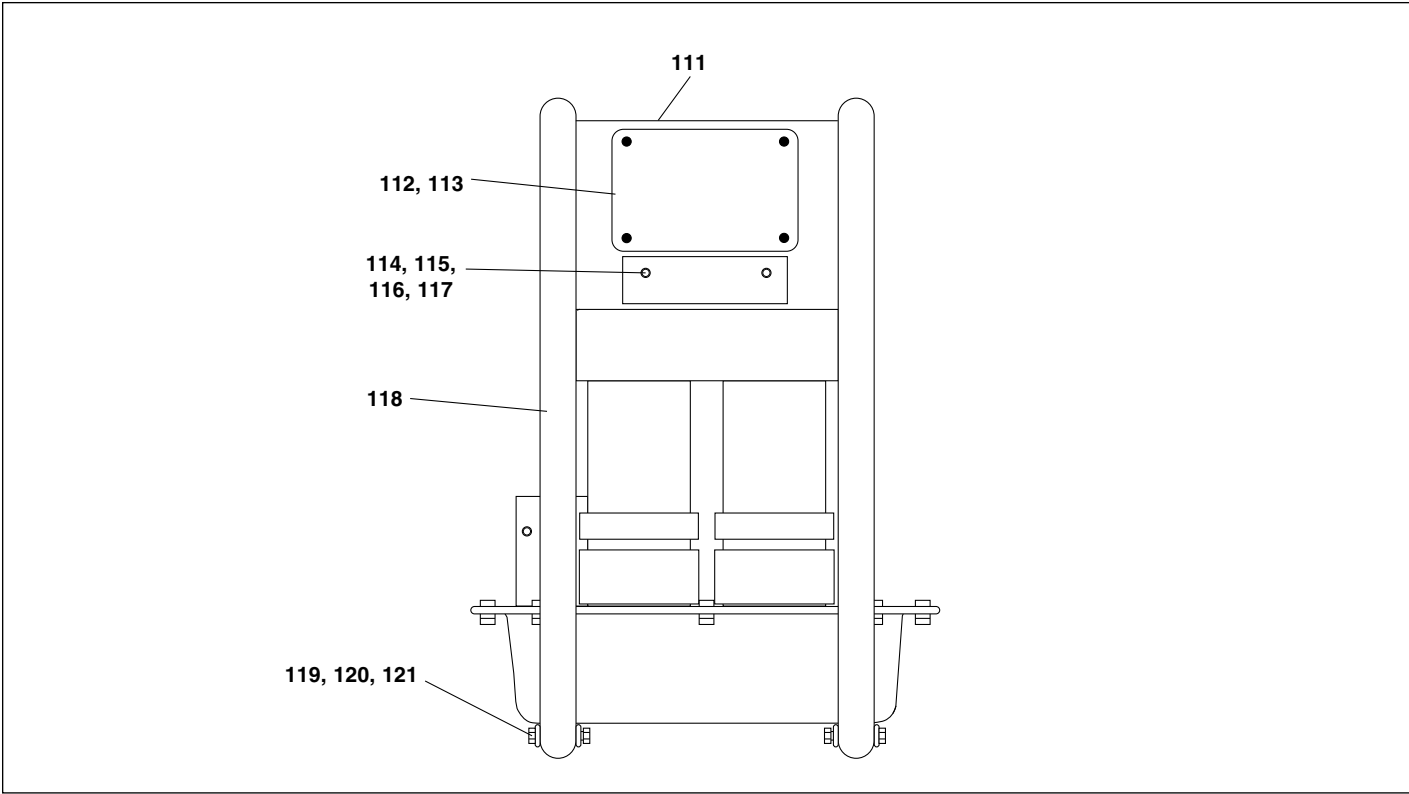

Figure 11, Roll-bar Model

Repair Parts List for Figure 11							
Item	Part Number	Qty.	Description	Item	Part Number	Qty.	Description
111	CB562026	1	Decal	118	CB526900SR	1	Roll Bar Assembly (For units with 1 Gallon Reservoir*)
112	Y697003	1	Rivet		CB525900W	1	Roll Bar Assembly (For units with 2 Gallon Reservoir*)
113	CN429026	1	Nameplate	119	B1001120	4	Nut
114	CB854026	1	Info Plate	120	CB528046	4	Cap Screw
115	F615120	2	Nut	121	F489066	4	Lock Washer
116	F658028	2	Machine Screw				
117	F614066	2	Lock Washer				

\* EAM-1021 and EAM-1041 have 1 gallon reservoirs.  
 \* EAM-1022 and EAM-1042 have 2 gallon reservoirs.

## Enerpac Worldwide Locations

◆ e-mail: [info@enerpac.com](mailto:info@enerpac.com)

◆ internet: [www.enerpac.com](http://www.enerpac.com)

### Australia and New Zealand

Actuant Australia Ltd.  
Block V Unit 3  
Regents Park Estate  
391 Park Road  
Regents Park NSW 2143  
(P.O. Box 261) Australia  
T +61 297 438 988  
F +61 297 438 648  
[sales-au@enerpac.com](mailto:sales-au@enerpac.com)

### Brazil

Power Packer do Brasil Ltda.  
Rua dos Inocentes, 587  
04764-050 - Sao Paulo (SP)  
T +55 11 5687 2211  
F +55 11 5686 5583  
Toll Free: 0800 891 5770  
[vendasbrasil@enerpac.com](mailto:vendasbrasil@enerpac.com)

### Canada

Actuant Canada Corporation  
6615 Ordan Drive, Unit 14-15  
Mississauga, Ontario L5T 1X2  
T +1 905 564 5749  
F +1 905 564 0305  
Toll Free:  
T +1 800 268 4987  
F +1 800 461 2456  
[customer.service@actuant.com](mailto:customer.service@actuant.com)

### China (Taicang)

Actuant (China) Industries Co. Ltd.  
No. 6 Nanjing Road,  
Taicang Economic Dep Zone  
Jiangsu, China  
T +86 0512 5328 7500  
F +86 0512 5335 9690  
[sales-cn@enerpac.com](mailto:sales-cn@enerpac.com)

### China (Beijing)

Actuant (China) Industries Co. Ltd.  
709B Diyang Building  
Xin No. 2, Dong San Huan North Rd.  
Beijing City, 100028 China  
T +86 10 845 36166  
F +86 10 845 36220  
[sales-cn@enerpac.com](mailto:sales-cn@enerpac.com)

### France, Switzerland, North Africa and French speaking African countries

ENERPAC  
Une division d'ACTUANT France  
S.A.S.  
ZA de Courtaboeuf  
32, avenue de la Baltique  
91140 VILLEBON /YVETTE  
France  
T +33 1 60 13 68 68  
F +33 1 69 20 37 50  
[sales-fr@enerpac.com](mailto:sales-fr@enerpac.com)

### Germany and Austria

ENERPAC GmbH  
P.O. Box 300113  
D-40401 Düsseldorf  
Willstätterstrasse 13  
D-40549 Düsseldorf, Germany  
T +49 211 471 490  
F +49 211 471 49 28  
[sales-de@enerpac.com](mailto:sales-de@enerpac.com)

### India

ENERPAC Hydraulics Pvt. Ltd.  
No. 1A, Peenya Industrial Area  
IInd Phase, Bangalore, 560 058, India  
T +91 80 40 792 777  
F +91 80 40 792 792  
[sales-in@enerpac.com](mailto:sales-in@enerpac.com)

### Italy

ENERPAC S.p.A.  
Via Canova 4  
20094 Corsico (Milano)  
T +39 02 4861 111  
F +39 02 4860 1288  
[sales-it@enerpac.com](mailto:sales-it@enerpac.com)

### Japan

Applied Power Japan LTD KK  
Besshocho 85-7  
Kita-ku, Saitama-shi 331-0821, Japan  
T +81 48 662 4911  
F +81 48 662 4955  
[sales-jp@enerpac.com](mailto:sales-jp@enerpac.com)

### Middle East, Egypt and Libya

ENERPAC Middle East FZE  
Office 423, LOB 15  
P.O. Box 18004, Jebel Ali, Dubai  
United Arab Emirates  
T +971 (0)4 8872686  
F +971 (0)4 8872687  
[sales-ua@enerpac.com](mailto:sales-ua@enerpac.com)

### Russia

Rep. office Enerpac  
Russian Federation  
Admiral Makarova Street 8  
125212 Moscow, Russia  
T +7 495 98090 91  
F +7 495 98090 92  
[sales-ru@enerpac.com](mailto:sales-ru@enerpac.com)

### Singapore

Actuant Asia Pte Ltd.  
83 Joo Koon Circle  
Singapore 629109  
T +65 68 63 0611  
F +65 64 84 5669  
Toll Free: +1800 363 7722  
[sales-sg@enerpac.com](mailto:sales-sg@enerpac.com)

### South Korea

Actuant Korea Ltd.  
3Ba 717, Shihwa Industrial Complex  
Jungwang-Dong, Shihung-Shi,  
Kyunggi-Do  
Republic of Korea 429-450  
T +82 31 434 4506  
F +82 31 434 4507  
[sales-kr@enerpac.com](mailto:sales-kr@enerpac.com)

### Spain and Portugal

ENERPAC SPAIN, S.L.  
Avda. Los Frailes, 40 – Nave C & D  
Pol. Ind. Los Frailes  
28814 Daganzo de Arriba  
(Madrid) Spain  
T +34 91 884 86 06  
F +34 91 884 86 11  
[sales-es@enerpac.com](mailto:sales-es@enerpac.com)

### Sweden, Denmark, Norway, Finland and Iceland

Enerpac Scandinavia AB  
Fabriksgatan 7  
412 50 Gothenburg  
Sweden  
T +46 (0) 31 799 0281  
F +46 (0) 31 799 0010  
[scandinavianinquiries@enerpac.com](mailto:scandinavianinquiries@enerpac.com)

### The Netherlands, Belgium, Luxembourg, Central and Eastern Europe, Baltic States, Greece, Turkey and CIS countries

ENERPAC B.V.  
Galvanistraat 115  
6716 AE Ede  
P.O. Box 8097  
6710 AB Ede  
The Netherlands  
T +31 318 535 800  
F +31 318 535 848  
[sales-nl@enerpac.com](mailto:sales-nl@enerpac.com)

Enerpac Integrated Solutions B.V.  
Opaalstraat 44  
7554 TS Hengelo  
P.O. Box 421  
7550 AK Hengelo  
The Netherlands  
T +31 74 242 20 45  
F +31 74 243 03 38  
[integratedsolutions@enerpac.com](mailto:integratedsolutions@enerpac.com)

### South Africa and other English speaking African countries

ENERPAC B.V.  
Galvanistraat 115  
6716 AE Ede  
P.O. Box 8097  
6710 AB Ede  
The Netherlands  
T +31 318 535 911  
F +31 318 525 613  
[sales-za@enerpac.com](mailto:sales-za@enerpac.com)

### United Kingdom and Ireland

ENERPAC Ltd.,  
Bentley Road South  
Darlaston, West Midlands  
WS10 8LQ  
England  
T +44 (0)121 50 50 787  
F +44 (0)121 50 50 799  
[sales-uk@enerpac.com](mailto:sales-uk@enerpac.com)

### USA, Latin America and Caribbean

ENERPAC  
P.O. Box 3241  
6100 N. Baker Road  
Milwaukee  
WI 53209 USA  
T +1 262 781 6600  
F +1 262 783 9562  
User inquiries:  
+1 800 433 2766  
Distributor inquiries/orders:  
+1 800 558 0530  
[sales-us@enerpac.com](mailto:sales-us@enerpac.com)

All Enerpac products are guaranteed  
against defects in workmanship and  
materials for as long as you own them.

For the location of your nearest authorized  
Enerpac Service Center, visit us at  
[www.enerpac.com](http://www.enerpac.com)