

Index:

English	1-11
Français	12-22

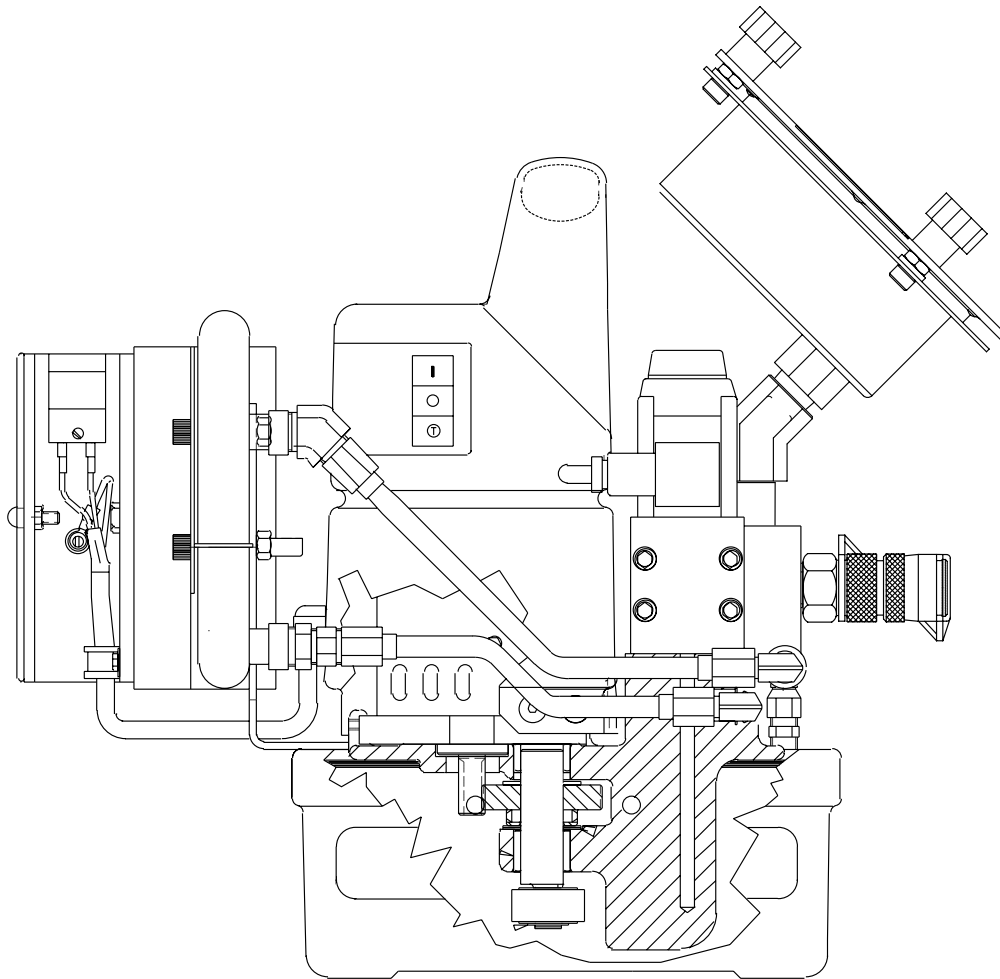

Contents:

Figure 1 - Pump Side View	2	Figure 11 - Shroud Wiring-Front of Motor	6
Figure 2 - Pump Front View (shroud removed).....	2	Figure 12 - Shroud Wiring-Left of Motor	6
Figure 3 - Relief Valve.....	2	Figure 13 - Shroud Wiring-Right of Motor.....	6
Figure 4 - Pump Bottom View	2	Figure 14 - Top View-Cord and Cables	7
Figure 5 - Heat Exchanger	3	Figure 15 - Pendant Assembly	8
Figure 6 - Pump Front View (assembled)	3	Figure 16 - Poppet Valve.....	8
Figure 7 - Pump Top View	4	Figure 17 - Poppet Valve Assembly	9
Figure 8 - Wiring Diagram	4	Figure 18 - Poppet Valve Assembly	10
Figure 9 - Wiring Diagram	5	Figure 19 - Unloading Valve	10
Figure 10 - Shroud Wiring-Behind Motor.....	6	Figure 20 - Electrical Schematic	11

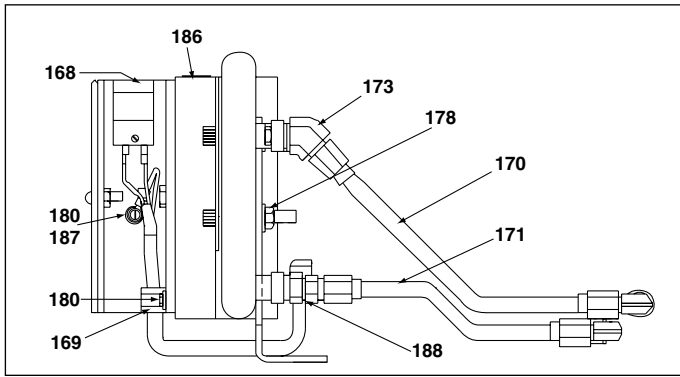

Figure 5, Heat Exchanger

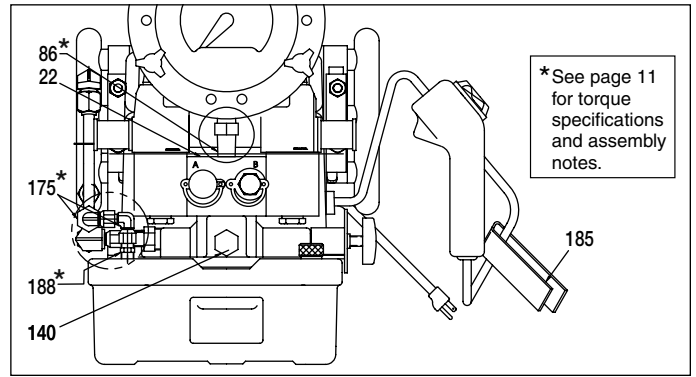

Figure 6, Pump Front View (assembled)

Repair Parts List for Figures 1 through 6

Item	Part Number	Qty.	Description
2	★ DA12088167SR	1	Gasket (Includes item 156)
3	DA1910900SR	1	Reservoir Assembly
10	DA3776006	2	Pin
14	DA15066	4	Lock Washer
15	B1018121	4	Hex Nut
17	CW261225	6	Eyelet
18	F866028	6	Machine Screw
19	CW259298	1	Baffle
22	DA5476900SR	1	115V Poppet Valve Ass'y
	DA5477900SR	1	220V Poppet Valve Ass'y
25	Contact Enerpac	1	Nameplate
26	DC818003	4	Pop Rivet
27	DA608024	1	Vent Plug
28	★ B1906503	1	O-Ring
36	DA931225	2	Insert
42	DC3760900	1	Gauge
77	DA5775190	1	Adjusting Screw Body
78	★ B1003503	1	O-Ring
79	CB815381	1	Knob
80	DC5714028	1	Set Screw
81	B1080066	3	Lockwasher
82	B1326028	3	SHCS
83	DA7858147	3	Knob
84	DC2926004	1	Flange
85	DC2290900	1	Overlay Kit
86	F100095	1	Fitting, 45°
87	B1018121	3	Hex Nut
101	DA12490840SR	1	Pump Manifold (includes # 121)
102	CW179259	1	115 VAC Motor
	DC1415259	1	220 VAC Motor (50 Hz)
105	CW298950SR	1	.53 Piston Block Assembly
106	★ B1007503	1	O-Ring
107	CW299950SR	1	.24 Piston Block Assembly
108	★ B1012803	1	O-Ring
109	B1010028X	4	Screw
110	CW252107	1	Bearing
114	CW301228	1	Driven Gear
115	★ B1097057	1	Spring Pin
116	★ CW199107	1	Bearing
117	CW251107	1	Bearing
118	CW302107	1	Bearing
119	CW303104	1	Shaft
121	DA5999900SR	1	Relief Valve (see Figure 4)
122	★ C846037	1	Gasket
123	★ DA5771290	1	Seat
125	DC1316900SR	1	Ball Guide Assembly
126	★ DA3282110	1	Compression Spring

★ Included in Repair Kit PME10427K

Item	Part Number	Qty.	Description
127	DA5772013	1	Spring Guide
128	DA5773048	1	Adjusting Screw
129	★ S1167	1	Gasket
130	DA5774021	1	Lock Nut
140	R515245-2	1	Plug
142	B202291	1	Elbow
143	DA7000268	1	Tube
144	★ CW467044	1	Retaining Ring
145	★ DA445107	2	Bearing
146	★ B1007016	1	Ball
147	★ DA1564110	1	Spring
149	DA5859028	4	Cap Screw
150	DA1015950SR	1	Relief Valve Assembly
151	DA5849092	1	Elbow Fitting
152	Y714291	1	Elbow
153	★ C642395	1	Nipple
154	★ CU876028	3	Screw (10-24)
155	DA3585186	3	Spacer
156	See item 2	1	Gasket
157	★ DA9628900SR	1	Unloading Valve Assembly
158	DC834900SR	1	Spring Guide Assembly
161	DA5879026	1	Warning Decal
163	F100097-52	2	Male Elbow, 90°
164	DC1939268	1	Nylon Tubing
165	F100097-33	1	Connector, Male
166	CJ657032	1	Bushing, Reducer
168	DA9432471	1	Heat Exchanger, 115V
	DA9572471	1	Heat Exchanger, 220V
169	Y99017	1	Strap
170	DA9511268	1	Tube
171	DA9512268	1	Tube
173	F100094102	1	45° Elbow
174	F100094-5	1	Connector, Male
175	F100094-210	3	Elbow
178	CBE1080120-2A	4	Lock Nut
180	CU876028	2	Screw
181	DA7567028	1	Screw
185	DA7570217	1	Cord Strap
186	DA9590026	1	Decal, Spartan
187	B1080066	1	Lockwasher
188	CA945096	2	Connector
190	DA12352290	1	Ball Seat
196	★ C332291	1	Fitting
200	★ DC1947167	1	Gasket

Replacement Brushes for Electric Motor

---	DA9584380SR	1	Brush Set for 115V Models
---	DA9585380SR	1	Brush Set for 220V Models

* See page 11 for torque specifications and assembly notes.

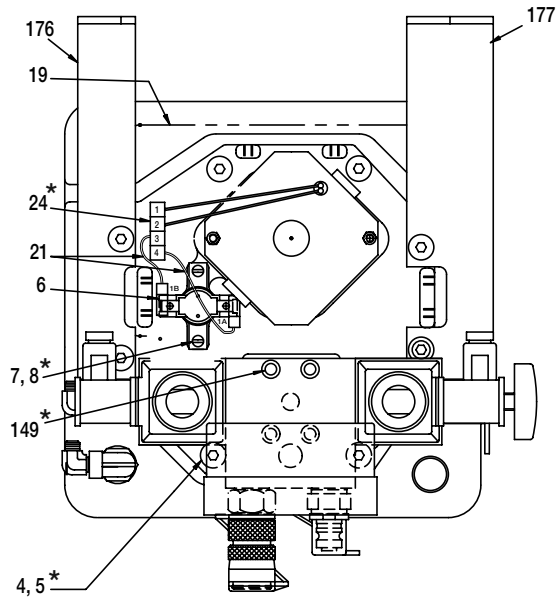
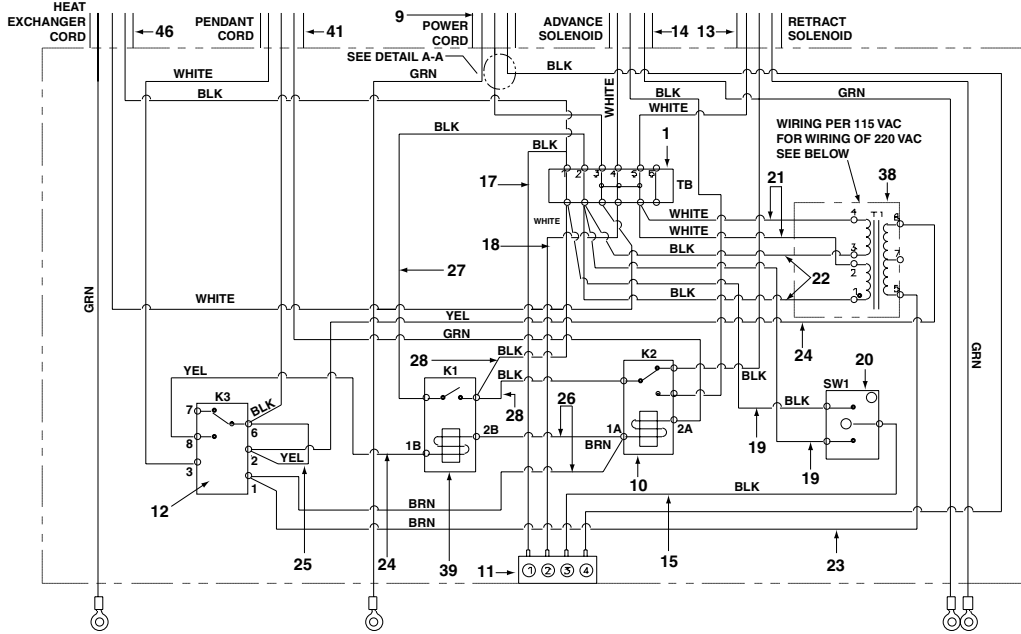

Figure 7, Pump Top View

Repair Parts List for Figure 7

Item	Part Number	Qty.	Description
4	DA6954167	8	Gasket
5	DC2038028	8	Screw
6	DA5135380	1	Thermostat
7	C701222	2	Washer
8	M642028	2	Screw
19	CW259298	1	Baffle
21	DC7969960	2	Wire Assembly
24	DA11540380	1	Pin Housing
149	DA5859028	4	Cap Screw
176	DA9439111	1	Bracket, Right
177	DA9438111	4	Bracket, Left



FOR 220 VAC WIRING

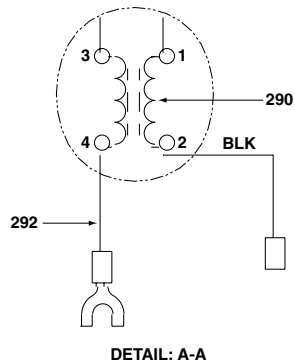

220 VAC WIRING

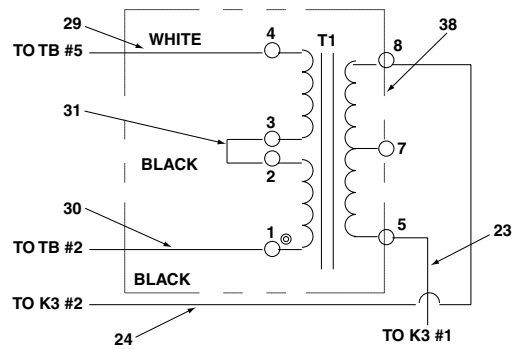

REF:4101F7

Figure 8, Wiring Diagram (Note: See pump wiring chart on next page.)

Pump Wiring Chart for 115 VAC and 220 VAC Models (Refer to Figure 8)

Voltage	Item	Color	Wiring Connection	Voltage	Item	Color	Wiring Connection
both	15	Black	(Item 11, terminal 3) to (Item 20, terminal 3A)	both	25	Yellow	(Item 12, terminal 6) to (Item 12, terminal 2)
both	17	Black	(Item 11, terminal 1) to (Item 1, terminal 1)	both	26	Brown	(Item 10, terminal 1A) to (Item 39, terminal 2B and Item 12, terminal 1)
both	18	White	(Item 11, terminal 2) to (Item 1, terminal 4)	both	27	Black	(Item 39, COM terminal) to (Item 1, terminal 2)
both	19	Black	(Item 20, terminal 3B) to (Item 1, terminal 1)	both	28	Black	(Item 39, NO terminal) to (Item 10, COM terminal and Item 1, terminal 1)
both	19	Black	(Item 20, terminal 3C) to (Item 1, terminal 2)	115 VAC 115 VAC 115 VAC	9	Black White Green	connect to Item 11, terminal 4 connect to Item 1, terminal 3 connect to motor, terminal 1C
115 VAC	21	White	(Item 1, terminal 5) to (Item 38, terminals 2 and 4)	220 VAC 220 VAC 220 VAC	9	Black White Green	(Item 290, terminal 1) (Item 290, terminal 3) connect to motor, terminal 1C
115 VAC	22	Black	(Item 1, terminal 2) to (Item 38, terminals 1 and 3)	both	13	Black White Green	connect to Item 10, NC terminal connect to Item 1, terminal 5 connect to motor, terminal 1D
220 VAC	29	White	(Item 1, terminal 5) to (Item 38, terminal 4)	both	14	Black White Green	connect to Item 10, NO terminal connect to Item 1, terminal 4 connect to motor, terminal 1D
220 VAC	30	Black	(Item 1, terminal 2) to (Item 38, terminal 1)	both	41	Black White Green	connect to Item 12, terminal 6 connect to Item 12, terminal 3 connect to Item 10, terminal 2A
220 VAC	31	Black	(Item 38, terminal 2) to (Item 38, terminal 3)	220 VAC	290	Black	(Item 11, terminal 4)
both	23	Brown	(Item 12, terminal 1) to (Item 38, terminal 5)	220 VAC	292	White	(Item 290, terminal 4) to (Item 1, terminal 3)
both	24	Yellow	(Item 12, terminal 2) to (Item 38, terminal 8)				
both	24	Yellow	(Item 12, terminal 8) to (Item 39, terminal 1B)				

NOTE: Refer to parts list on page 7 for part numbers and descriptions of additional items shown in Figure 8

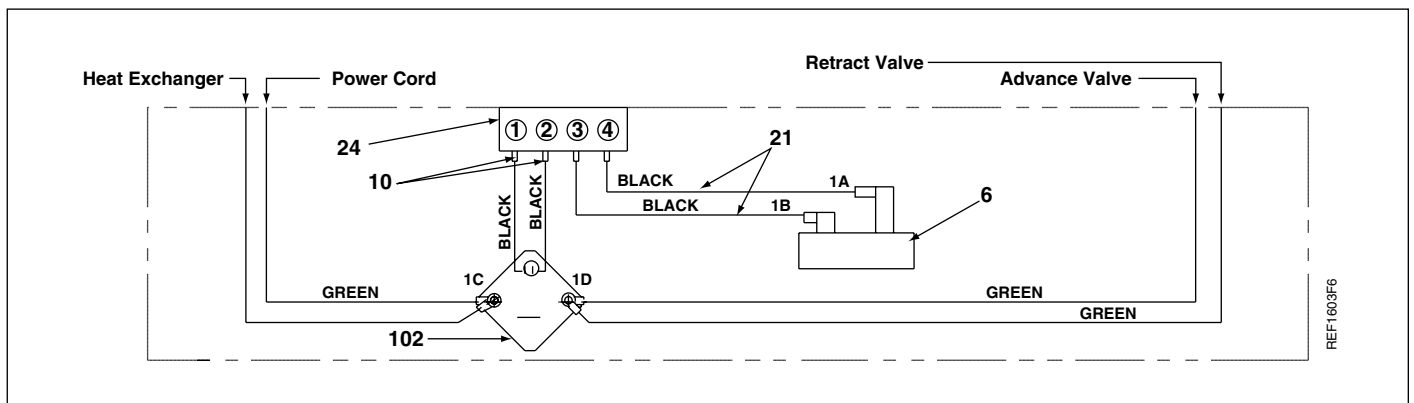

Figure 9, Wiring Diagram

Repair Parts List for Figure 9

Item	Part Number	Qty.	Description	Item	Part Number	Qty.	Description
6	DA5135380	1	Thermostat	24	DA11540380	1	Pin Housing
10	DA3776006	2	Pin	102	CW179259	1	Motor, 115VAC
21	DA3712900SR	2	Wire Assembly		DC1415259	1	Motor, 220VAC (50Hz)

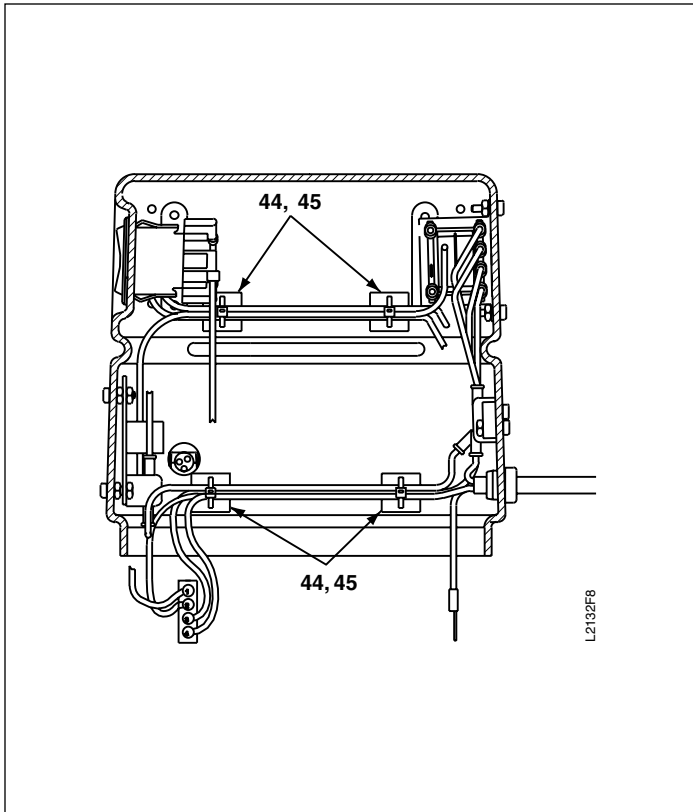

Figure 10, Shroud Wiring - Behind Motor

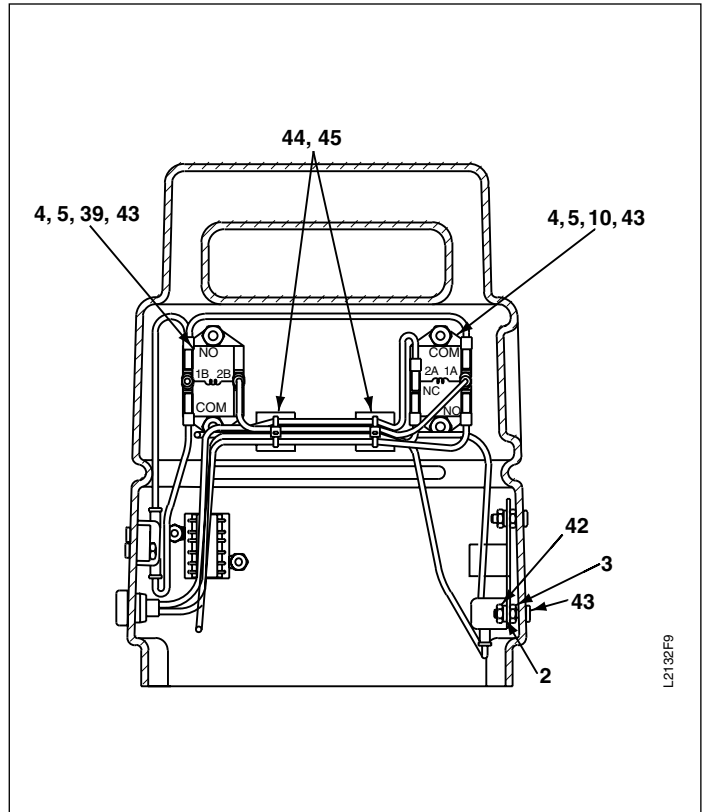

Figure 11, Shroud Wiring - Front of Motor

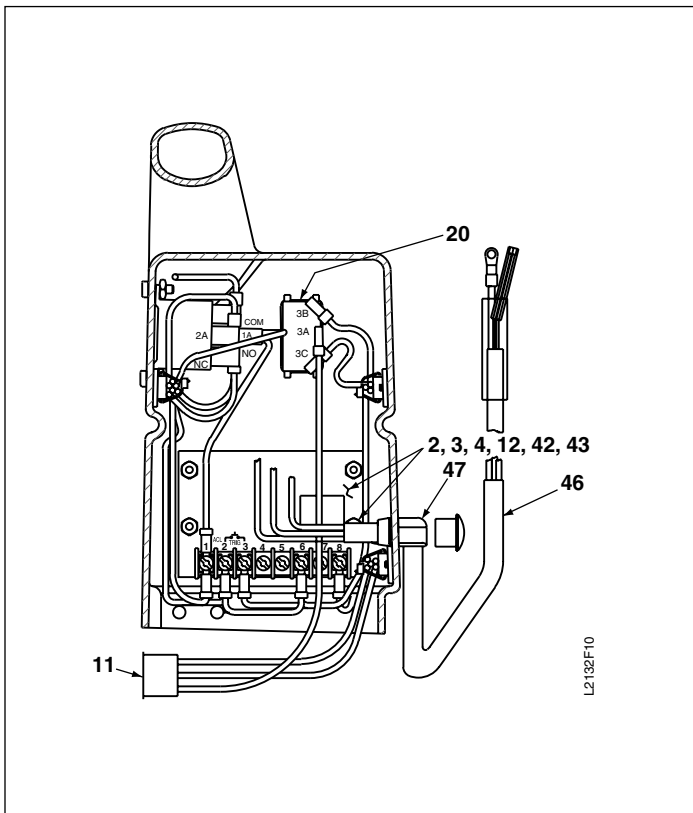

Figure 12, Shroud Wiring - Left of Motor

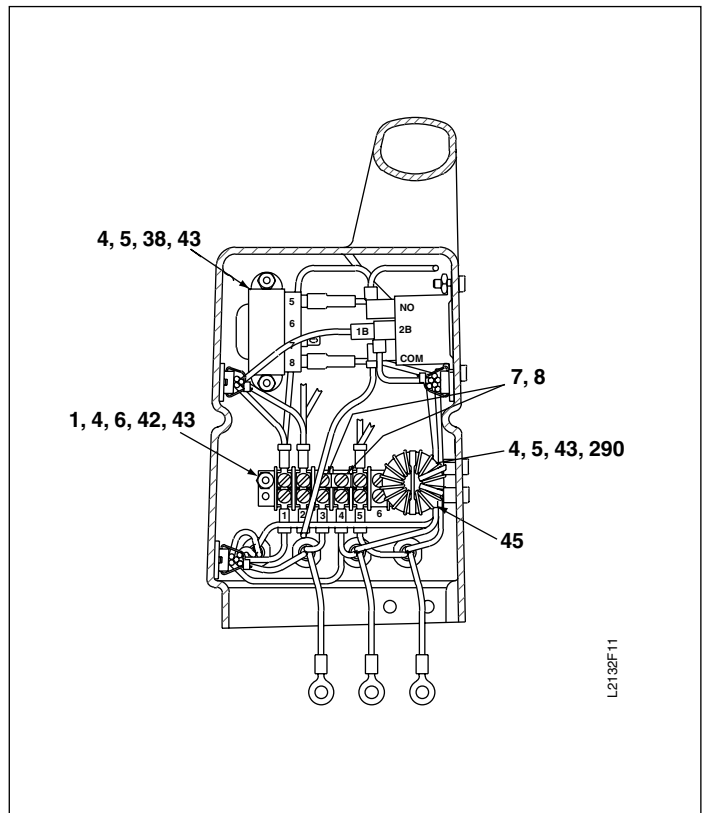

Figure 13, Shroud Wiring - Right of Motor

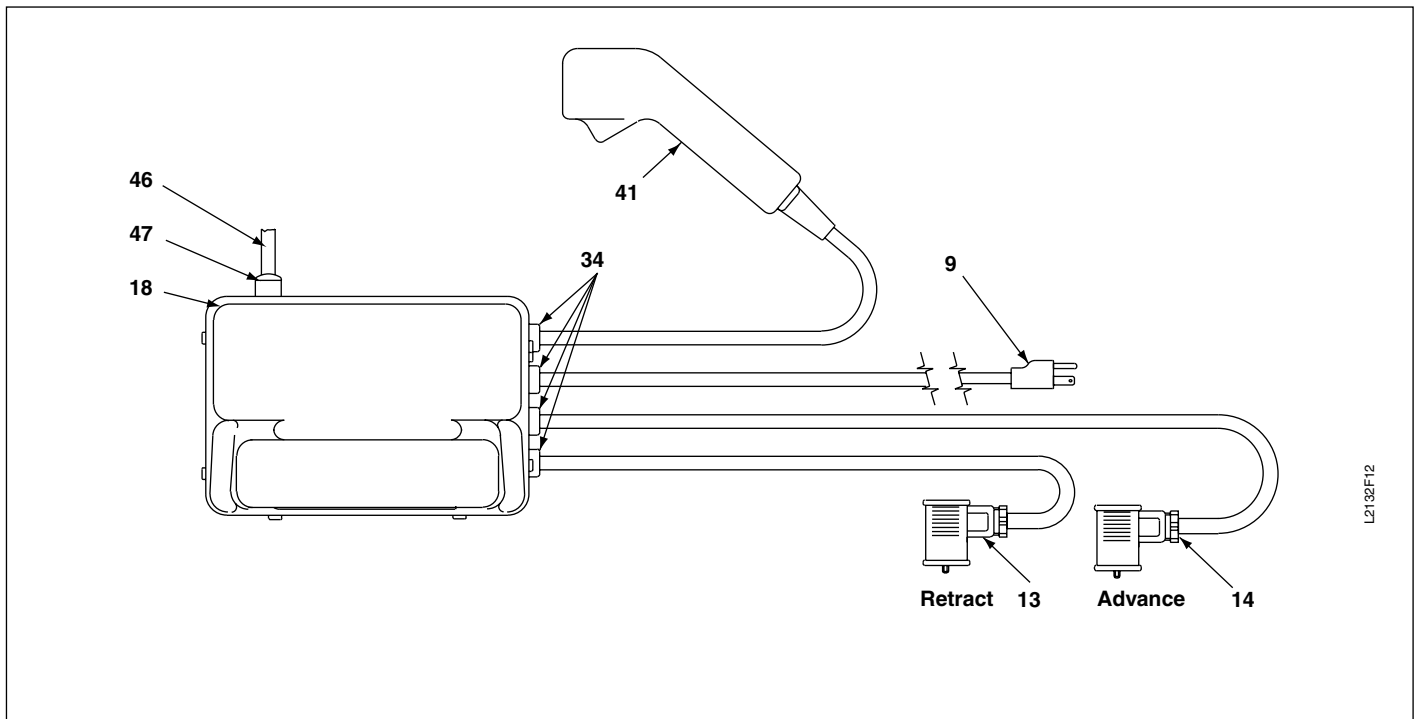

Figure 14, Top View, Cord and Cables

L2132F12

Repair Parts List for Figures 10-14

Item	Part Number	Qty.	Description	Item	Part Number	Qty.	Description
1	DA5884199	1	Terminal Strip	14	DA5917900SR	1	Solenoid Cable Assembly
2	CH890108	4	Back-Up Washer	18	DA5921900SR	1	Wire Assembly
3	DA5909021	4	Nylon Nut #6-32	20	E1500002	1	Switch
4	BC1310728	12	Screw (115V)	34	CR759291	4	Cord Bushing
	BC1310728	14	Screw (220V)	38	DA5875380	1	Transformer
5	F75021	6	Lock Nut, #6-32 (115V)	39	E1300008	1	Relay d1
	F75021	8	Lock Nut, #6-32 (220V)	41	DA5799900SR	1	Pendant Assembly (Fig. 15)
6	DA5801199	1	Terminal Marker Strip	42	B1013121	6	Hex Nut
7	DA5803199	2	Terminal Jumper	43	DA5974098	12	Screw Cover (115V)
8	DA5802199	1	Terminal Cover		DA5974098	14	Screw Cover (220V)
9	DA5913900SR	1	Power Cord, 115VAC	44	EHC3901075	6	Tie Down
	DA3728900SR	1	Power Cord, 220VAC	45	DA3131217	7	Wire Tie
10	DA5581980	1	Relay	46	DC9520900	1	Heat Exchanger Cord
11	DA11539380	1	Socket Housing	47	DA9521380	1	Bushing
12	DA9284980	1	Time Delay Relay	290	DC374900	1	Choke Assy. (220V only)
13	DA5915900SR	1	Solenoid Cable Assembly				

★ Note: For replacement shroud assembly, order Repair Kit DC7940900SR (115V) or DC7941900SR (220V).

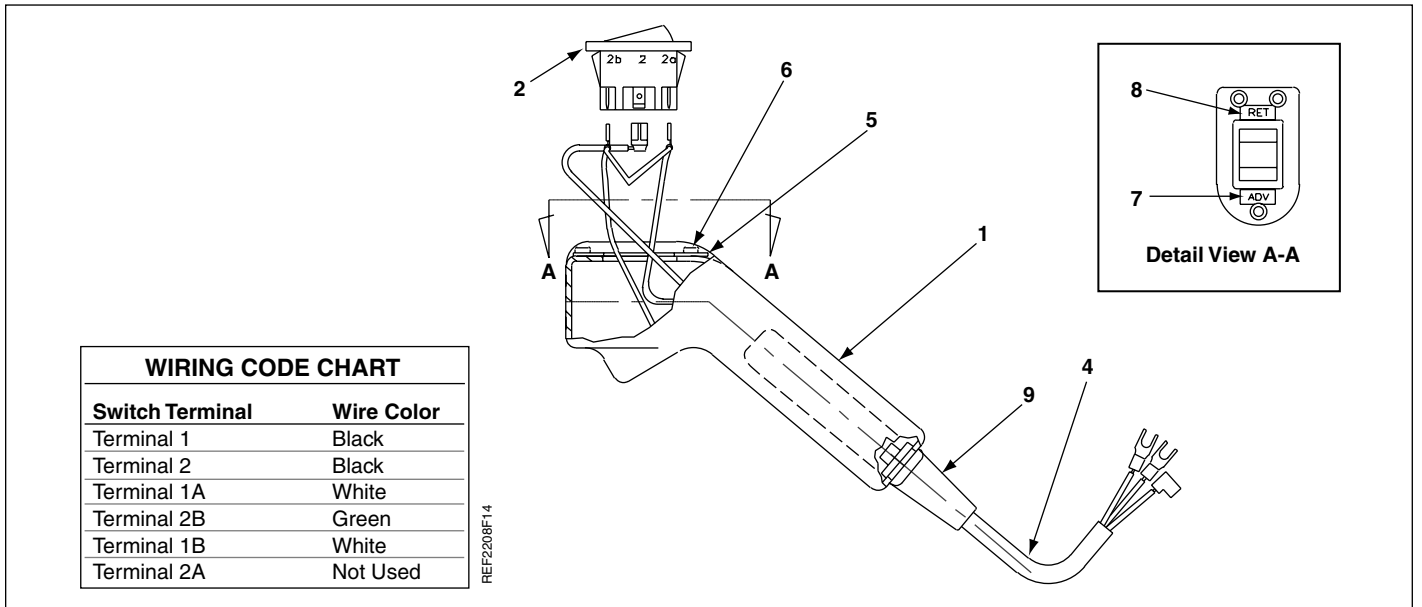

Figure 15, Pendant Assembly

Repair Parts List for Figure 15							
Item	Part Number	Qty.	Description	Item	Part Number	Qty.	Description
1	★DA1323190	1	Pendant Body	7	★DA1686026	1	Decal
2	★E1500001	1	Rocker Switch	8	★DA2804026	1	Decal
4	★DA5912900SR	1	Cord Assembly	9	★DA1568007	1	Strain Relief
5	★DA1415101	1	Mounting Plate	185	★DA7570217	1	Cord Strap (see Fig. 6)
6	★DC818003	3	Pop Rivet				

★ Repair Kit DA5799900SR includes a complete pendant assembly (all items listed above).

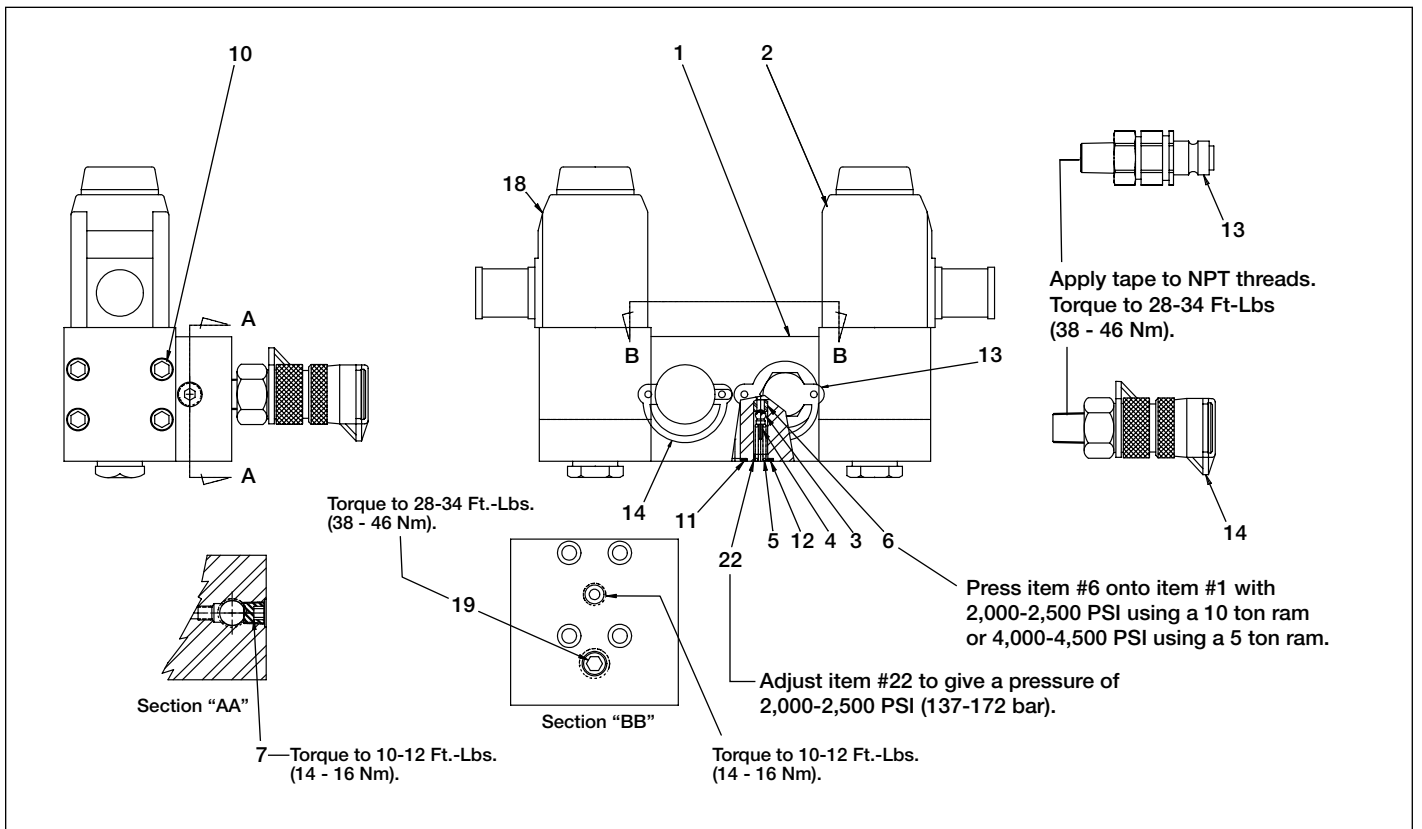

Figure 16, Poppet Valve

Repair Parts List for Figure 16

Item	Part Number	Qty.	Description	Item	Part Number	Qty.	Description
1	▲★ DC4920190	1	Body	11	▲★ B1011803	1	O-Ring
2	VSG2310P	1	Poppet Valve, 115V (see Fig. 17)	12	▲★ B1231503	2	O-Ring
	VSG3510P	1	Poppet Valve, 220V (see Fig. 17)	13	DC6432034	1	Male Coupler
3	▲★ B1005016	1	3/16" Ball	14	DC6431034	1	Female Coupler
4	▲★ F522570	1	Ball Cap	18	DC847900SR	1	Poppet Valve, 115V (see Fig. 18)
5	▲★ A8238110	1	Compression Spring		DC848900SR	1	Poppet Valve, 220V (see Fig. 18)
6	▲★ A8015290	1	Seat	19	▲ A1008245	1	Pipe Plug - 3/4"
7	▲★ A1007245	2	Pipe Plug - 1/8"	22	▲★ DC5840048	1	Hollow Lock Screw
10	▲ B1022028	8	Screw				

★ Indicates items included in Repair Kit DA5476900K.
(Repair Kit DA5476900K is included in Pump Repair Kit PME10427K.)

▲ Indicates items included in Repair Kit DA5850190SR.

Note: Body DC4920190 in Kit DA5850190SR now has 1/4 NPTF ports.
Be sure you have couplers with 1/4 NPTF threads or order DC6432034 and DC6431034 couplers.

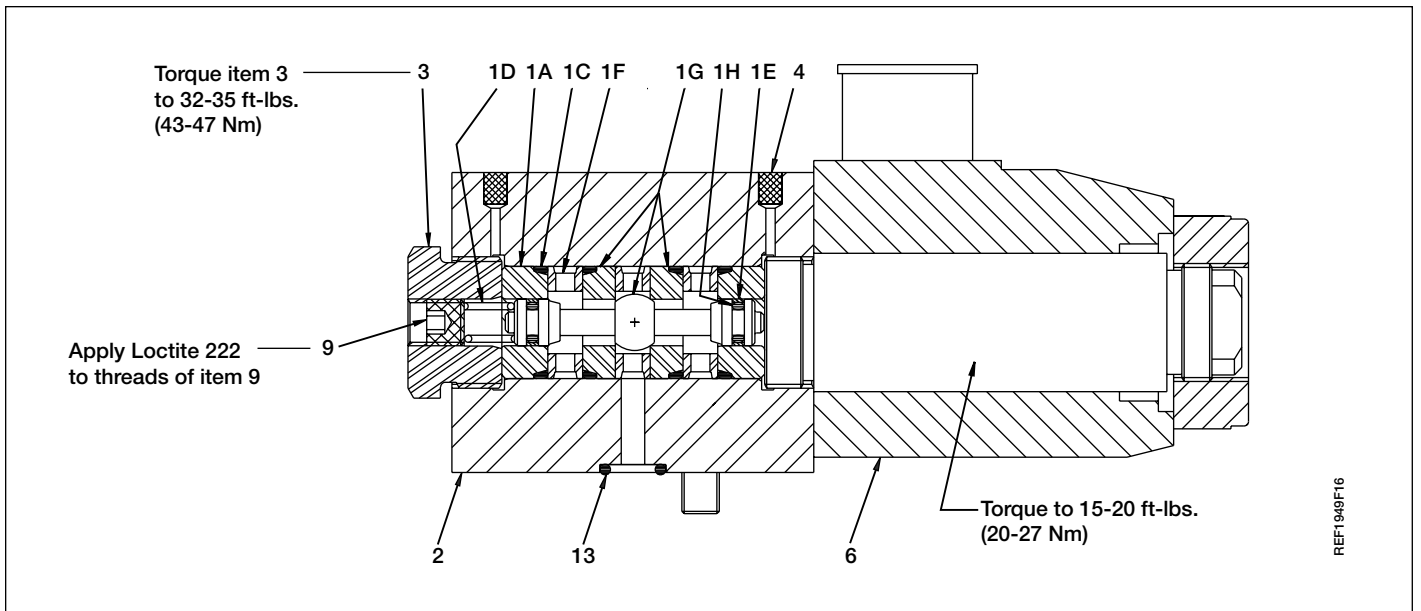

Figure 17, Poppet Valve Assembly

Repair Parts List for Figure 17

Item	Part Number	Qty.	Description	Item	Part Number	Qty.	Description
1	★ DA5792949SR	1	Valve Stack (inc. items 1A-1H)	2	DA4393190	1	Valve Block Body
1A	DA3697039	2	Bushing	3	DA5421009	1	Valve Plug
1C	† B1016803	4	O-ring	4	† DA4390118	2	Filter
1D	† DA5422110	1	Comp. Spring	6	DA4405900	1	Solenoid Assembly (115V)
1E	† CH279044	2	Glyd Ring		DA5714900	1	Solenoid Assembly (220V)
1F	DA3698290	3	Seat Spacer	9	PA1417027	1	Set Screw
1G	DC862949	1	Poppet Set	13	▲★ B1011803	3	O-Ring
1H	† B1002503	2	O-Ring				

★ Indicates items included in Repair Kit DA5476900K.
† Indicates items included in Repair Kit DA5792949SR.
(Repair Kit DA5476900K is included in Pump Repair Kit PME10472K.)

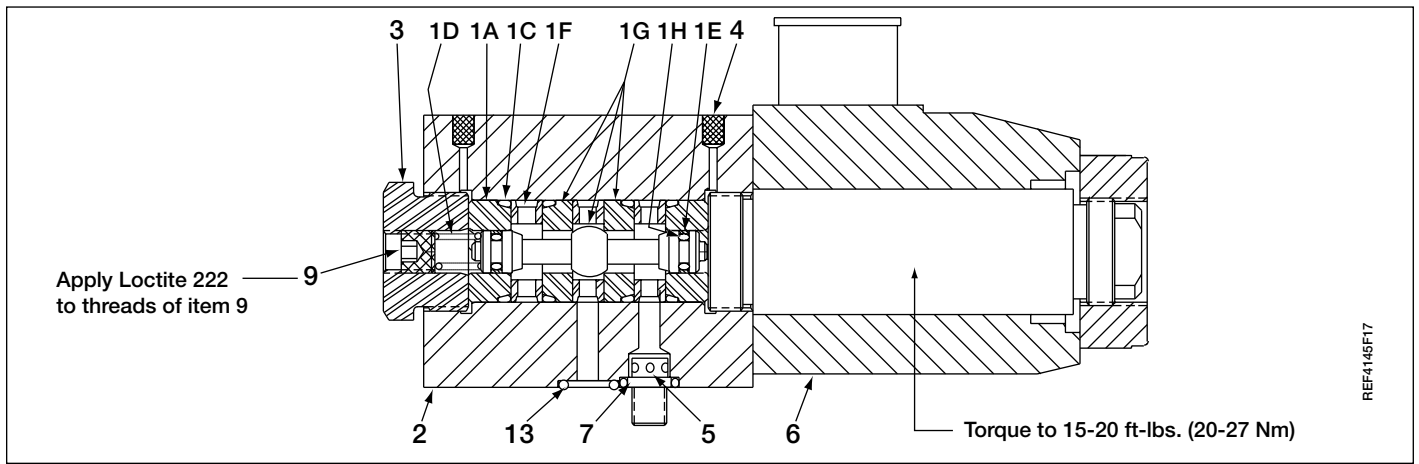

Figure 18, Poppet Valve Assembly

Repair Parts List for Figure 18

Item	Part Number	Qty.	Description	Item	Part Number	Qty.	Description
1	★ DA5792949SR	1	Valve Stack (inc. items 1A-1H)	3	DA5421009	1	Valve Plug
1A	★ DA3697039	2	Bushing	4	★† DA4390118	2	Filter
1C	★† B1016803	4	O-ring	5	DC844661SR	1	Check Valve
1D	★† DA5422110	1	Comp. Spring	6	DA4405900	1	Solenoid Assembly (115V)
1E	★† CM279044	2	Glyd Ring		DA5714900	1	Solenoid Assembly (220V)
1F	★ DA3698290	3	Seat Spacer	7	★† B1006503	1	O-Ring
1G	★ DC862949	1	Poppet Set	9	PA1417027	1	Set Screw
1H	★† B1002503	2	O-Ring	13	★† B1011803	3	O-Ring
2	DC846190	1	Valve Block Body				

★ Indicates items included in Repair Kit DA5476900K.
 Repair Kit DA5476900K includes (2) DA5792949K Repair Kits.
 Repair Kit DA5476900K is included in Pump Repair Kit PME10427K.
 † Items included in Repair Kit DA5792949K.

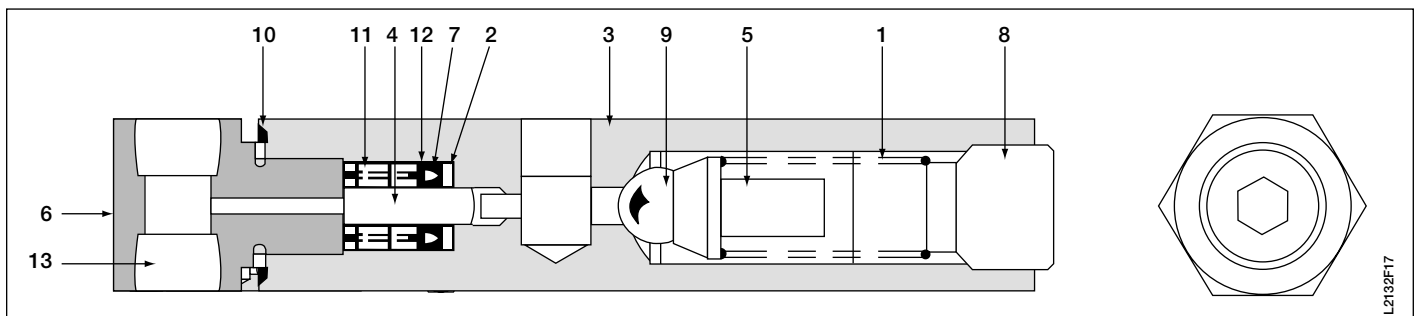

Figure 19, Unloading Valve

Repair Parts List for Figure 19

Item	Part Number	Qty.	Description	Item	Part Number	Qty.	Description
1	★ DA3282110	1	Compression Spring	8	C641087	1	Screw
2	★ SJ100016	1	Back-Up Washer	9	★ B1009016	1	Ball
3	DA9628900SR	1	Valve Assembly (Complete)	10	★ S15167	1	Gasket
4	C622339	1	Plunger	11	★ S4375	1	Spring
5	DA3284160	1	Ball Retainer	12	★ B1024562	1	Leather Back-Up Ring
6	DA3285038	1	Adaptor	13	A1007245	1	Pipe Plug
7	★ C639053	1	U-Cup				

★ Indicates items included in Repair Kit DA3281900K.
 (Repair Kit DA3281900K is included in Pump Repair Kit PME10427K).

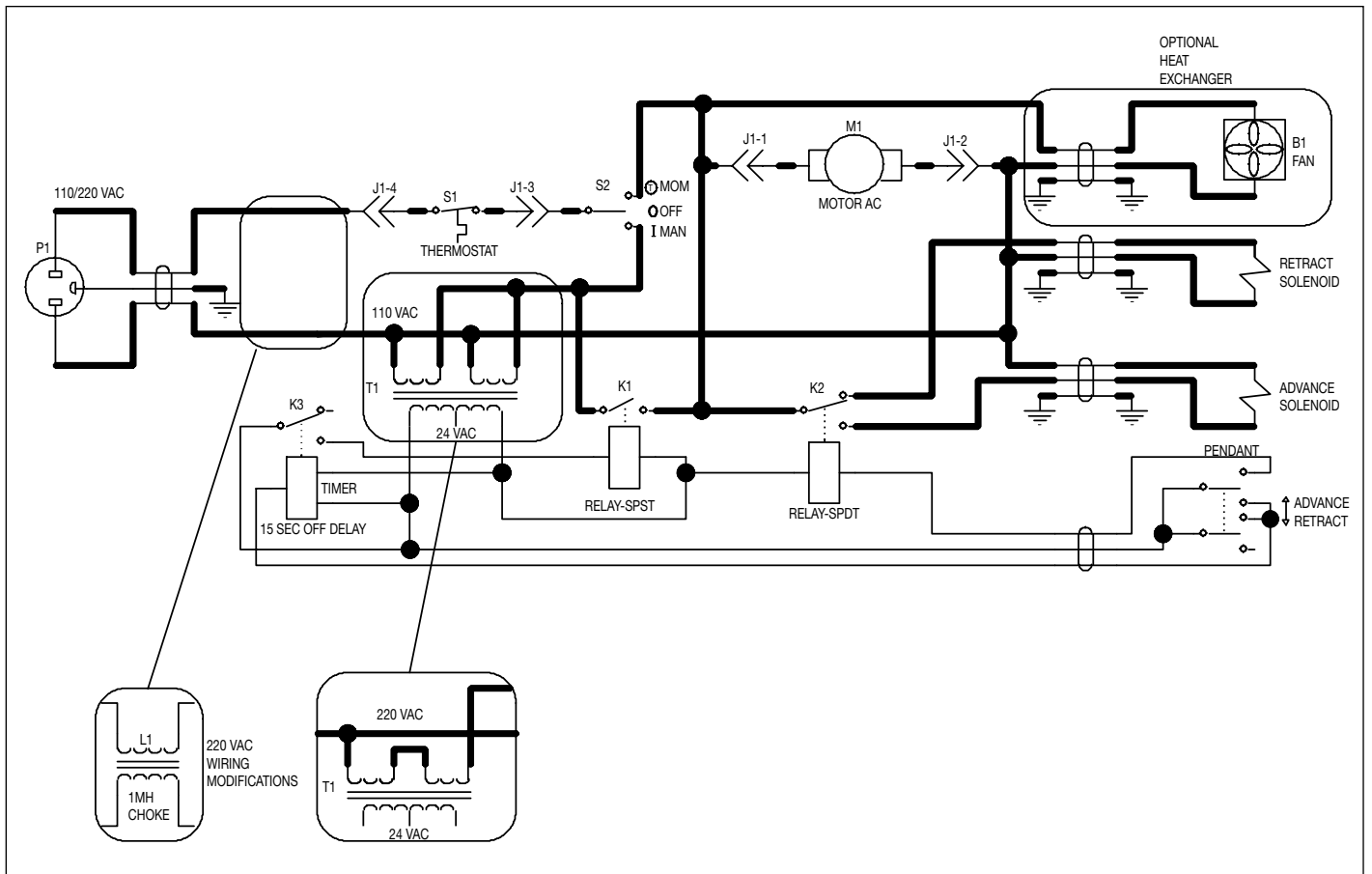
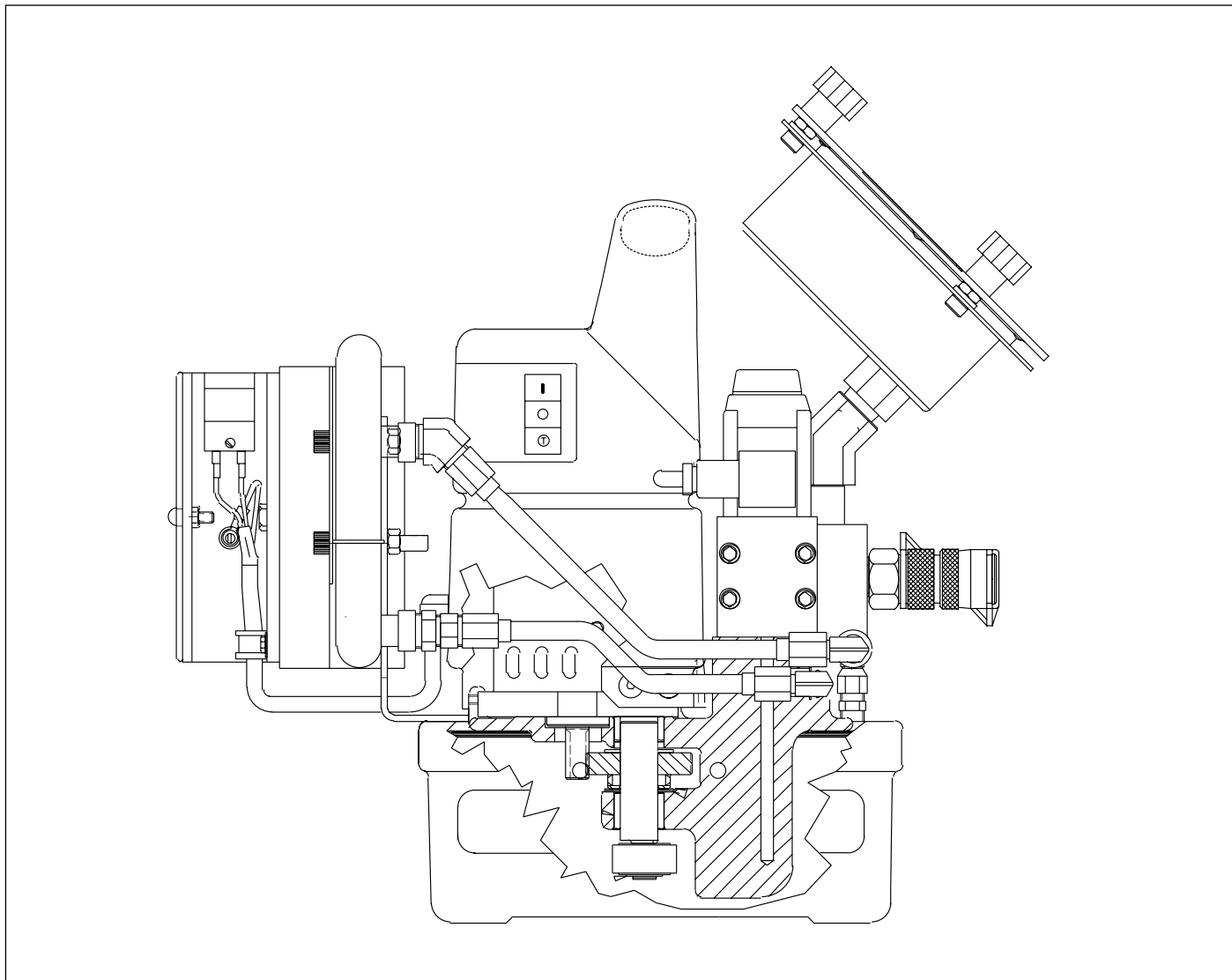

Figure 20, Electrical Schematic

Figure	Item No.	Torque Specification and/or Assembly Notes
1	18	Apply 1 drop Loctite #242 to threads. Torque to 12 to 18 in-lbs (1,4 to 2,0 Nm).
1	42	Torque to 24-30 ft-lbs (32 to 40 Nm).
1	82	Torque to 18-25 in-lbs (2,0-2,8 Nm). Hold item 87 against gauge while securing item 82.
1	Note 1	Install bearing, Item 117, flush to 0.010" (2,54 mm) recessed from surface.
2	10	Trim wire length to 9 to 10 inches (228 - 254 mm) before attaching pins (item 10). Then insert into item 24.
2	15	Torque to 20 to 25 in-lbs, dry (2,2 to 2,8 Nm).
3	77	Torque to 15 to 20 ft-lbs (20 to 27 Nm).
3	123	Torque to 15 to 16 ft-lbs (20,0 to 21,7 Nm) lubricated.
4	15	Torque to 31-33 in-lbs, dry (3,5 to 3,7 Nm).
4	109	Torque to 14 to 16 ft-lbs, dry (19,0 to 21,7 Nm).
4	121	Torque to 16-19 ft-lbs, dry (21,7 to 25,8 Nm).
4	146	Seat must be coined.
4	150	Valve setting should be from 10 to 30 psi (0,7 to 2,0 bar).
4	157	Relief valve setting should be from 625 to 825 psi (43,2 to 56,8 bar).
4	190	Assemble with Loctite #609.
4	Note 2	Stake threads after setting pressure.
6	86	Torque to 44 to 53 ft-lbs (60 to 71 Nm). Connection must be leak free at operating pressure.
6	175, 188	Assemble oil cooler fittings and torque to 10-12 ft-lbs. Use Teflon tape on pipe threads. Use Loctite 242 on tube nuts and torque to 18-22 ft-lbs.
7	149	Torque to 8 to 10 ft-lbs (10,8 to 13,5 Nm).
7	5	Torque to 49-52 ft-lbs, dry (66 to 70 Nm).
7	8	Torque to 8-12 in-lbs (0,9-1,35 Nm).
7	24	Attach to receptacle on shroud.



Contents:

Figure 1 - Vue latérale de la pompe	13	Figure 12 - Câblage de la tôle de protection – côté gauche du moteur.....	17
Figure 2 - Vue avant de la pompe (Sans la tôle de protection)	13	Figure 13 - Câblage de la tôle de protection – côté droit du moteur	17
Figure 3 - Valve de décharge.....	13	Figure 14 - Vue de dessus – cordons et câbles	18
Figure 4 - Vue de dessous de la pompe	13	Figure 15 - Pupitre mobile.....	19
Figure 5 - Échangeur de chaleur	14	Figure 16 - Soupape à champignon.....	19
Figure 6 - Vue avant de la pompe (assemblée).....	14	Figure 17 - Ensemble soupape à champignon	20
Figure 7 - Vue de dessus de la pompe.....	15	Figure 18 - Ensemble soupape à champignon	21
Figure 8 - Schéma de câblage	15	Figure 19 - Soupape d'allègement.....	21
Figure 9 - Schéma de câblage	16	Figure 20 - Schéma électrique	22
Figure 10 - Câblage de la tôle de protection – derrière le moteur.....	17		
Figure 11 - Câblage de la tôle de protection – devant le moteur	17		

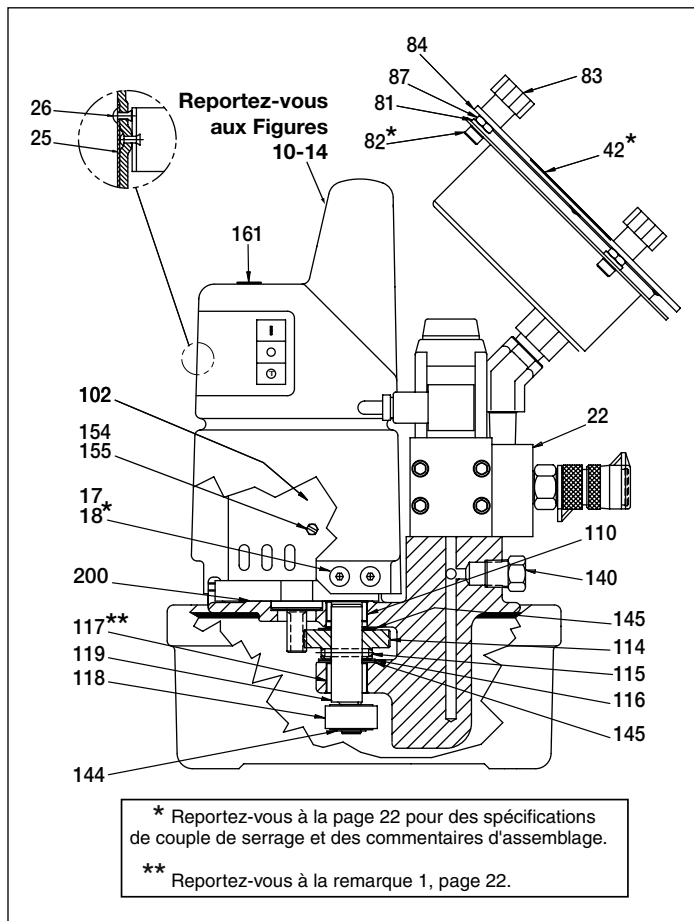

Figure 1, Vue latérale de la pompe (l'échangeur de chaleur n'est pas représenté)

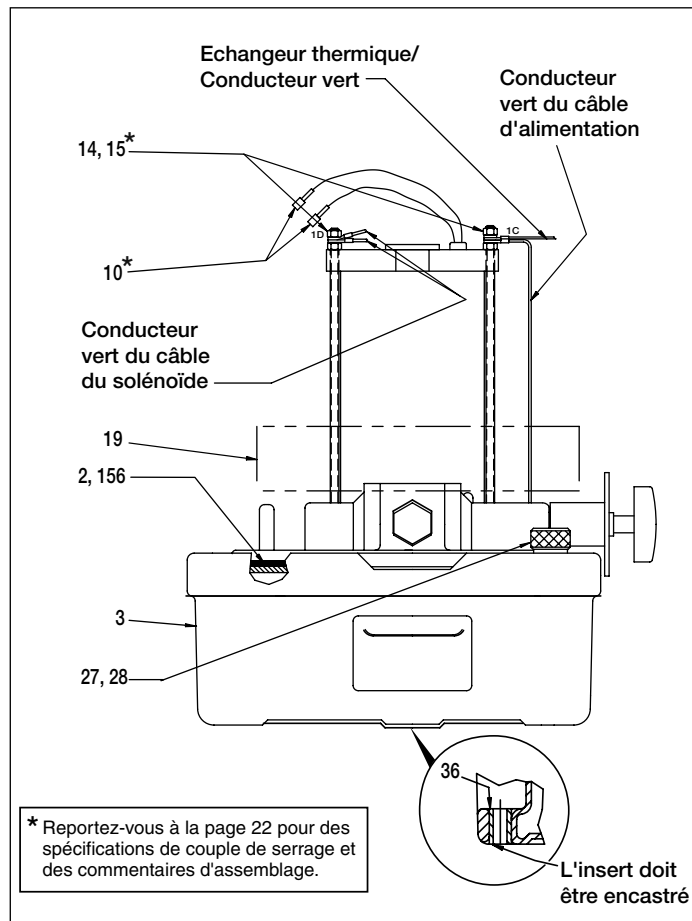

Figure 2, Vue avant de la pompe (Sans la tôle de protection)

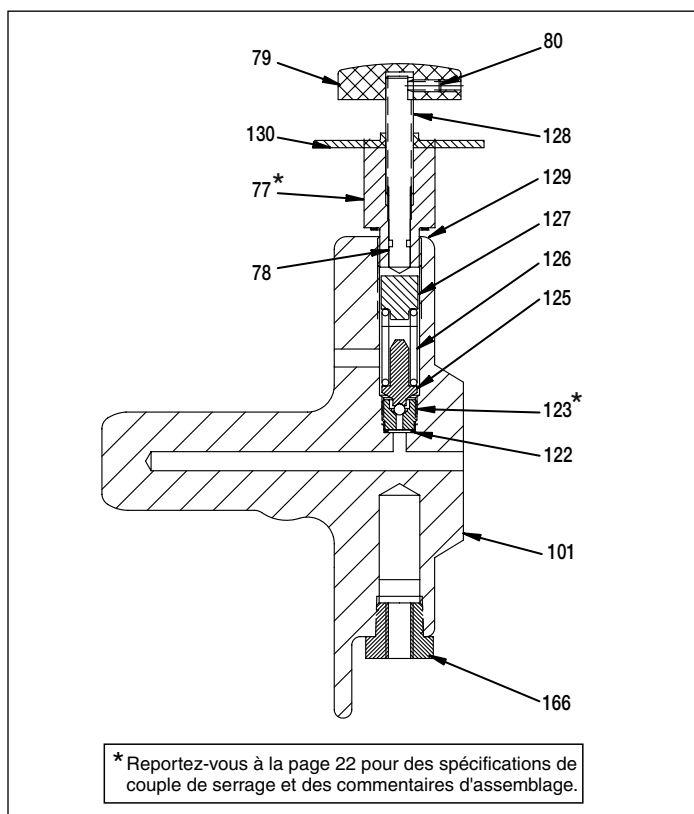

Figure 3, Valve de décharge

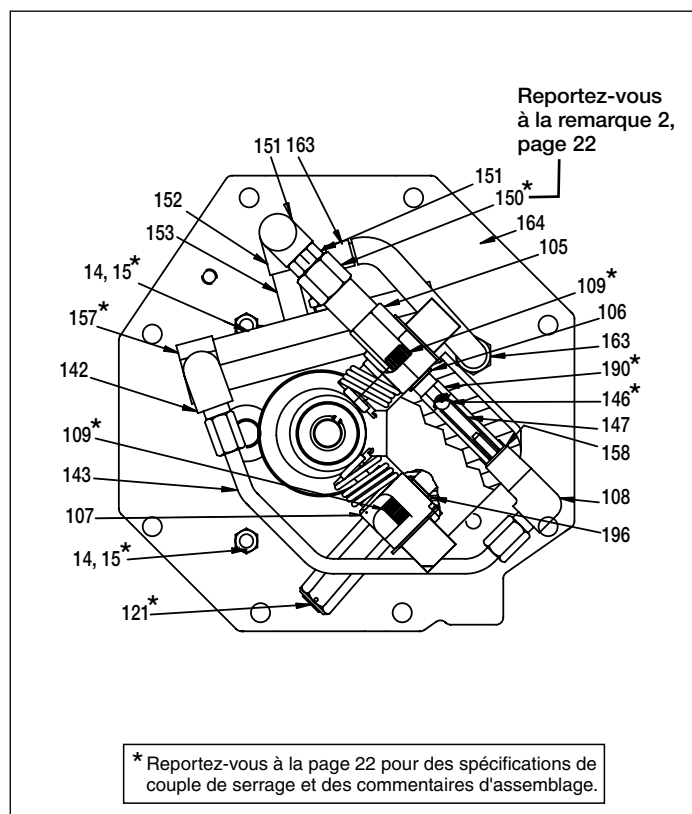

Figure 4, Vue de dessous de la pompe

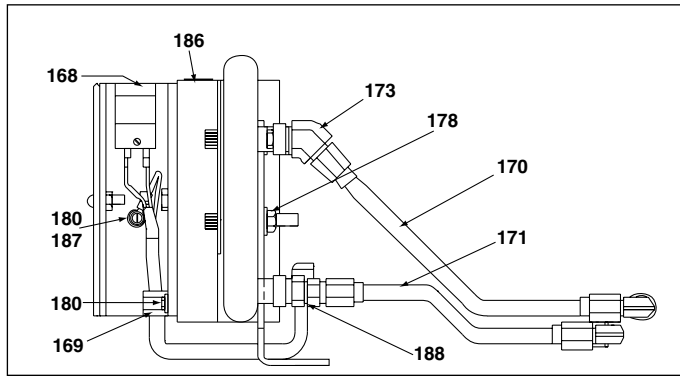

Figure 5, Échangeur de chaleur

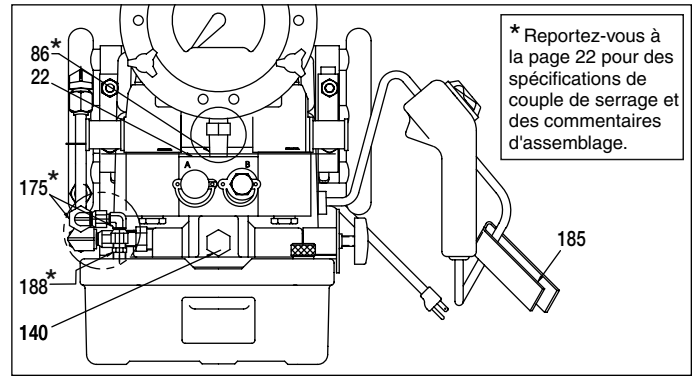

Figure 6, Vue avant de la pompe (assemblée)

Liste des pièces de rechange pour la Figure 1-6

Élément	Référence	Qté	Description
2	★ DA12088167SR	1	Joint (inclut l'article 156)
3	DA1910900SR	1	Ensemble du réservoir
10	DA3776006	2	Broche
14	DA15066	4	Rondelle de blocage
15	B1018121	4	Écrou hexagonal
17	CW261225	6	Oeilleton
18	F866028	6	Vis à métaux
19	CW259298	1	Chicane
22	DA5476900SR	1	Soupape à champignon 115V
	DA5477900SR	1	Soupape à champignon 220V
25	contacter Enerpac	1	Plaque signalétique
26	DC818003	4	Rivet pop
27	DA608024	1	Bouchon d'aération
28	★ B1906503	1	Joint torique
36	DA931225	2	Insert
42	DC3760900	1	Calibre
77	DA5775190	1	Vis de réglage
78	★ B1003503	1	Joint Torique
79	CB815381	1	Bouton
80	DC5714028	1	Vis de serrage
81	B1080066	3	Rondelle de blocage
82	B1326028	3	SHCS
83	DA7858147	3	Bouton
84	DC2926004	1	Bride
85	DC2290900	1	Kit Cadran
86	F100095	1	Raccord 45°
87	B1018121	3	Écrou hexagonal
101	DA12490840SR	1	Collecteur de pompes (inclut l'article 121)
102	CW179259	1	Moteur 115 VAC
	DC1415259	1	Moteur 220 VAC (50 Hz)
105	CW298950SR	1	53 Ensemble piston d'arrêt
106	★ B1007503	1	Joint torique
107	CW299950SR	1	24 Ensemble piston d'arrêt
108	★ B1012803	1	Joint torique
109	B1010028X	4	Vis
110	CW252107	1	Palier
114	CW301228	1	Engrenage moteur
115	★ B1097057	1	Goupille ressort
116	★ CW199107	1	Palier
117	CW251107	1	Palier
118	CW302107	1	Palier
119	CW303104	1	Arbre
121	DA5999900SR	1	Valve de décharge (reportez-vous à la Figure 4)
122	★ C846037	1	Joint
123	★ DA5771290	1	Siège
125	DC1316900SR	1	Assemblage de guidage à billes
126	★ DA3282110	1	Ressort de compression

★ Indique les articles inclus dans le kit de réparation PME10427K

Élément	Référence	Qté	Description
127	DA5772013	1	Guide de ressort
128	DA5773048	1	Vis de réglage
129	★ S1167	1	Rondelle
130	DA5774021	1	Écrou
140	R515245-2	1	Bouchon
142	B202291	1	Coude
143	DA7000268	1	Tube
144	★ CW467044	1	Bague de retenue
145	★ DA445107	2	Palier
146	★ B1007016	1	Bille
147	★ DA1564110	1	Ressort
149	DA5859028	4	Vis
150	DA1015950SR	1	Assemblage de valve de décharge
151	DA5849092	1	Raccord coudé
152	Y714291	1	Coude
153	★ C642395	1	Raccord
154	★ CU876028	3	Vis (10-24)
155	DA3585186	3	Entretoise
156	See item 2	1	Joint
157	★ DA9628900SR	1	Assemblage de la soupape d'allègement
158	DC834900SR	1	Assemblage du ressort de guidage
161	DA5879026	1	Autocollant d'avertissement
163	F100097-52	2	Coude mâle, 90°
164	DC1939268	1	Tubulure en nylon
165	F100097-33	1	Connecteur, mâle
166	CJ657032	1	Réducteur
168	DA9432471	1	Échangeur thermique 115V
	DA9572471	1	Échangeur thermique 220V
169	Y99017	1	Lanière
170	DA9511268	1	Tube
171	DA9512268	1	Tube
173	F100094102	1	Coude à 45°
174	F100094-5	1	Connector, Male
175	F100094-210	3	Coude
178	CBE1080120-2A	4	Écrou
180	CU876028	2	Vis
181	DA7567028	1	Vis
185	DA7570217	1	Sangle
186	DA9590026	1	Decal, Spartan
187	B1080066	1	Rondelle de blocage
188	CA945096	2	Connecteur
190	DA12352290	1	Siège de bille
196	★ C332291	1	Raccord
200	★ DC1947167	1	Joint
Balais de remplacement pour moteurs électriques			
- - -	DA9584380SR	1	Ensemble de balais pour modèles 115V
- - -	DA9585380SR	1	Ensemble de balais pour modèles 220V

* Reportez-vous à la page 22 pour des spécifications de couple de serrage et des commentaires d'assemblage.

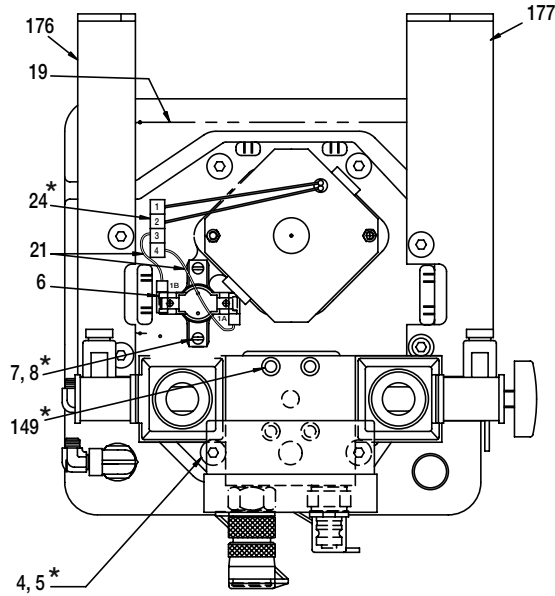

Figure 7, Vue de dessus de la pompe

Liste des pièces de rechange pour la Figure 7

Élément	Référence	Qté	Description
4	DA6954167	8	Joint
5	DC2038028	8	Vis
6	DA5135380	1	Thermostat
7	C701222	2	Rondelle
8	M642028	2	Vis
19	CW259298	1	Chicane
21	DC7969960	2	Câbles
24	DA11540380	1	Logement de goupille
149	DA5859028	4	Vis
176	DA9439111	1	Support droit
177	DA9438111	4	Support gauche

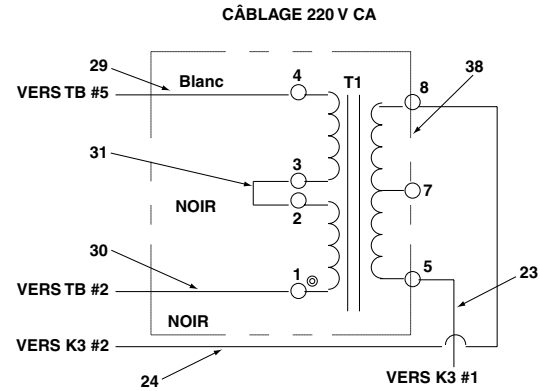
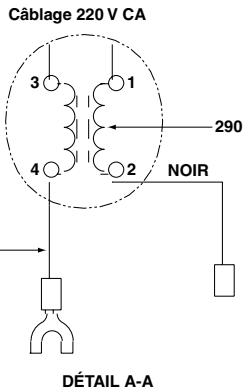
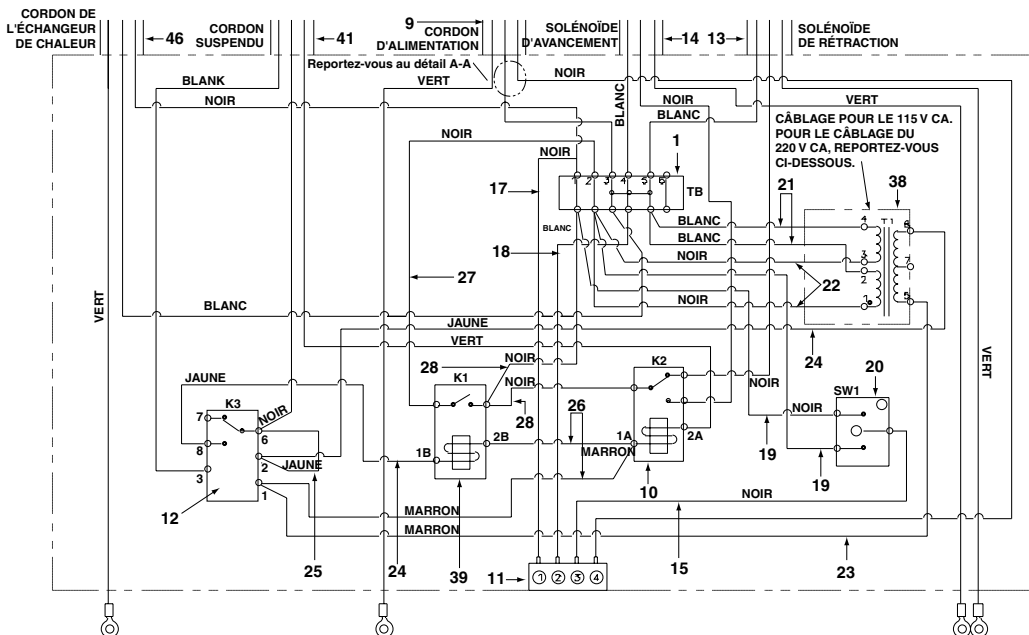

Figure 8, Schéma de câblage (Voir tableau de câblage de la pompe à la page suivante.)

Tableau de câblage de la pompe pour les modèles 115 VAC et 220 VAC (Voir Figure 8)							
Tension	Élément	Couleur	Raccordements électriques	Tension	Élément	Couleur	Raccordements électriques
Les deux	15	Noir	(article 11, terminal 3) vers (article 20, terminal 3A)	Les deux	26	Marron	(article 10, terminal 1A) vers (article 39, terminal 2B et article 12, terminal 1)
Les deux	17	Noir	(article 11, terminal 1) vers (article 1, terminal 1)	Les deux	27	Noir	(article 39, terminal COM) vers (article 1, terminal 2)
Les deux	18	Blanc	(article 11, terminal 2) vers (article 1, terminal 4)	Les deux	28	Noir	(article 39, terminal NO) vers (article 10, terminal COM et article 1, terminal 1)
Les deux	19	Noir	(article 20, terminal 3B) vers (article 1, terminal 1)	115 VAC 115 VAC 115 VAC	9	Noir Blanc Vert	connecter à l'article 11, terminal 4 connecter à l'article 1, terminal 3 connecter au moteur, terminal 1C
Les deux	19	Noir	(article 20, terminal 3C) vers (article 1, terminal 2)	220 VAC 220 VAC 220 VAC	9	Noir Blanc Vert	(article 290, terminal 1) (article 290, terminal 3) connecter au moteur, terminal 1C
115 VAC	21	Blanc	(article 1, terminal 5) vers (article 38, terminaux 2 et 4)	Les deux Les deux Les deux	13	Noir Blanc Vert	connecter à l'article 10, terminal NC connecter à l'article 1, terminal 5 connecter au moteur, terminal 1D
115 VAC	22	Noir	(article 1, terminal 2) vers (article 38, terminaux 1 et 3)	Les deux Les deux Les deux	14	Noir Blanc Green	connecter à l'article 10, NO terminal connecter à l'article 1, terminal 4 connecter au moteur, terminal 1D
220 VAC	29	Blanc	(article 1, terminal 5) vers (article 38, terminal 4)	Les deux Les deux Les deux	41	Noir Blanc Vert	connecter à l'article 12, terminal 6 connecter à l'article 12, terminal 3 connecter à l'article 10, terminal 2A
220 VAC	30	Noir	(article 1, terminal 2) vers (article 38, terminal 1)	220 VAC	290	Noir	connecter à l'article 11, terminal 4
220 VAC	31	Noir	(article 38, terminal 2) vers (article 38, terminal 3)	220 VAC	292	Blanc	(article 290, terminal 4) vers (article 1, terminal 3)
Les deux	23	Marron	(article 12, terminal 1) vers (article 38, terminal 5)				
Les deux	24	Jaune	(article 12, terminal 2) vers (article 38, terminal 8)				
Les deux	24	Jaune	(article 12, terminal 8) vers (article 39, terminal 1B)				
Les deux	25	Jaune	(article 12, terminal 6) vers (article 12, terminal 2)				

Note: Reportez-vous à la liste des pièces de rechange page 18 pour la description des articles supplémentaires représentés sur la figure 8.

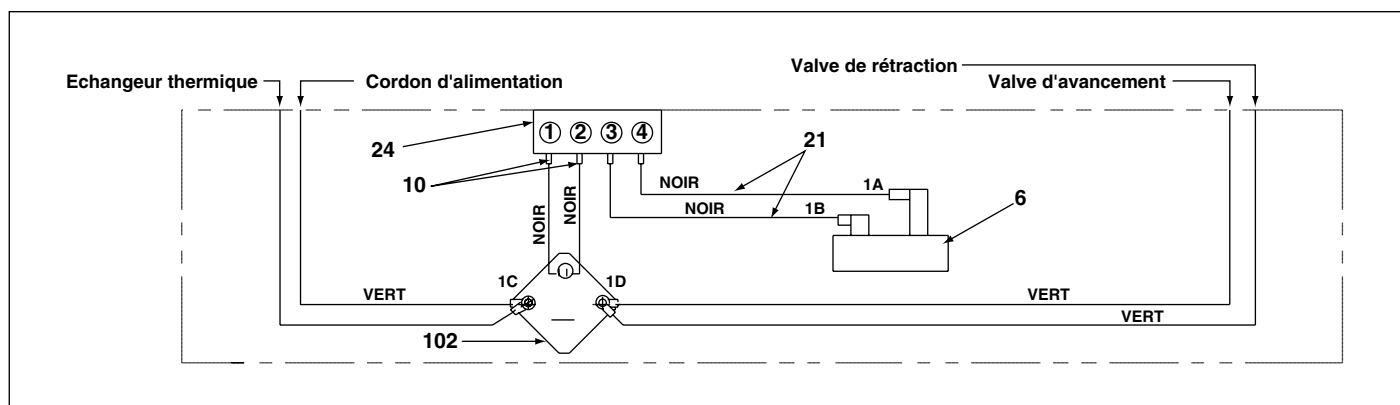

Figure 9, Schéma de câblage

Liste des pièces de rechange pour la Figure 9							
Élément	Référence	Qté	Description	Élément	Référence	Qté	Description
6	DA5135380	1	Thermostat	24	DA11540380	1	Logement de goupille
10	DA3776006	2	Broche	102	CW179259	1	Moteur 115 VAC
21	DA3712900SR	2	Câbles		DC1415259	1	Moteur 220 VAC (50 Hz)

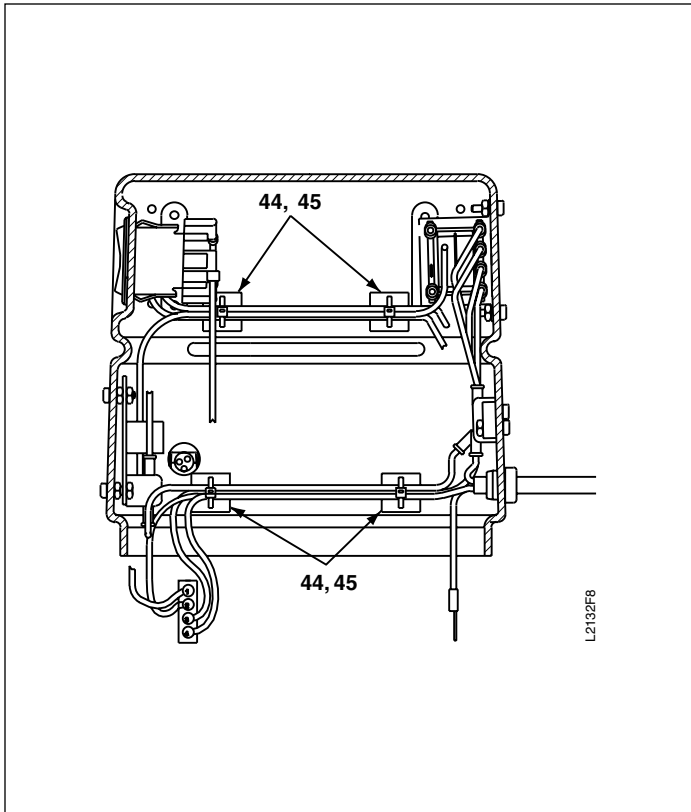

Figure 10, Câblage de la tôle de protection - derrière le moteur

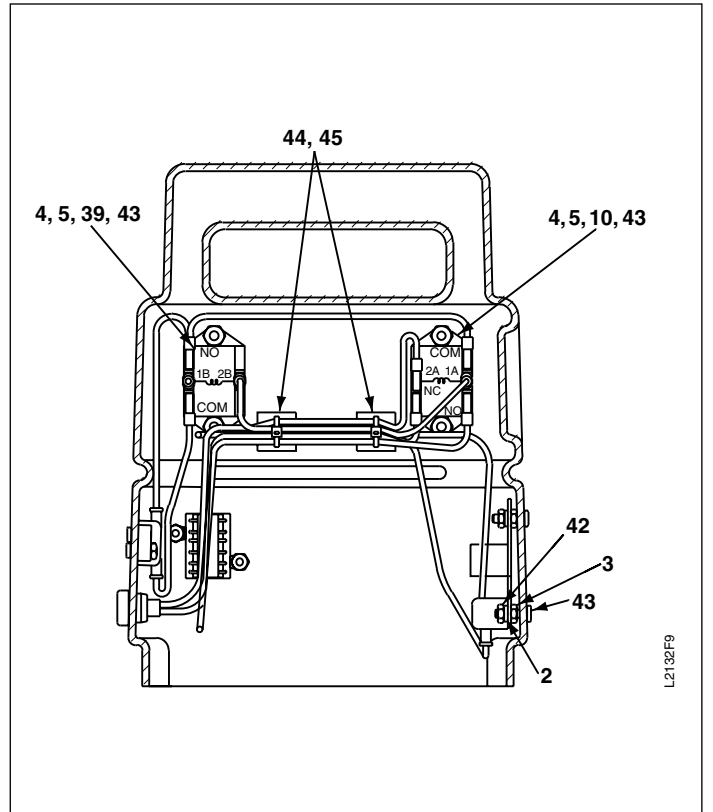

Figure 11, Câblage de la tôle de protection - devant le moteur

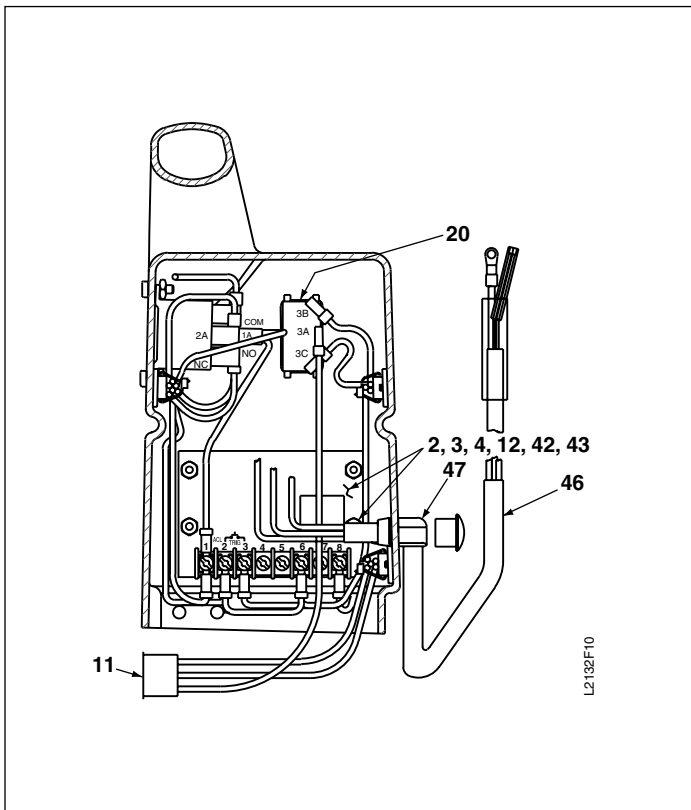

Figure 12, Câblage de la tôle de protection - côté gauche du moteur

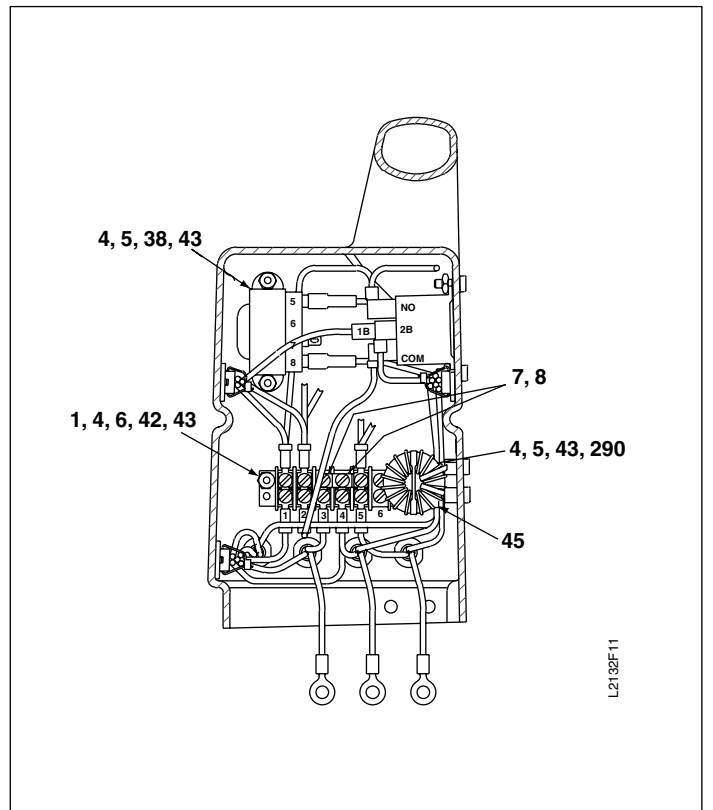

Figure 13, Câblage de la tôle de protection - côté droit du moteur

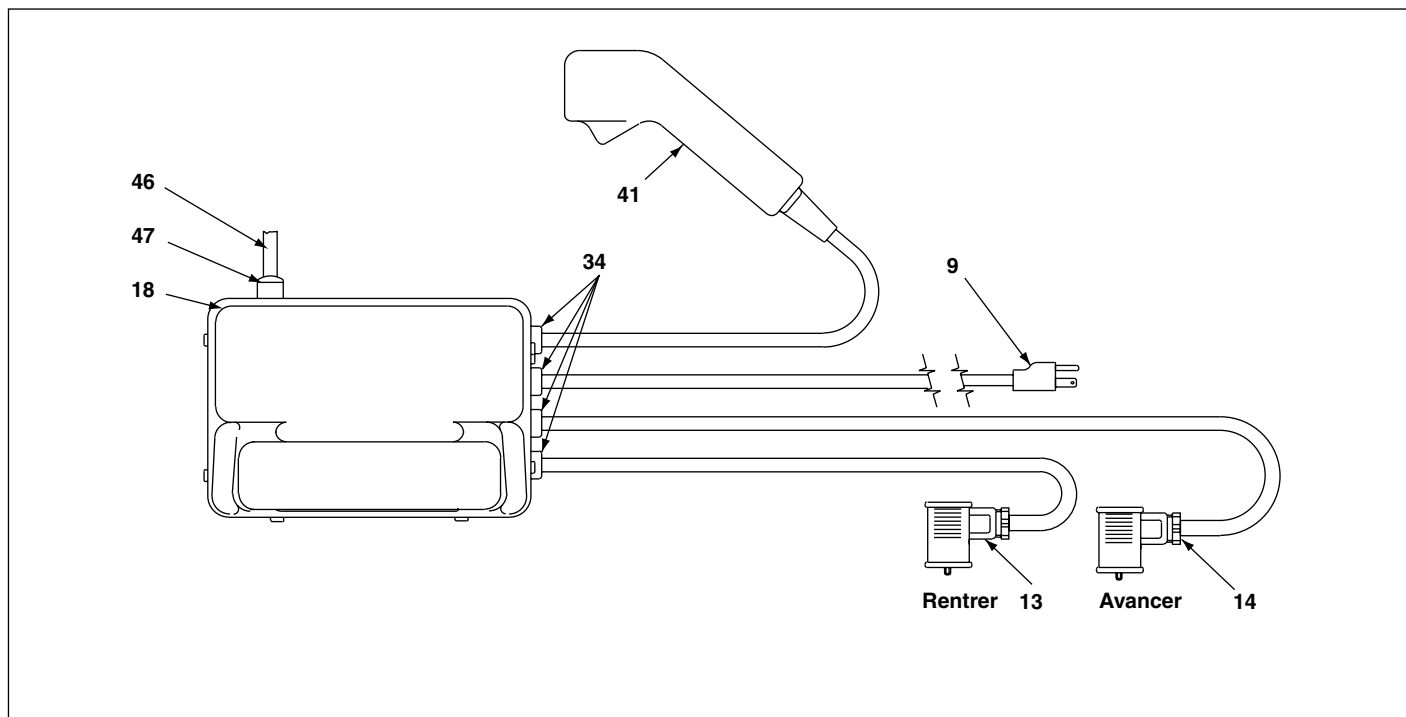

Figure 14, Vue de dessus - cordons et câbles

Liste des pièces de rechange pour la Figure 10-14							
Élément	Référence	Qté	Description	Élément	Référence	Qté	Description
1	DA5884199	1	Barrette de raccordement	14	DA5917900SR	1	Câble de solénoïde
2	CH890108	4	Rondelle	18	DA5921900SR	1	Câbles
3	DA5909021	4	Écrou en nylon #6-32	20	E1500002	1	Interrupteur
4	BC1310728	12	Vis (115 V)	34	CR759291	4	Protection de cordon
	BC1310728	14	Vis (220V)	38	DA5875380	1	Transformateur
5	F75021	6	Ecrou de blocage, #6-32 (115V)	39	E1300008	1	Relais
	F75021	8	Ecrou de blocage, #6-32 (220V)	41	DA5799900SR	1	Pupitre mobile (Fig. 15)
6	DA5801199	1	Barrette de raccordement avec marqueur	42	B1013121	6	Écrou hexagonal
7	DA5803199	2	Cavalier terminal	43	DA5974098	12	Protection pour vis (115V)
8	DA5802199	1	Couvercle de bornier		DA5974098	14	Protection pour vis (220V)
9	DA5913900SR	1	Cordon d'alimentation 115 VAC	44	EHC3901075	6	Lanière pour câbles, Autocollant
	DA3728900SR	1	Cordon d'alimentation 220 VAC	45	DA3131217	7	Lien métallique
10	DA5581980	1	Relais	46	DC9520900	1	Cordon de l'échangeur de chaleur
11	DA11539380	1	Connecteur à douille	47	DA9521380	1	Protection
12	DA9284980	1	Relais de temporisation	290	DC374900	1	Montage d'étrangleur (220 V seulement)
13	DA5915900SR	1	Câble de solénoïde				

★ Note: Pour le remplacement de l'ensemble complet de la tôle de protection, commander le Kit de réparation DC7940900SR (115V) ou DC7941900SR (220V).

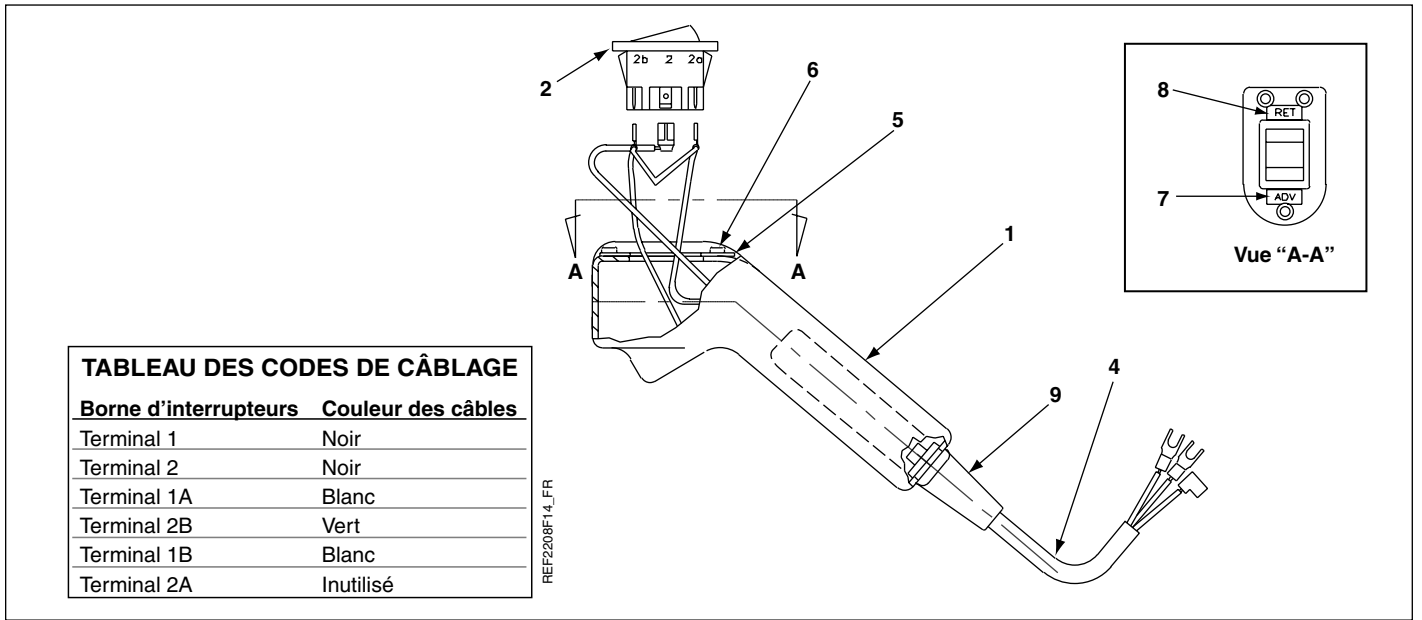

Figure 15, Pupitre mobile

Liste des pièces de rechange pour la Figure 15							
Élément	Part Number	Qté	Description	Élément	Part Number	Qté	Description
1	★DA1323190	1	Pupitre mobile complet.	7	★DA1686026	1	Autocollant
2	★E1500001	1	Interrupteur à bascule	8	★DA2804026	1	Autocollant
4	★DA5912900SR	1	Cordon	9	★DA1568007	1	Protection de Cordon
5	★DA1415101	1	Plaque de montage	185	★DA7570217	1	Sangle (Fig. 6)
6	★DC818003	3	Rivet pop				

★ Le Kit de réparation DC5799900SR inclue le pupitre mobile complet (tous les composants listés ci-dessus).

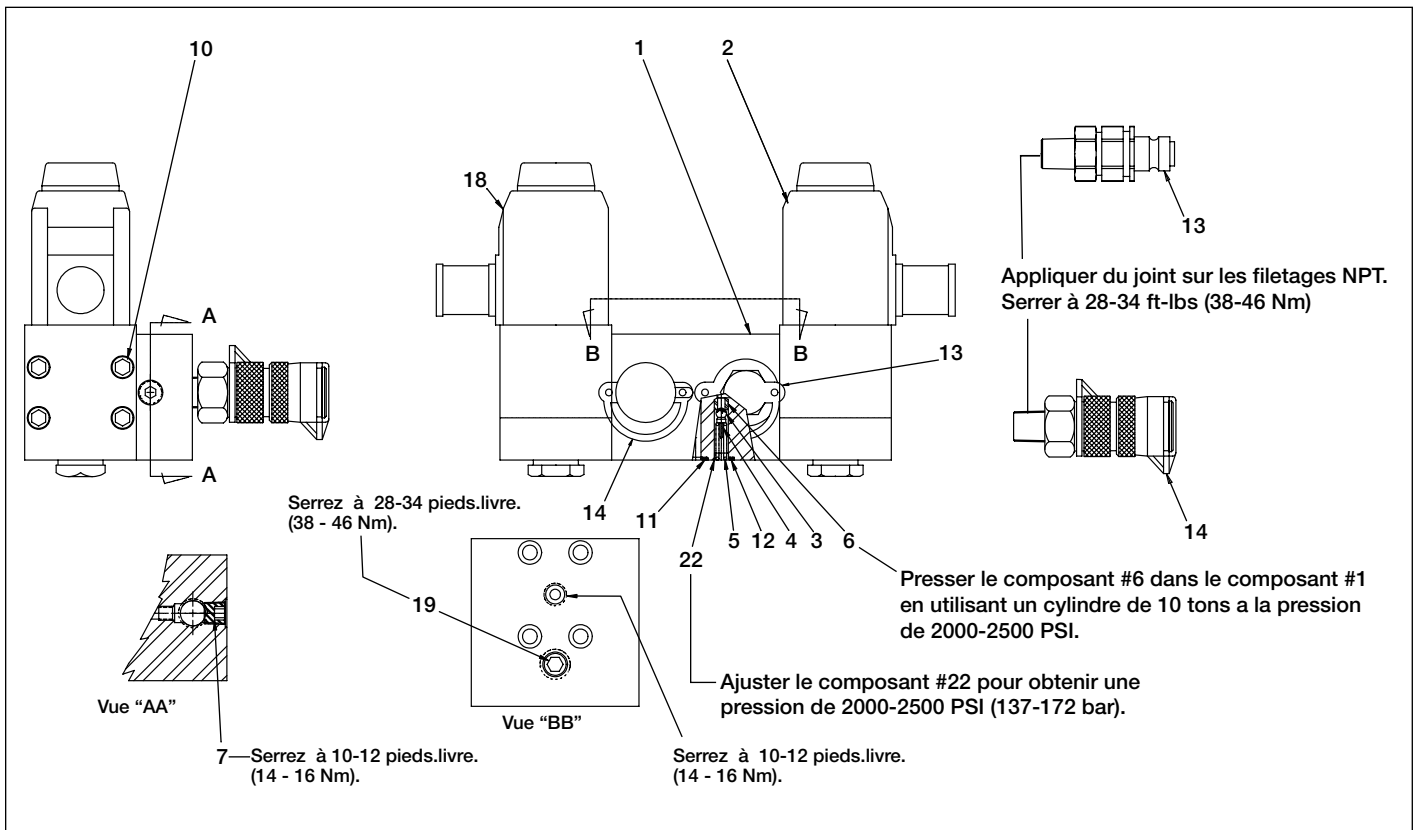

Figure 16, Soupape à champignon

Liste des pièces de rechange pour la Figure 16

Élément	Part Number	Qté	Description	Élément	Part Number	Qté	Description
1	▲★ DC4920190	1	Corps	11	▲★ B1011803	1	Joint torique
2	VSG2310P	1	Soupape à champignon 115V (Fig. 17)	12	▲★ B1231503	2	Joint torique
	VSG3510P	1	Soupape à champignon 220V (Fig. 17)	13	DC6432034	1	Raccord mâle
3	▲★ B1005016	1	Bille 3/16"	14	DC6431034	1	Raccord femelle
4	▲★ F522570	1	Capuchon de bille	18	DC847900SR	1	Soupape à champignon 115V (Fig. 18)
5	▲★ A8238110	1	Ressort de compression		DC848900SR	1	Soupape à champignon 220V (Fig. 18)
6	▲★ A8015290	1	Siège	19	▲ A1008245	1	Bouchon de tuyau - 3/4
7	▲★ A1007245	2	Bouchon de tuyau - 1/8	22	▲★ DC5840048	1	Vis creuse de blocage
10	▲ B1022028	8	Vis				

★ Indique les articles inclus dans le kit de réparation DA5476900K.

(Le kit de réparation DA5476900K est inclus dans le kit de réparation de la pompe PME10427K.)

▲ Indique les articles inclus dans le kit de réparation DA5850190SR.

Note: Le Corps DC4920190 dans le kit de réparation a maintenant des ports 1/4 NPTF.

Assurez-vous d'avoir des raccords avec filetage 1/4 NPTF ou commandez les raccords DC6432034 and DC6431034.

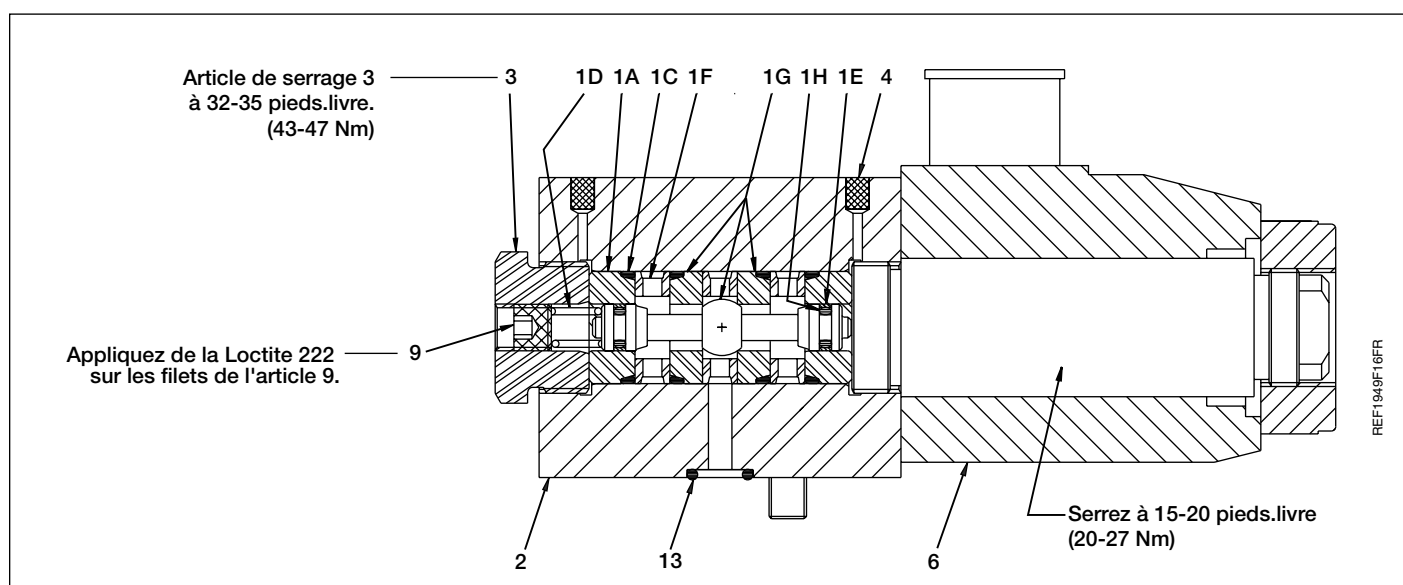

Figure 17, Ensemble soupape à champignon

Liste des pièces de rechange pour la Figure 17

Élément	Part Number	Qté	Description	Élément	Part Number	Qté	Description
1	★ DA5792949SR	1	Empilement de soupapes (incl. comp. 1A-1H)	2	DA4393190	1	Corps de valve
1A	DA3697039	2	Protection	3	DA5421009	1	Bouchon de valve
1C	† B1016803	4	Joint torique	4	† DA4390118	2	Filtre
1D	† DA5422110	1	Ressort de compression	6	DA4405900	1	Solénoïde (115V)
1E	† CH279044	2	Glyd. Ressort		DA5714900	1	Solénoïde (220V)
1F	DA3698290	3	Entretoise de siège	9	PA1417027	1	Vis de serrage
1G	DC862949	1	Jeux de clapets	13	★† B1011803	3	Joint torique
1H	† B1002503	2	Joint torique				

★ Indique les articles inclus dans le kit de réparation DA5476900K.

† Indique les articles inclus dans le kit de réparation DA5792949SR.

(Le kit de réparation DA5476900K est inclus dans le kit de réparation de la pompe PME10427K.)

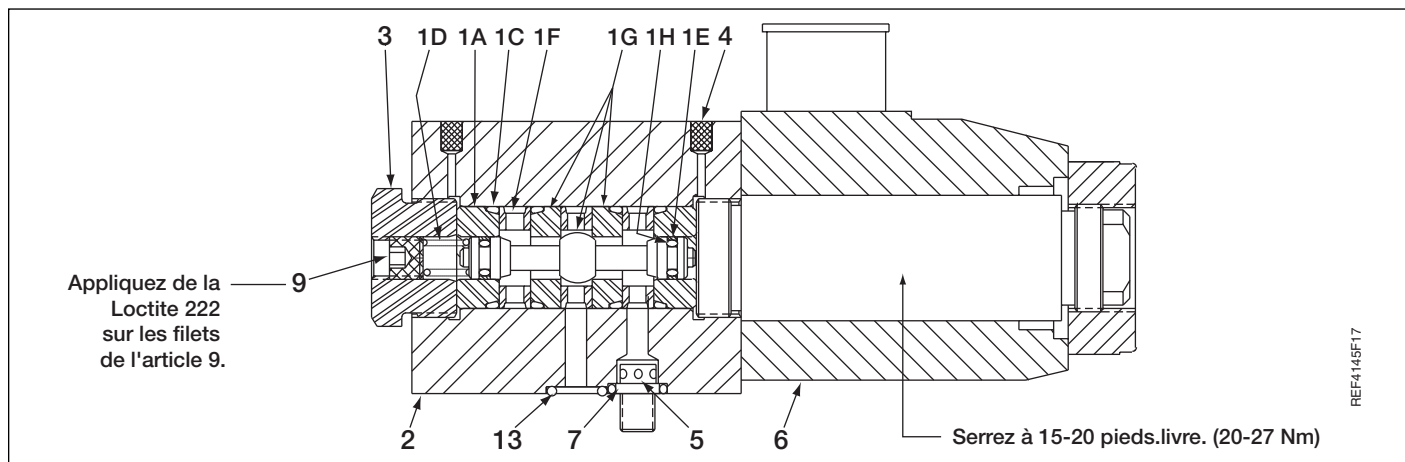

Figure 18, Ensemble soupape à champignon

Liste des pièces de rechange pour la Figure 18

Élément	Part Number	Qté	Description	Élément	Part Number	Qté	Description
1	★ DA5792949SR	1	Empilement de soupapes (incl. comp. 1A-1H)	3	DA5421009	1	Bouchon de valve
1A	★ DA3697039	2	Protection	4	★† DA4390118	2	Filtre
1C	★† B1016803	4	Joint torique	5	DC844661SR	1	Clapet anti-retour
1D	★† DA5422110	1	Ressort de compression	6	DA4405900	1	Solénoïde (115V)
1E	★† CM279044	2	Glyd. Ressort		DA5714900	1	Solénoïde (220V)
1F	★ DA3698290	3	Entretoise de siège	7	★† B1006503	1	Joint torique
1G	★ DC862949	1	Jeux de clapets	9	PA1417027	1	Vis de serrage
1H	★† B1002503	2	Joint torique	13	★† B1011803	3	Joint torique
2	DC846190	1	Corps de valve				

★ Indique les articles inclus dans le kit de réparation DA5476900K.

Le kit de réparation DA5476900K inclue (2) kit de réparation DA5792949K.

Le kit de réparation DA5476900K est inclus dans le kit de réparation de la pompe PME10427K.

† Indique les articles inclus dans le kit de réparation DA5792949SR.

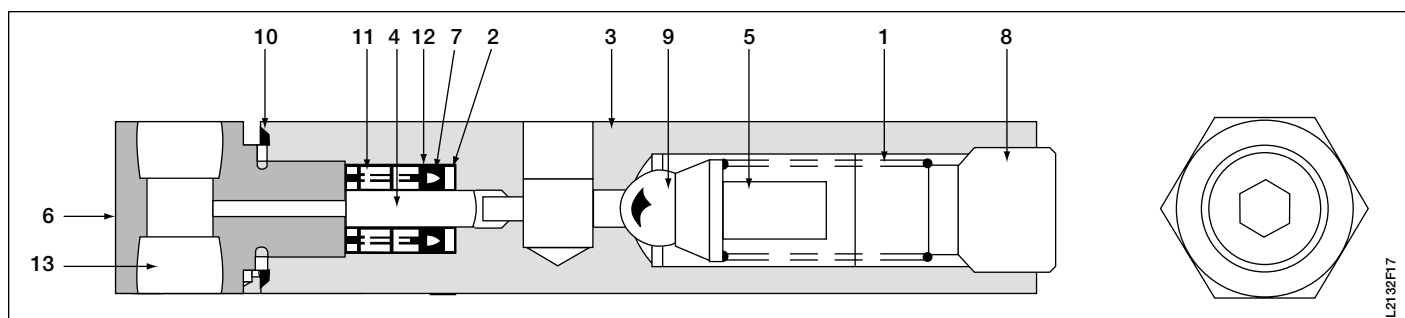

Figure 19, Soupape d'allégement

Liste des pièces de rechange pour la Figure 19

Élément	Part Number	Qté	Description	Élément	Part Number	Qté	Description
1	★ DA3282110	1	Ressort de compression	8	C641087	1	Vis
2	★ SJ100016	1	Rondelle de secours	9	★ B1009016	1	Bille
3	DA9628900SR	1	Valve (Complète)	10	★ S15167	1	Joint
4	C622339	1	Piston	11	★ S4375	1	Ressort
5	DA3284160	1	Cage de retenue des billes	12	★ B1024562	1	Bague de secours en cuir
6	DA3285038	1	Adaptateur	13	A1007245	1	Bouchon de tuyau
7	★ C639053	1	Coupelle en U				

★ Indique les articles inclus dans le kit de réparation DA3281900K.

(Le kit de réparation DA3281900K est inclus dans le kit de réparation de la pompe PME10427K).

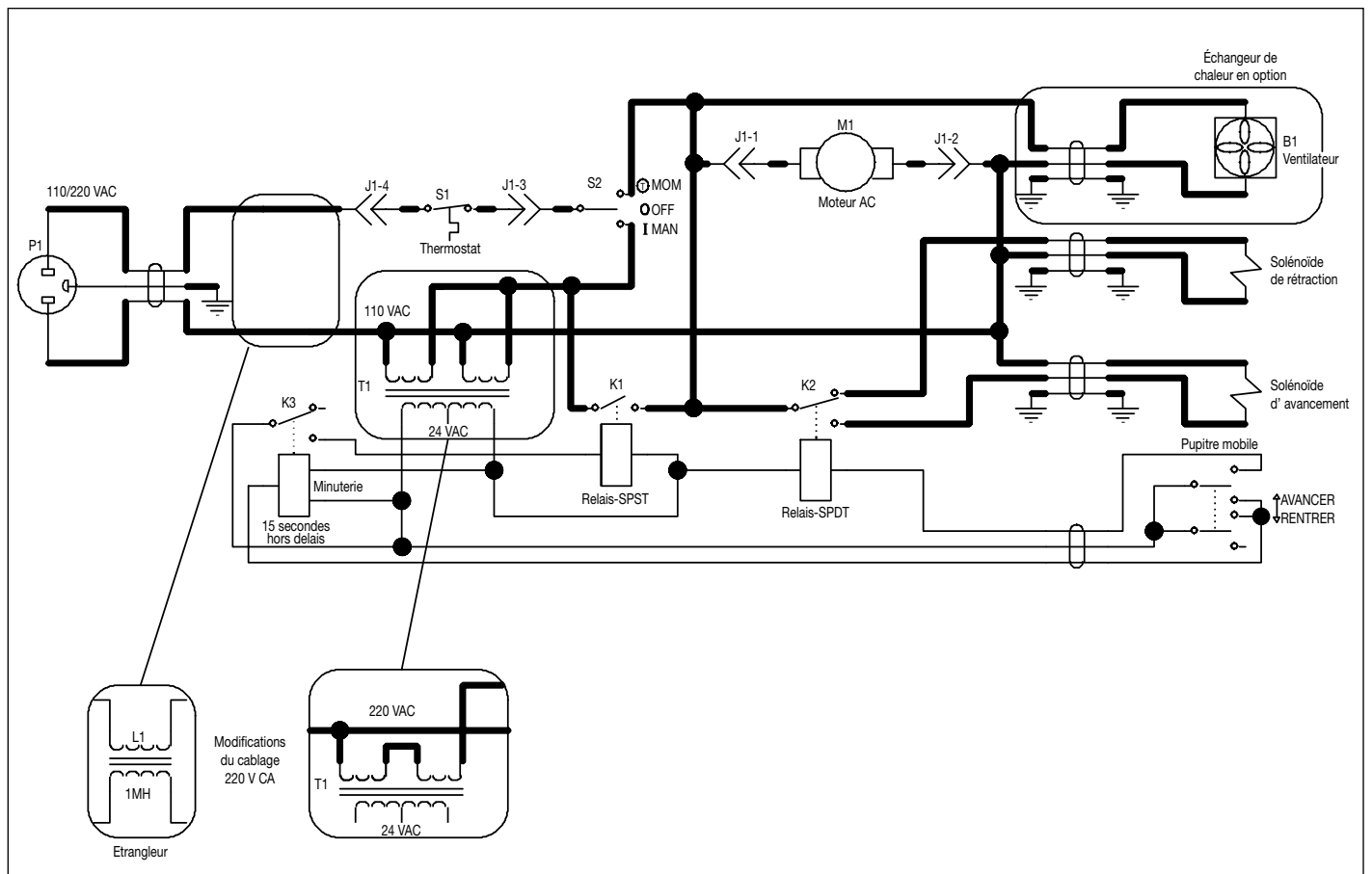

Figure 20, Schéma électrique

Figure	Élément	Spécifications de serrage et remarques d'assemblage
1	18	Appliquer une goutte de Loctite #242 sur les filets. Serrage de 12 à 18 po-livre (1,4 à 2,0 Nm)
1	42	Serrage de 24 à 30 po-livre (32 à 40 Nm).
1	82	Serrage de 18 à 25 po-livre (2,0 à 2,8 Nm). Maintenir le composant 87 contre le calibre pendant l'assemblage de l'article 82.
1	Remarque 1	Installez le palier, article 117, encastré de 0.010" (2,54 mm) par rapport à la surface.
2	10	Couper les cables à 9-10 po (228-254 mm) avant d'attacher les broches (article 10). Insérer ensuite dans l'article 24.
2	15	Serrage de 20 à 25 po-livre (2,2 à 2,8 Nm).
3	77	Serrage de 15 à 20 po-livre (20 à 27 Nm).
3	123	Serrage de 15 à 16 po-livre (20,0 à 21,7 Nm) lubrifié.
4	15	Serrage de 31 à 33 po-livre (3,5 à 3,7 Nm).
4	109	Serrage de 14 à 16 pied-livre (19,0 à 21,7 Nm).
4	121	Serrage de 16 à 19 pied-livre (21,7 à 25,8 Nm).
4	146	Le siège doit être estampé.
4	150	Le réglage de la valve doit se situer entre 10 et 30 psi (0,7 à 2,0 bar).
4	157	Le réglage de la valve de décharge doit se situer entre 625 et 825 psi (43,2 à 56,8 bar).
4	190	Assembler en appliquant de la Loctite 609.
4	Remarque 2	Vérifiez les filets avoir établi la pression.
6	86	Serrage de 44 à 53 po-livre (60 à 71 Nm). La connection ne doit pas fuir à la pression de travail.
6	175, 188	Assembler les connecteurs du refroidisseur d'huile et serrer à 10-12 pied-livre. Utiliser du joint en Teflon sur les filetages des tuyaux. Utiliser de la Loctite 242 pour les écrous de tuyaux et serrer à 18-22 pied-livre.
7	149	Serrage de 8 à 10 po-livre (10,8 to 13,5 Nm).
7	5	Serrage de 59 à 52 pied-livre (66 à 70 Nm).
7	8	Serrage de 8 à 12 po-livre (0,9 à 1,35 Nm).
7	24	Brancher au connecteur de la tôle de protection.

Enerpac Worldwide Locations

Africa

ENERPAC Middle East FZE
Office 423, JAFZA 15
P.O. Box 18004
Jebel Ali, Dubai
United Arab Emirates
Tel: +971 (0)4 8872686
Fax: +971 (0)4 8872687

Australia, New Zealand

Actuant Australia Ltd.
Block V Unit 3
Regents Park Estate
391 Park Road
Regents Park NSW 2143
(P.O. Box 261) Australia
Tel: +61 297 438 988
Fax: +61 297 438 648

Brazil

Power Packer do Brasil Ltda.
Rua dos Inocentes, 587
04764-050 - Sao Paulo (SP)
Tel: +55 11 5687 2211
Fax: +55 11 5686 5583
Toll Free in Brazil:
Tel: 0800 891 5770
vendasbrasil@enerpac.com

Canada

Actuant Canada Corporation
6615 Ordan Drive, Unit 14-15
Mississauga, Ontario L5T 1X2
Tel: +1 905 564 5749
Fax: +1 905 564 0305
Toll Free:
Tel: +1 800 268 4987
Fax: +1 800 461 2456
Technical Inquiries:
techservices@enerpac.com

China

Actuant China Ltd.
1F, 269 Fute N. Road
Waigaoqiao Free Trade Zone
Pudong New District
Shanghai, 200 131 China
Tel: +86 21 5866 9099
Fax: +86 21 5866 7156

◆ e-mail: info@enerpac.com

Actuant China Ltd. (Beijing)

709B Diyang Building
Xin No. 2
Dong San Huan North Rd.
Beijing City
100028 China
Tel: +86 10 845 36166
Fax: +86 10 845 36220

Central and Eastern Europe, Greece

ENERPAC GmbH
P.O. Box 300113
D-40401 Düsseldorf
Willstätterstrasse13
D-40549 Düsseldorf
Germany
Tel: +49 211 471 490
Fax: +49 211 471 49 28

France, Switzerland francophone

ACTUANT - ENERPAC
France S.A., ZA de Courtaboeuf
32, avenue de la Baltique
91140 Villebon / Yvette
France
Tel: +33 1 60 13 68 68
Fax: +33 1 69 20 37 50

Germany, Austria

and Switzerland
ENERPAC GmbH
P.O. Box 300113
D-40401 Düsseldorf
Willstätterstrasse13
D-40549 Düsseldorf
Germany
Tel: +49 211 471 490
Fax: +49 211 471 49 28

India

ENERPAC Hydraulics
(India) Pvt. Ltd.
Office No. 9,10 & 11,
Plot No. 56, Monarch Plaza,
Sector 11, C.B.D. Belapur
Navi Mumbai 400614, India
Tel: +91 22 2756 6090
Tel: +91 22 2756 6091
Fax: +91 22 2756 6095

Italy

ENERPAC S.p.A.
Via Canova 4
20094 Corsico (Milano)
Tel: +39 02 4861 111
Fax: +39 02 4860 1288

Japan

Applied Power Japan Ltd.
Besshochou 85-7
Saitama-shi, Kita-ku,
Saitama 331-0821
Japan
Tel: +81 48 662 4911
Fax: +81 48 662 4955

Middle East, Turkey and Caspian Sea

ENERPAC Middle East FZE
Office 423, JAFZA 15
P.O. Box 18004
Jebel Ali, Dubai
United Arab Emirates
Tel: +971 (0)4 8872686
Fax: +971 (0)4 8872687

Russia and CIS

(excl. Caspian Sea Countries)
Actuant LLC
Admiral Makarov Street 8
125212 Moscow, Russia
Tel: +7-495-9809091
Fax: +7-495-9809092

Singapore

Actuant Asia Pte. Ltd.
37C, Benoi Road Pioneer Lot,
Singapore 627796
Tel: +65 68 63 0611
Fax: +65 64 84 5669
Toll Free: +1800 363 7722
Technical Inquiries:
techsupport@enerpac.com.sg

◆ internet: www.enerpac.com

South Korea

Actuant Korea Ltd.
3Ba 717,
Shihwa Industrial Complex
Jungwang-Dong, Shihung-Shi, Kyunggi-Do
Republic of Korea 429-450
Tel: +82 31 434 4506
Fax: +82 31 434 4507

Spain and Portugal

ENERPAC
Avda. Los Frailes, 40 – Nave C & D
Pol. Ind. Los Frailesancho De Arriba
(Madrid) Spain
Tel: +34 91 661 11 25
Fax: +34 91 661 47 89

The Netherlands, Belgium, Luxembourg, Sweden, Denmark, Norway, Finland and Baltic States

ENERPAC B.V.
Galvanistraat 115, 6716 AE Ede
P.O. Box 8097, 6710 AB Ede
The Netherlands
Tel: +31 318 535 911
Fax: +31 318 525 613
+31 318 535 848

Technical Inquiries Europe:
techsupport.europe@enerpac.com

United Kingdom, Ireland

Enerpac Ltd
Bentley Road South
Darlaston, West Midlands
WS10 8LQ, United Kingdom
Tel: +44 (0)121 50 50 787
Fax: +44 (0)121 50 50 799

USA, Latin America and Caribbean

ENERPAC
P.O. Box 3241
6100 N. Baker Road
Milwaukee, WI 53209 USA
Tel: +1 262 781 6600
Fax: +1 262 783 9562

User inquiries:
+1 800 433 2766

Inquiries/orders:
+1 800 558 0530

Technical Inquiries:
techservices@enerpac.com

All Enerpac products are guaranteed against defects in workmanship and materials for as long as you own them.
For your nearest authorized Enerpac Service Center, visit us at www.enerpac.com