

L2078 Rev. K 01/23

PUD1100B, PUD1101B: For Date Codes Beginning with the Letter “H”
PUD1100E, PUD1101E: For Date Codes Beginning with the Letter “G”

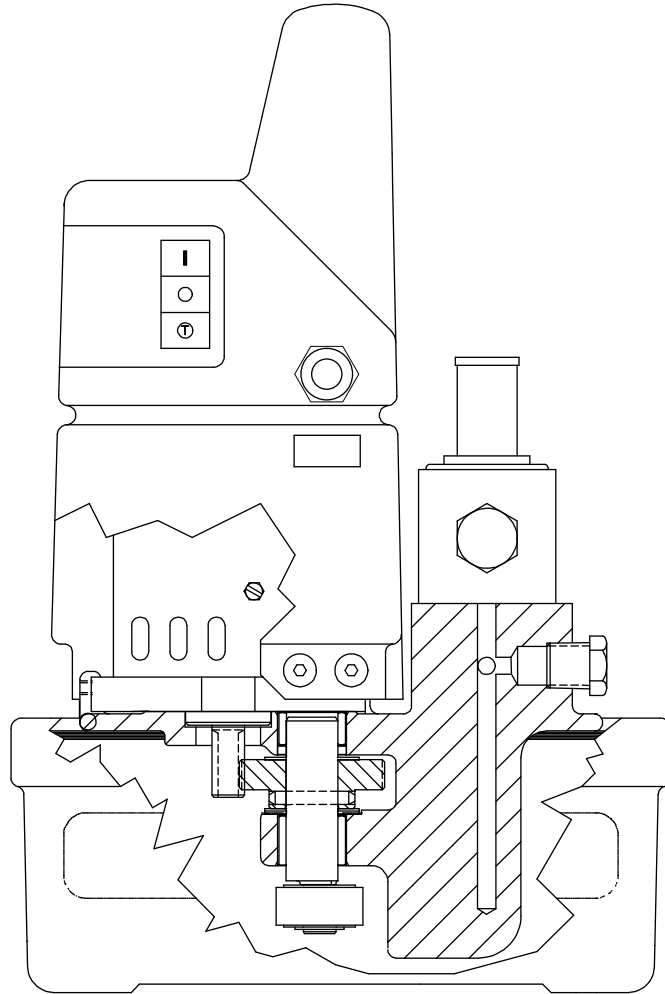

Contents:

Figure 1 - Pump Side View	2	Figure 9 - Shroud Wiring-Left of Motor	5
Figure 2 - Pump Front View (shroud removed).....	2	Figure 10 - Shroud Wiring-Right of Motor.....	5
Figure 3 - Relief Valve.....	2	Figure 11 - Top View-Cord and Cables	6
Figure 4 - Pump Bottom View	2	Figure 12 - Pendant Assembly	7
Figure 5 - Pump Front View (assembled)	3	Figure 13 - Poppet Valve Assembly	8
Figure 6 - Pump Top View	4	Figure 14 - Electrical Schematic, 115V Models	8
Figure 7 - Shroud Wiring-Behind Motor	5	Figure 15 - Electrical Schematic, 230V Models.....	9
Figure 8 - Shroud Wiring-Front of Motor	5		

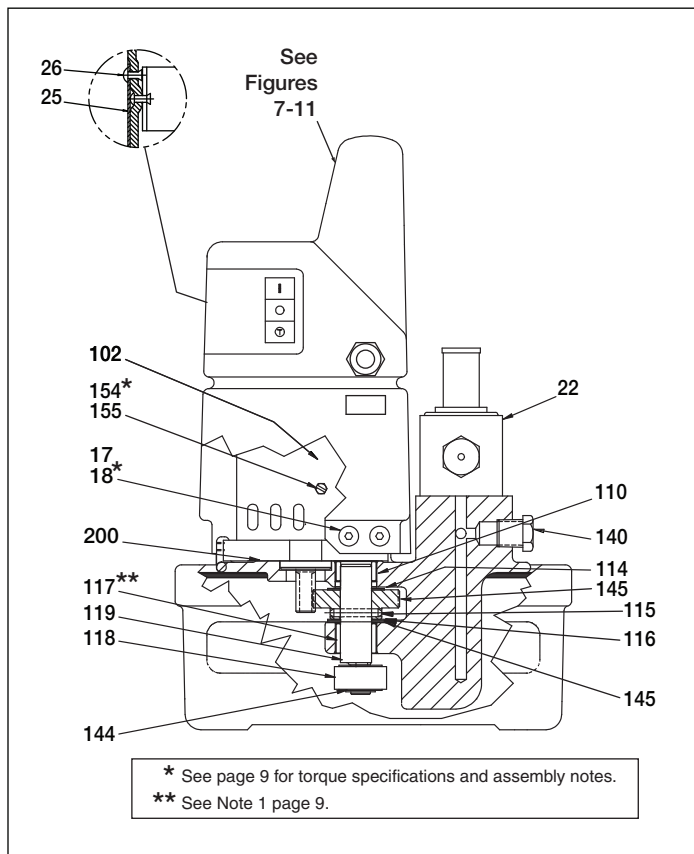

Figure 1, Pump Side View

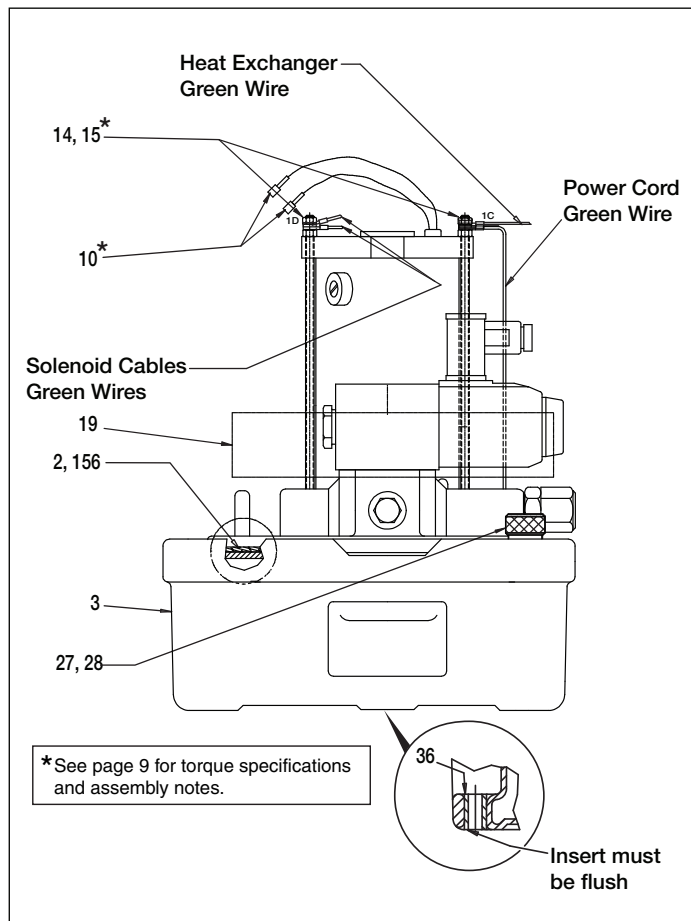

Figure 2, Pump Front View (shroud removed)

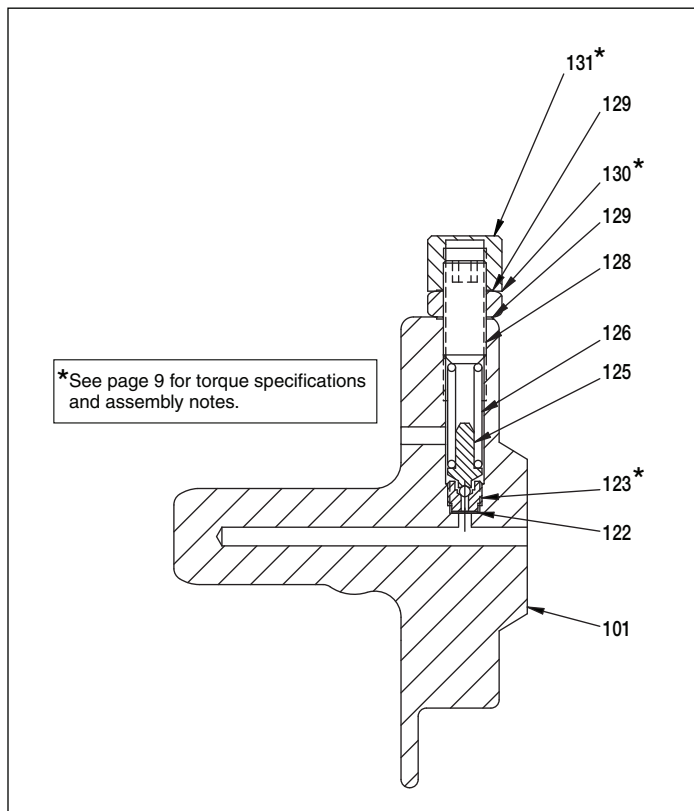

Figure 3, Relief Valve

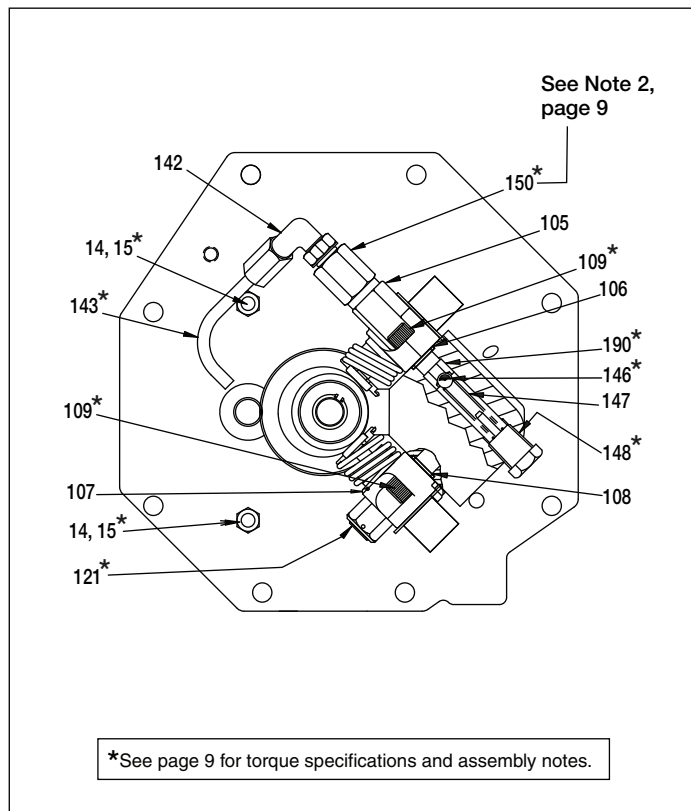

Figure 4, Pump Bottom View

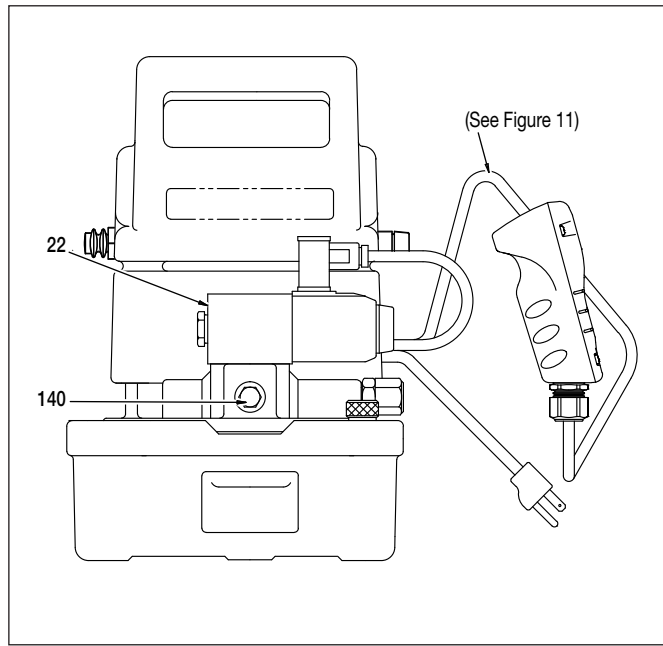

Figure 5, Pump Front View (assembled)

Repair Parts List for Figures 1 through 5

Item	Part Number	Qty.	Description
2	H DA12088167SR	1	Gasket (Includes item 156)
3	DA1910900SR	1	Reservoir Assembly. 0.5 Gal.
	DA4780900SR		Reservoir Assembly. 1.0 Gal.
10	DA3776006	2	Pin
14	DA15066	4	Lock Washer
15	B1018121	4	Hex Nut
17	CW261225	6	Eyelet
18	F866028	6	Machine Screw
19	CW259298	1	Baffle
22	VSG2310P	1	115V Poppet Valve Assy
	VSG3510P	1	230V Poppet Valve Assy
25	Contact Enerpac	1	Nameplate
26	DC818003	4	Pop Rivet
27	DA608024	1	Vent Plug
28	H B1906503	1	O-Ring
36	DA931225	2	Insert
101	DA12490840SR	1	Pump Manifold (includes # 121)
102	CW179259	1	115 VAC Motor
	DC1415259	1	230 VAC Motor (50 Hz)
105	DD1449051SR	1	Piston Block Assembly, 14mm
106	H B1007503	1	O-Ring
107	DD1450051SR	1	Piston Block Assembly, 6mm
108	H B1012803	1	O-Ring
109	B1010028X	4	Screw
110	CW252107	1	Bearing
114	CW301228	1	Driven Gear
115	H B1097057	1	Spring Pin
116	H CW199107	1	Bearing
117	CW251107	1	Bearing

☐ Included in Repair Kit PUD1100BK

Item	Part Number	Qty.	Description
118	CW302107	1	Bearing
119	CW303104	1	Shaft
121	DA5999900SR	1	Relief Valve (see Figure 4)
122	H C846037	1	Gasket
123	H DA5771290	1	Seat
125	DC1316900SR	1	Ball Guide Assembly
126	H A109164	1	Compression Spring
128	DA252028	1	Adjusting Screw
129	H S1167	1	Gasket
130	CW306055	1	Lock Nut
131	CW307055	1	Cap Nut
140	R515245-2	1	Plug
142	DA1011096	1	Elbow
143	DA261268	1	Tube
144	H CW467044	1	Retaining Ring
145	H DA445107	2	Bearing
146	H B1007016	1	Ball
147	H DA1564110	1	Spring
148	DC433950	1	Plug Assembly
149	B1020028	4	Cap Screw
150	DA610900SR	1	Relief Valve Assembly
154	H CU876028	3	Screw (10-24)
155	DA3585186	3	Spacer
156	See item 2	1	Gasket
190	DA12352290	1	Ball Seat
200	H DC1947167	1	Gasket

Replacement Brushes for Electric Motor

---	DA9655380	1	Brush Set for 115V Models
---	DA9656380	1	Brush Set for 230V Models

* See page 9 for torque specifications and assembly notes.

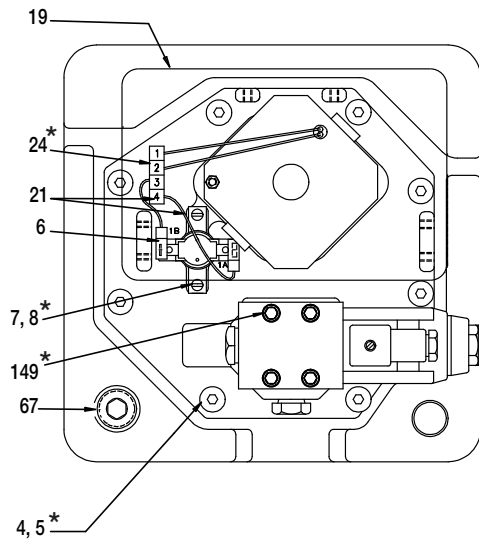

Figure 6, Pump Top View

Repair Parts List for Figure 6

Item	Part Number	Qty.	Description
4	DA6954167	8	Gasket
5	DC2038028	8	Screw
6	E1100004	1	Thermostat, 115V
	DC8401372	1	Thermostat, 230V
7	C701222	2	Washer
8	M642028	2	Screw
19	CW259298	1	Baffle
21	DC7969960	2	Wire Assembly
24	DA11540380	1	Pin Housing
67	A1009245	2	Plug
149	DD1074028	4	Cap Screw

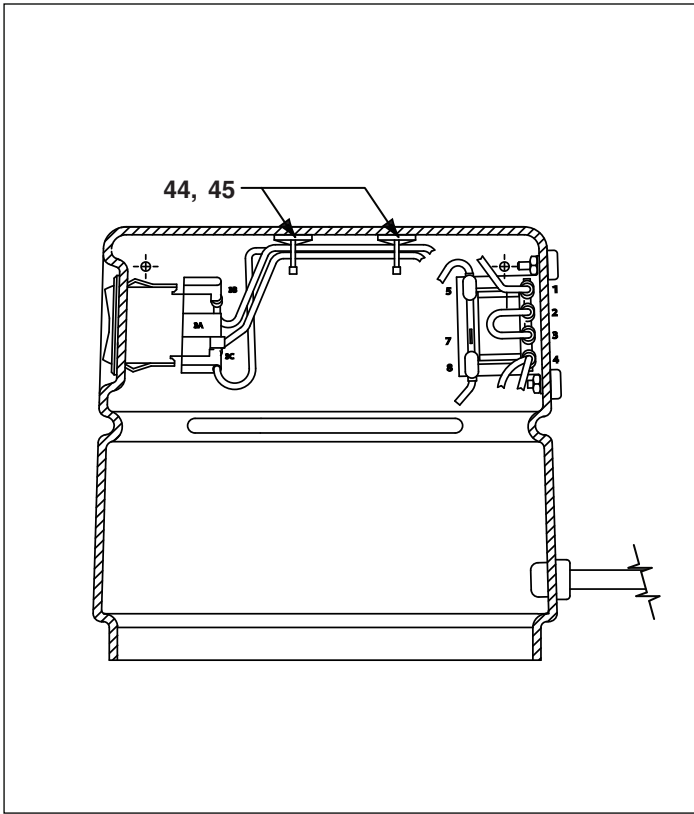

Figure 7, Shroud Wiring - Behind Motor

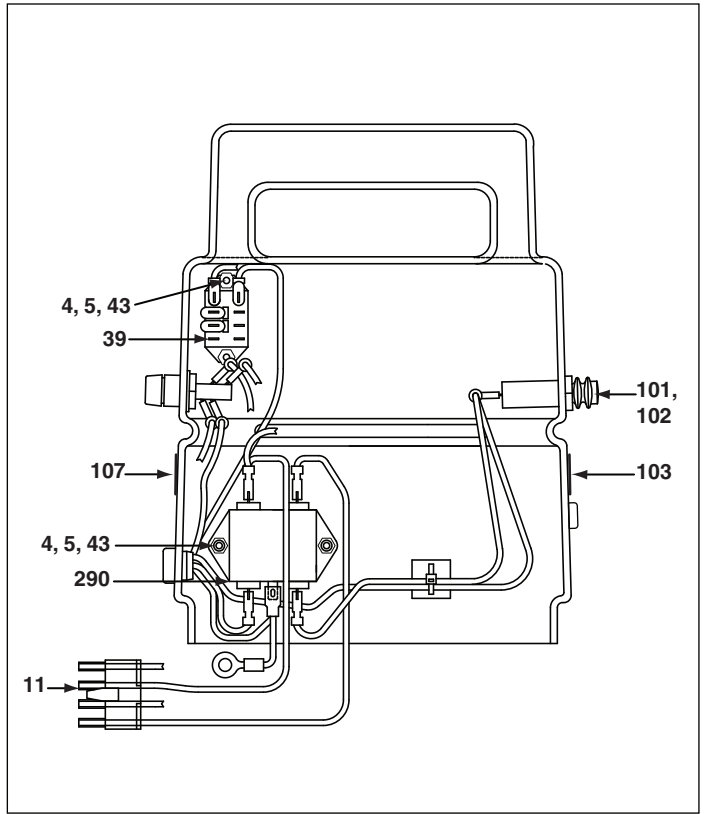

Figure 8, Shroud Wiring - Front of Motor

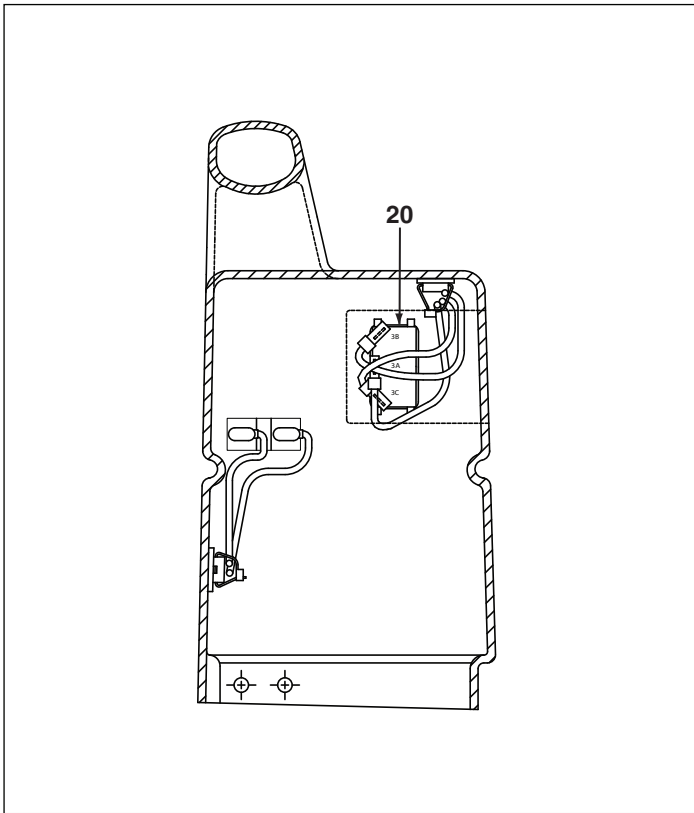

Figure 9, Shroud Wiring - Left of Motor

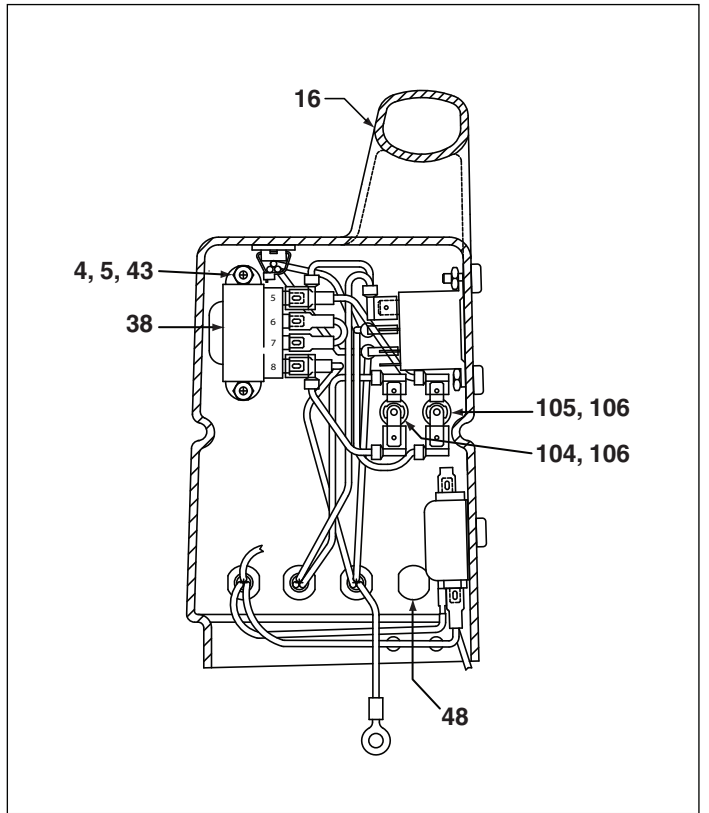

Figure 10, Shroud Wiring - Right of Motor

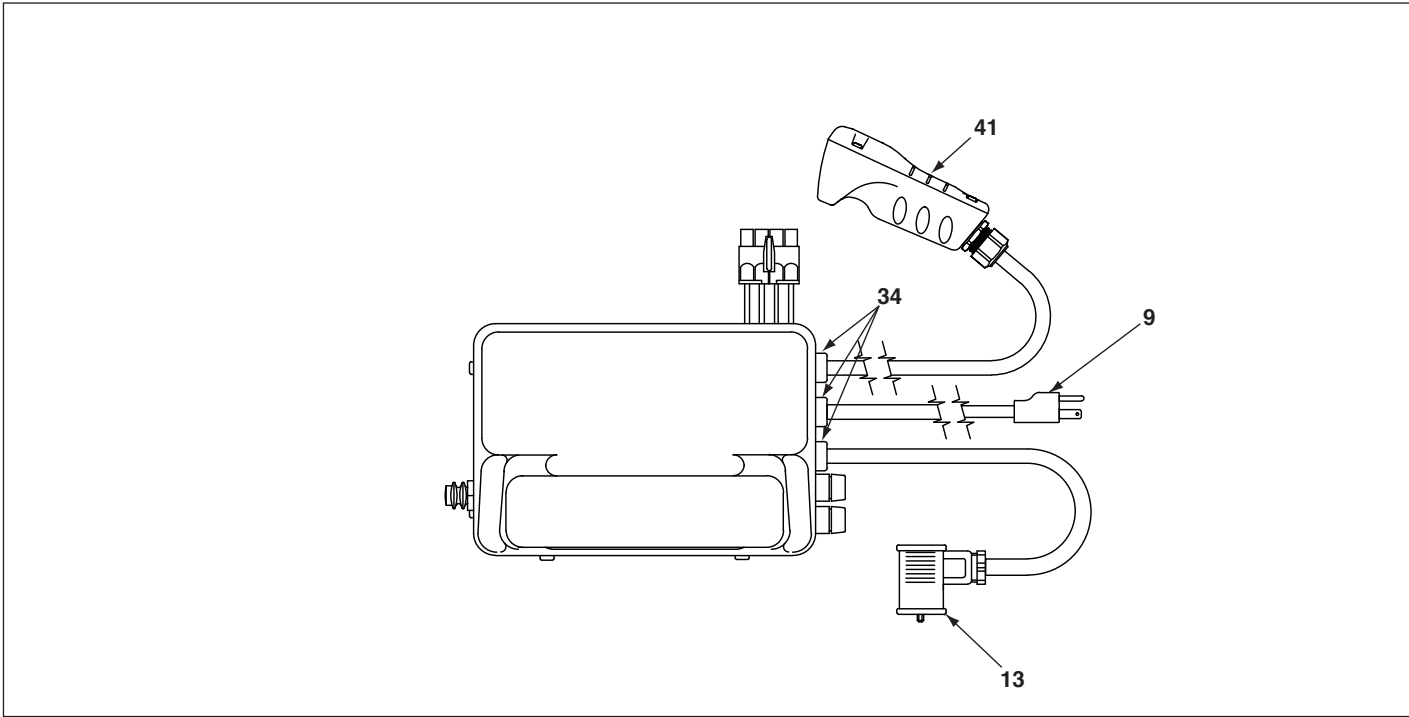

Figure 11, Top View, Cord and Cables

Repair Parts List for Figures 7 through 11

Item	Part Number	Qty.	Description	Item	Part Number	Qty.	Description
4	BC1310728	4	Screw (115V)	43	DA5974098	4	Screw Cover (115V)
	BC1310728	6	Screw (230V)		DA5974098	6	Screw Cover (230V)
5	F75021	4	Lock Nut #6-32 (115V)	44	EHC3901075	3	Tie Down, Self Adhesive
	F75021	6	Lock Nut #6-32 (230V)	45	DA3131217	4	Cable Tie
9	DC7954960SR	1	Power Cord, 115V	101	DC8366380	1	Circuit Breaker (115V)
	DD5840960SR	1	Power Cord, 230V		DC8367380	1	Circuit Breaker (230V)
11	DA11539380	1	Receptacle	102	DC8200380	1	Circuit Breaker Reset Cap
13	DC7911960SR	1	Solenoid Cable	103	DC8237023	1	Circuit Breaker Decal
	DC10037098	1	Shroud (115V)	104	DC8371378	1	Secondary Fuse, 300mA
16	DC10036098	1	Shroud (230V)	105	DC8370378	1	Primary Fuse, 62mA (115V)
	E1500002	1	Switch		DC8400378	1	Primary Fuse, 40mA (230V)
34	CR759291	3	Cord Bushing	106	DC8372378	2	Fuse Holder
38	DA5875380	1	Transformer	107	DC7891026	1	Fuse Decal
39	DD2668380	1	Relay (115V)	290	DC8365380	1	EMI Filter (230V only)
	DC8280980	1	Relay (230V)				
41	DD2686900SR	1	Pendant Assy (115V)				
	DD1048900SR	1	Pendant Assy (230V)				

Note: For replacement shroud assembly, order Repair Kit DC7944900SR (115V) or DC7945900SR (230V).

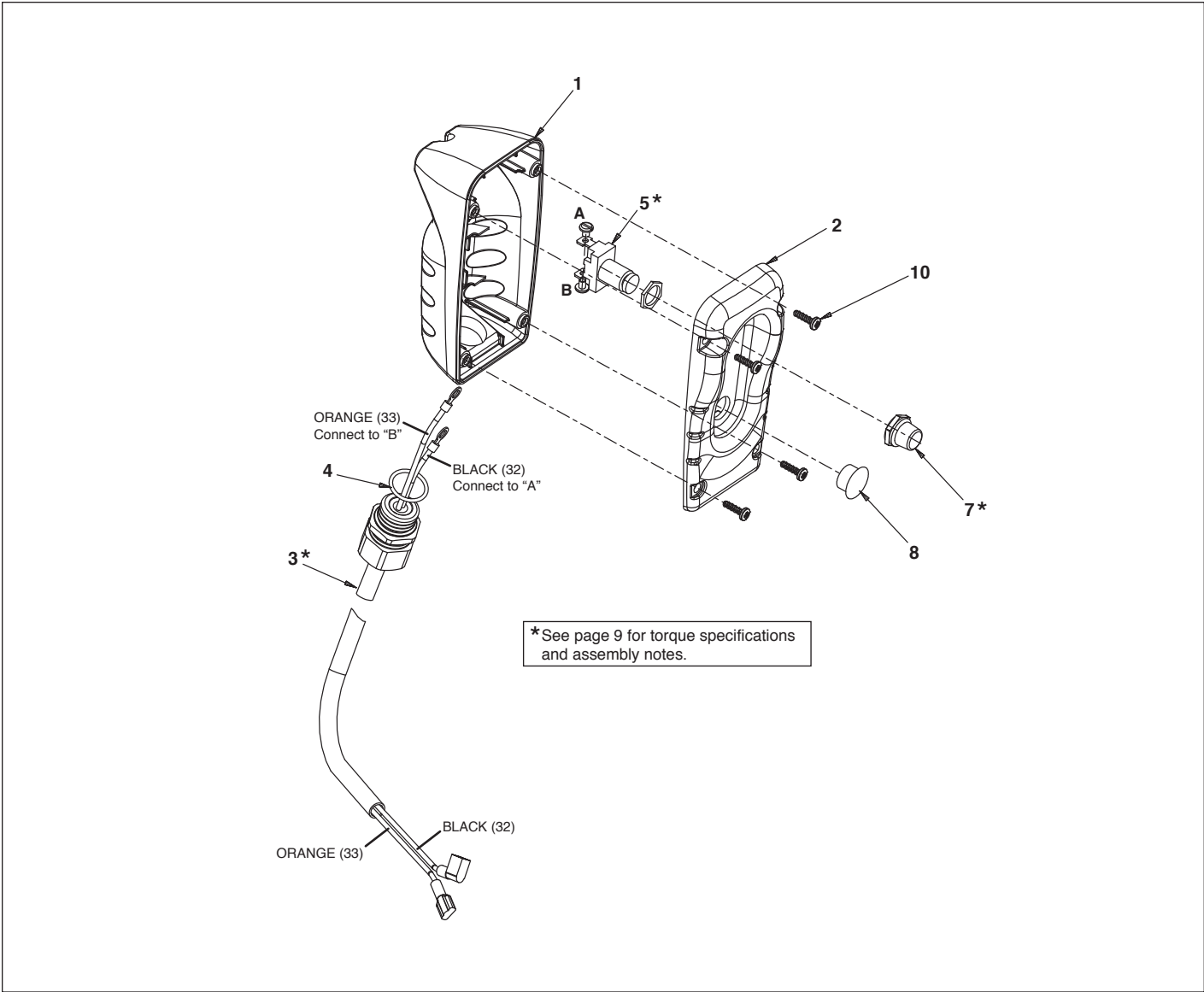

Figure 12, Pendant Assembly

Repair Parts List for Figure 12							
Item	Part Number	Qty.	Description	Item	Part Number	Qty.	Description
1	DC9425424	1	Assembly, Lower Pendant	5	DC8282379	1	Switch, Push Button
2	DC8122424	1	Assembly, Upper Pendant	7	DC8284379	1	Boot, Push Button
3	DD2684960	1	Pendant Cord (115V Models)	8	DC8228009	1	Dome Plug, 1/2"
	DD1053960	1	Pendant Cord (230V Models)	10	DC9428008	4	Screw, Hi-Lo #8 x1/2"
4	B1223503	1	O-Ring				

Complete replacement pendant assembly (includes all items shown in Fig. 12):

- 115V Models: order Repair Kit DD2686900SR.
- 230V Models: order Repair Kit DD1048900SR.

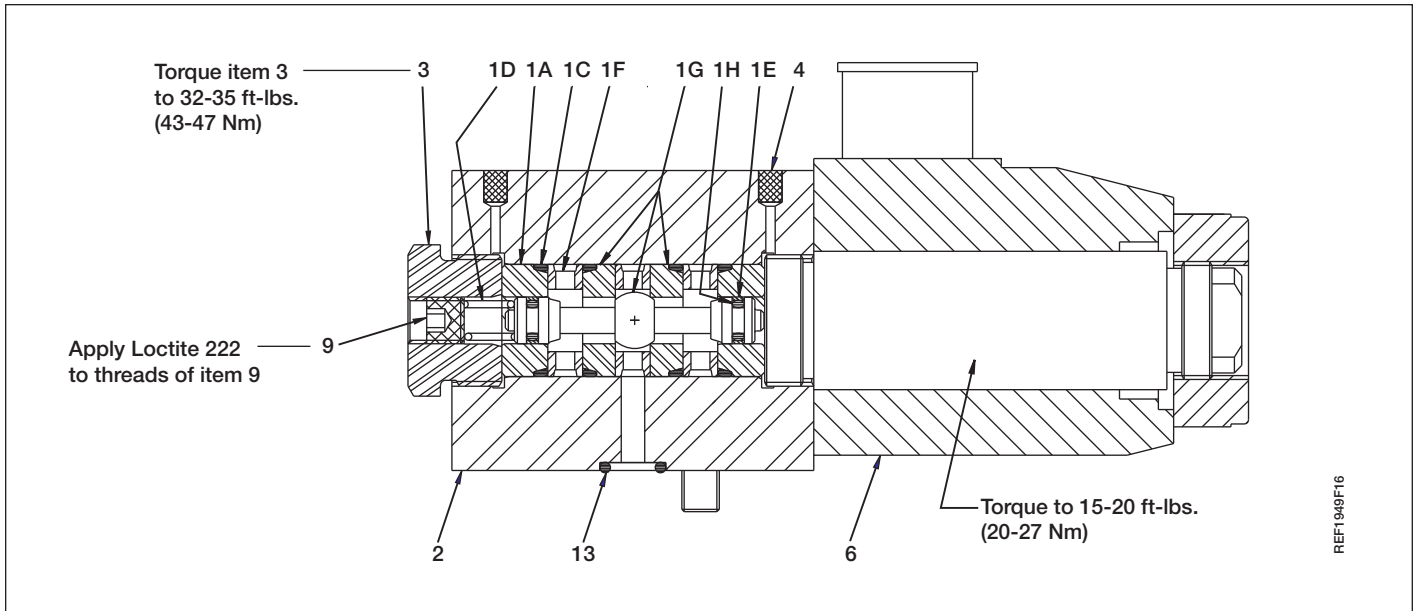

Figure 13, Poppet Valve Assembly

Repair Parts List for Figure 13							
Item	Part Number	Qty.	Description	Item	Part Number	Qty.	Description
1	DA5792949SR	1	Valve Stack (inc. items 1A-1H)	2	DA4393190	1	Valve Block Body
1A	DA3697039	2	Bushing	3	DA5421009	1	Valve Plug
1C	B1016803	4	O-ring	4	DA4390118	2	Filter
1D	DA5422110	1	Comp. Spring	6	DA4405900	1	Solenoid Assembly (115V)
1E	CH279044	2	Glyd Ring		DA5714900	1	Solenoid Assembly (230V)
1F	DA3698290	3	Seat Spacer	9	PA1417027	1	Set Screw
1G	DC862949	1	Poppet Set	13	B1011803	3	O-Ring
1H	B1002503	2	O-Ring				

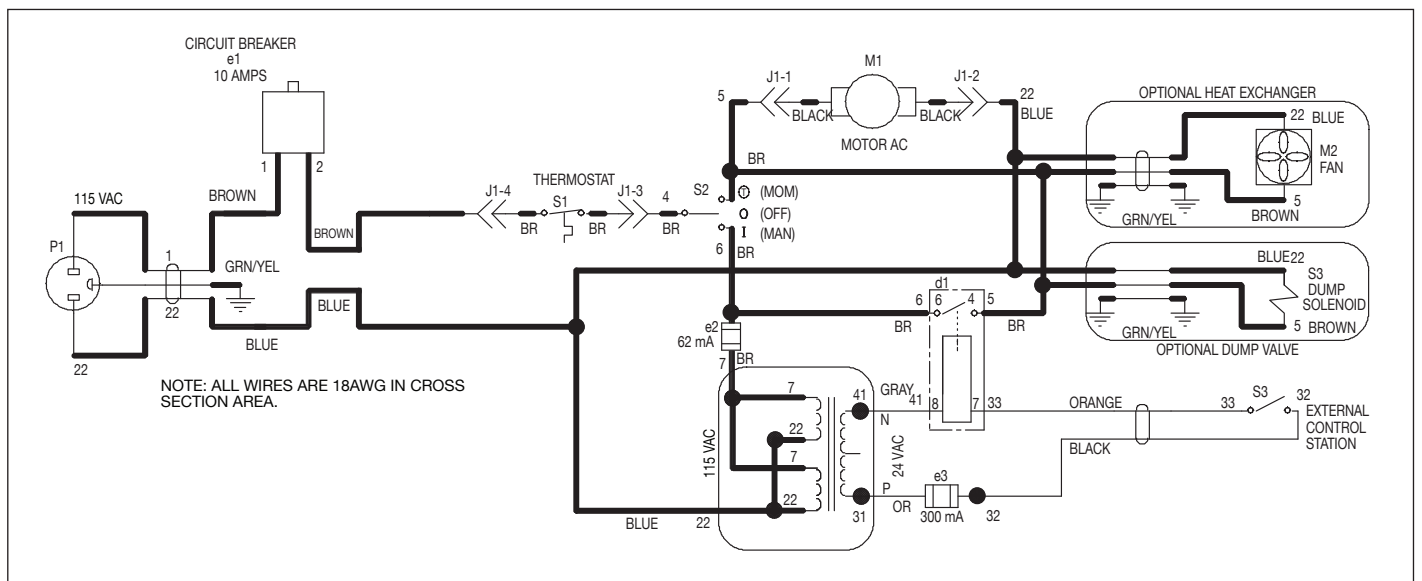

Figure 14, Electrical Schematic, 115V Models

