

Repair Parts Sheet	Revision	Revision Date	Product Code Beginning
L2815	Rev. B	01/2018	D

**NOTE:** Cylinder base, Item #1, is not available as a service item. Order complete cylinder.

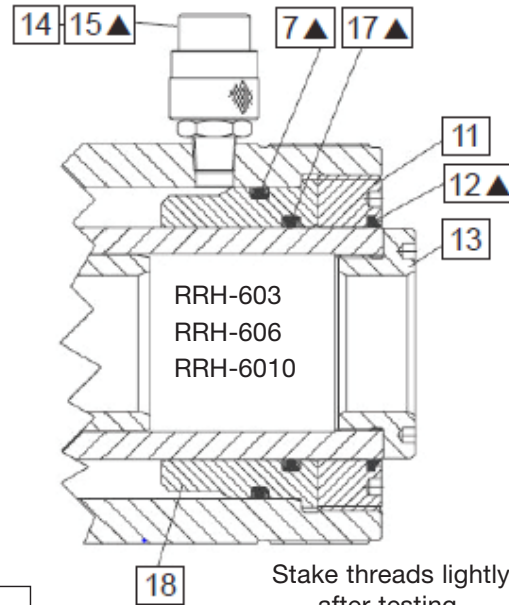

**NOTE:** Adjust Item No. 19 to 10,500 - 11,000 psi.

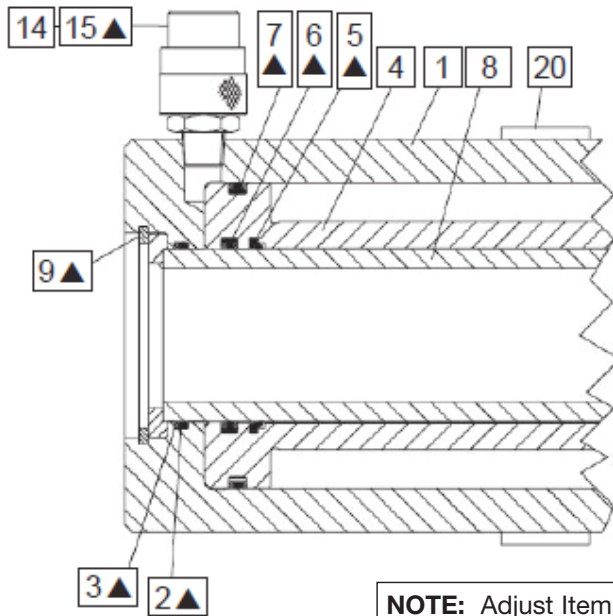
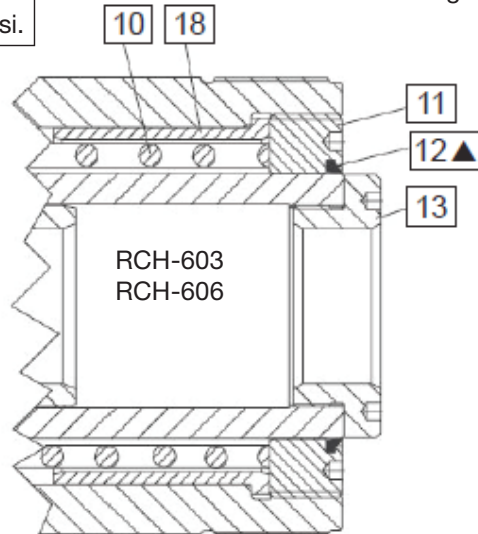
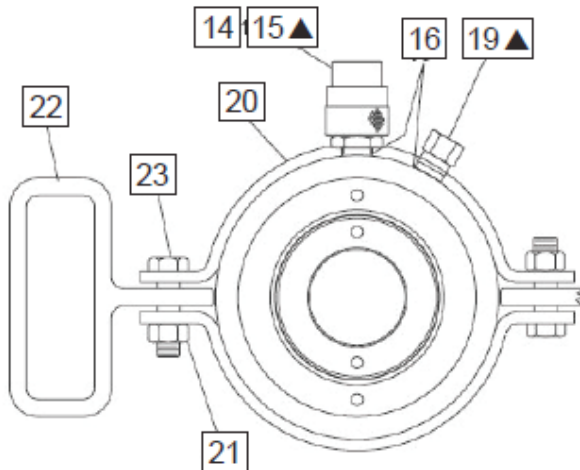

▲ = RCH60K50

# Repair Parts List

**L 2815**

Item	Description	Qty.	RCH603	RCH606	RRH603	RRH606	RRH6010	
1	Cylinder	1	Not available as spare part, order new cylinder.					
2	O-Ring	1	▲	▲	▲	▲	▲	
3	Back Up Ring	1	▲	▲	▲	▲	▲	
4	Plunger	1	DA4806040	DA4807040	DA4806040	DA4807040	DA4808040	
5	Wiper Ring	1	▲	▲	▲	▲	▲	
6	G-T® Ring	1	▲	▲	▲	▲	▲	
7a	G-T® Ring	1	▲	▲			▲	
7b	G-T® Ring	2			▲	▲	▲	
8	Center Tube	1	DA809900	DA4810900	DA4809900	DA4810900	DA4811900	
9	Retaining Ring	1	▲	▲	▲	▲	▲	
10	Spring	1	DA4816110	DA4816110				
11	Stop Ring	1	CR106044	CR106044	CR106044	CR106044	CR106044	
12	Wiper Ring	1	▲	▲	▲	▲	▲	
13	Saddle	2	CB891045	CB891045	CB891045	CB891045	CB891045	
14a	Coupler	1	CR400	CR400				
14b	Coupler	2			CR400	CR400	CR400	
15a	Dust Cap	1	▲	▲				
15b	Dust Cap	2			▲	▲	▲	
16	Flush Plug	2						
17	G-T® Ring	1			▲	▲	▲	
18	Inner Stop Ring	1	DA4814268	DA4814268	DA48143268	DA48143268	DA48143268	
19	Relief Valve	1			▲	▲	▲	
20	Collar (includes 21, 22, 23)	2	DA5238900SR	DA5238900SR	DA5238900SR	DA5238900SR	DA5238900SR	
21	Nut	2						
22	Handle	2						
23	Bolt	2						
24	Decal Hollow (not shown)	1	▲	▲	▲	▲	▲	
25	Decal Warning (not shown)	1	▲	▲	▲	▲	▲	
26	Decal Warning (not shown)	1	▲	▲	▲	▲	▲	
27	Dust Cap (not shown)	2	▲	▲	▲	▲	▲	
28	Collar Thread Protector (not shown)	1	▲	▲	▲	▲	▲	
	Repair Kit	1	RCH60K50	RCH60K50	RCH60K50	RCH60K50	RCH60K50	

▲ = indicates items included in and available only as part of Repair Kit RR100K50.



Item nr.	Model	Torque / Remarks
11	RCH / RRH	Use Loctite 222
14	RCH / RRH	54 - 81 Nm - 40 - 60 ft lbs
14	RCH / RRH	Use Loctite 545 or teflon tape
19	RRH	54 - 81 Nm - 40 - 60 ft lbs
19	RRH	Use Loctite 545 or teflon tape

To maintain your warranty, have your products inspected and repaired by an authorised Enerpac Service Centre.



**ENERPAC**   
www.enerpac.com