

L1106 Rev. C 08/19

IMPORTANT RECEIVING INSTRUCTIONS: Visually inspect all components for shipping damage. Shipping damage is not covered by warranty. If shipping damage is found, notify carrier at once. The carrier is responsible for all repair and replacement costs resulting from damage in shipment.

SAFETY FIRST



Carefully plan your system by selecting components designed to perform the intended operation and which will adequately perform with existing equipment. Always check the product limitations regarding pressure ranges, load capacities and set-up requirements. The system operating pressure must not exceed the pressure rating of the lowest rated component in the system. Read all CAUTIONS, WARNINGS, and INSTRUCTIONS included with, or attached to, each product. Follow all safety precautions to avoid personal injury or property damage during the system operation. ENERPAC CANNOT BE RESPONSIBLE FOR DAMAGE OR INJURY RESULTING FROM UNSAFE USE OF PRODUCT, LACK OF MAINTENANCE, OR INCORRECT PRODUCT AND SYSTEM APPLICATION. Contact Enerpac when in doubt as to safety precautions or applications.

DESCRIPTION

Enerpac cutters can be used for a variety of cutting operations. The table below lists the size and type of material your tool is capable of cutting.

Self-contained hydraulic cutters (WMC models) are extremely portable. Hydraulic cutterheads (WHC & WHR models) require 10,000 psi [700 bar] hydraulic pumps and are recommended for applications where many cuts must be made in a short amount of time.

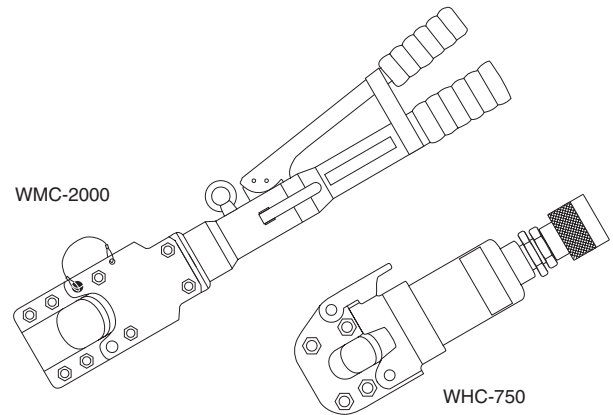

Cutting Capacity Chart		Hydraulic Cutterheads					Self-Contained Cutters							
Model		WHC -750	WHC -1250	WHC -2000	WHC -3380	WHC -4000	WHR -1250	WMC -580	WMC -750	WMC -1000*	WMC -1250	WMC -1580	WMC -2000	WMC -3380
Capacity (tons)		4	20	13	3	8	20	4	4	20	20	6	13	3
Maximum Diameter of Material (inch)	Steel Wire Rope 6x7, 6x12, 6x19 Hempcore or IWRC	.63	1.25	1.00	★	★	1.25	.63	.75	★	1.25	.75	1.00	★
	Copper Wire or Bar	.75	1.25	1.25	★	★	1.25	.63	.75	.75	1.25	.75	1.25	★
	Aluminum Wire or Bar	.75	1.25	1.25	★	★	1.25	.63	.75	.75	1.25	.75	1.25	★
	Soft Steel Bolts	.75	1.25	.88	★	★	1.25	.63	.69	.75	1.25	.75	.88	★
	Reinforcing Bar	.50*	1.00	★	★	★	1.00	.38	.50*	.75	.88	★	★	★
	Bare Copper Wire Strands	.75	1.25	2.00	3.00	3.50	1.25	.63	.75	★	1.25	1.50	2.00	3.00
	Bare Aluminum Wire Strands	.75	1.25	2.00	3.00	3.50	1.25	.63	.75	★	1.25	1.50	2.00	3.00
	ACSR Wire Strands	.75	1.25	2.00	★	★	1.25	.63	.75	★	1.25	1.50	2.00	★
	Guy Steel Wire Strands 1x7	.63	.88	.75	★	★	.88	.56	.56	★	.88	.63	.75	★
	Guy Steel Wire Strand 1x19	.63	.88	.75	★	★	.88	.56	.56	★	.88	.63	.75	★
	Telephone Cable	★	★	★	3.38	4.00	★	★	★	★	★	★	★	3.38
	Underground Cable (Power)	★	★	★	3.38	4.00	★	★	★	★	★	★	★	3.38
Grade 70 or 80 Alloy Chain	★	★	★	★	★	★	★	★	.50	★	★	★	★	



Unit is not designed to cut this size or type of material. Any attempt to do so will result in personal injury and/or damage to the unit and will void the warranty.

*** Low Alloy Steel Only**

* Model WMC-1000: Cuts .50" alloy chain grade 70 (type G7 transport or tie-down) or grade 80 (for overhead lifting applications).

OPERATION

PRELIMINARY INFORMATION: Be sure to observe safe operating procedures. Follow the warnings listed below and all other safety information contained in this document or decals attached to cutter. Failure to do so will result in personal injury and/or equipment damage.



CUTTING HAZARD: Keep hands away from cutter blades. Only one person should operate cutter. Do not have one person working near the blades while another person controls the pump.



Never use the cutter on electrically active or “hot” wire or cable. Be sure power has been turned off before working on electrical wire or cable.



When working with wire rope or cable, wrap section being cut to prevent pieces from flying loose as they are cut.

1. WHC and WHR models: Couple pump hose to cutter. Turn collar on coupler finger tight only. No tools are needed to make this connection.
2. Select material to be cut. When cutting short pieces of wire rope, clamp or tape it first to help prevent wires from jamming between the blade and head.
3. Inspect blade and cutting head. Cutting case hardened steel will dent blades and cutting heads. The blades will eventually fatigue and crack. Replace cracked blades immediately. DO NOT operate tool with cracked or chipped blades.
4. Unlatch cutter head.
5. Place material between blade and head shear.
6. **IMPORTANT:** Securely latch the cutter head.

CAUTION

Most broken blades are the result of not latching the cutter head. When the blade is advanced, it pushes on the cutter head. As the cutter head is pushed open, a diagonal force causes the blade to break, and, in some cases, the cutter head may crack.

7. On self-contained units, push release lever in toward cutter body. For hydraulic cutterheads, close or shift valve on pump to advance position.
8. Operate handle or pump until blade is fully advanced. DO NOT exceed maximum cutting limits printed on tool decal.

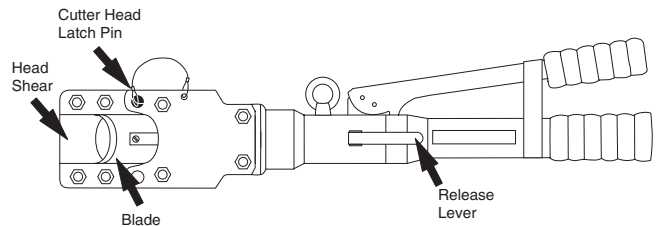

9. If the material being cut (usually wire rope or soft cables) seems to be cut but does not break free of the tool, the blade is hung up on something and needs to be removed. See “Troubleshooting” on page 3.
10. Lift release lever or shift pump to release position to retract blade. If blade does not retract, see “Troubleshooting” on page 3.
11. Return tool to carrying case to protect from dirt and corrosion. Always keep a spare blade on hand.

NOTE: Do not operate an empty cutter. The new blade and cutter head shear edges will “roll” slightly with the first material cut, creating a burr. This burr falls off as the cut takes place. Extending the blade prior to the first material cut will also raise a burr on the blade. With no material present to knock the burr off, the blade and head shear edges may lock together and the cutter will not retract. To correct this situation, the blade must be removed. Remove blade screw and blade. Unlatch cutter head.

Use a sharpening stone to remove burr from blade. Run the stone across the blade on the flat side (not the knife edge side). Keep the stone flat and parallel to the blade. Take care not to create a gap between the blade and head shear.

■ TROUBLESHOOTING

Problem	Cause	Solution
Blade will not advance.	Low oil level. Loose coupler connection. (WHC & WHR models)	Be sure reservoir is filled with Enerpac oil. Be sure all coupler connections are complete. Loose or incomplete coupler connections will cause complete or partial blockage of oil flow.
Blade will not retract.	Debris caught between cutter head shear and blade. Fluid release lever not working.	Remove blade screw from piston to release pressure. Remove cutter head latch pin or spring latch to free blade. Clean the blade and blade track. Hone the blade. See Maintenance step 6 on page 4. Lubricate the blade and track with silicone spray. See illustration below. Place wooden wedge against the release pin and lightly strike wedge with a hammer. The lever should release forward to by-pass and relieve pressure. The blade should retract. If debris is caught between the blade and cutter head, disassemble and clean as described above.
Unit leaks oil.	Seal damage caused by overloading cutter or by normal use of cutter over a period of time.	Replace seals. Seals are available as part of the Repair Kit for your cutter. An Authorized Enerpac Service Center can perform the repairs for you.

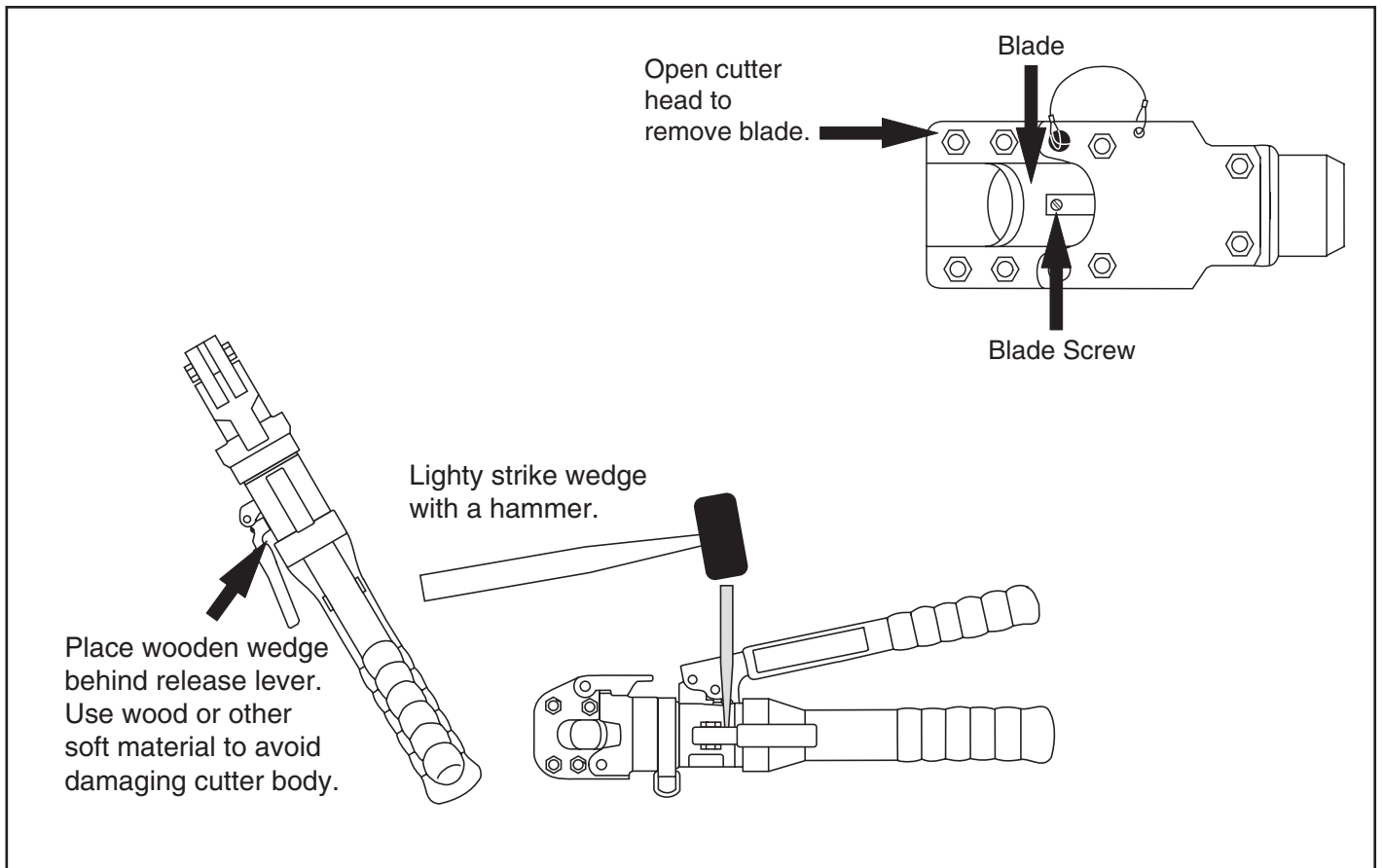

■ MAINTENANCE

Perform maintenance regularly to keep your hydraulic cutter in good operating condition.

1. Clean dirt from cutter using grease solvent.
2. Lubricate the head and blade with silicone spray rather than oil. Oil attracts dirt, silicone does not.
3. Keep reservoir full of clean oil. Drain all oil and refill with clean Enerpac oil every 12 months. Change oil more often under dirty environmental conditions.
Dispose of used oil properly.
4. If cutter has been used under water or in severe conditions, wash the cutter and lubricate immediately. Remove and clean the handle cylinder.
5. Repaint unit as necessary. If cutter is used in water regularly, repaint it with light colored corrosive resistant paint.

6. Keep blade and cutter head shear sharp. Hone blade by rubbing a sharpening stone across the blade on the flat side (not the knife edge side).

Keep the stone flat and parallel to the blade. Keep back bevel to a minimum, or blades will separate and break.

Discard cracked or chipped blades. New blades can be purchased separately.

7. Fluid leakage is usually the result of overloading the cutter and damaging the seals. Repair kits are available. Repair kits include piston seals, latch spring or pin, and blade screws. Contact your local Authorized Enerpac Service Center if your cutter needs to be repaired.

TO PROTECT YOUR WARRANTY, USE ONLY ENERPAC HYDRAULIC OIL.



<http://www.enerpac.com>