

▼ Shown: XC1201M



- Lightweight design with integrated handle and carrying strap for portability
- Bladder reservoir prevents contamination and allows pump usage in any position
- Powerful ½ horsepower motor and 28-volt Lithium-Ion battery deliver exceptional speed and run time
- High-strength fiberglass reinforced composite shroud for superior durability in demanding job site environments
- Cordless technology eliminates tripping hazards found in other electric or air powered pumps
- Available in torque wrench, dump and hold, single-acting and double-acting valve configurations



Performance of a Powered Pump

Portability of a Hand Pump



GA45GC Gauge Adaptor

Protect yourself from system overloading by simply ordering one part number for a pre-assembled gauge, adaptor block and coupler.

Page: 162



28-Volt Battery

The XC28V with Lithium-Ion technology for maximum battery performance.



Roll Cage

Optional Roll Cage XC-Series pumps. Please order model number **XCRCTK**.



Interactive Pendant

An interactive pendant is available on the **XC1302S** dump and hold models and **XC1502T** torque wrench

models. Operation, programming, and diagnostic status are provided to the user with yellow, green, and red LED as well as vibration pulses.

The **XC1302S** models can easily toggle between "jog operation" to "dump system pressure" and the **XC1502T** models allow "manual" and "auto cycle" mode.

◀ Power and simplicity for the toughest jobs.

Cordless Hydraulic Pump



XC-Series Cordless Hydraulic Pump

The XC-Series cordless pump is ideal for jobs that require a combination of portability, speed, and safety. These cordless pumps are perfect for remote locations without access to power, but also indoors where trip hazards, ergonomics or size is a concern. The XC-Series cordless pump is compatible with all Enerpac hydraulic tools and small to medium sized cylinders.

The Lithium-Ion battery provides superior run time.*

- 279 cuts of 3/8 inch reinforcing bar using the WHC750 Cutter
- 112 lifts with the WR5 Spreader
- 44 splits on 1-inch, grade 8 nuts using the NC3241 Nut Splitter
- 28 lifts of an RC104

*Actual number of cycles per charge will vary depending on condition of tool, battery and ambient conditions. Battery life with double-acting tools is approximately 75% of that for comparable, single-acting tools.

XC Series



Reservoir Capacity:
60 - 120 in³

Flow at Rated Pressure:
15 in³/min.

Maximum Operating Pressure:
10,000 psi

- ① Outlet "Advance" Port
- ② Oil Fill (must use funnel)
- ③ User Adjustable Relief Valve Access Port
- ④ Directional Control Valve *
- ⑤ Shoulder Strap Connection Points
- ⑥ Safety Lock Feature *
- ⑦ On/Off Switch *
- ⑧ Inlet "Retract" Port (double-acting models only)

* Single-acting and double-acting models only

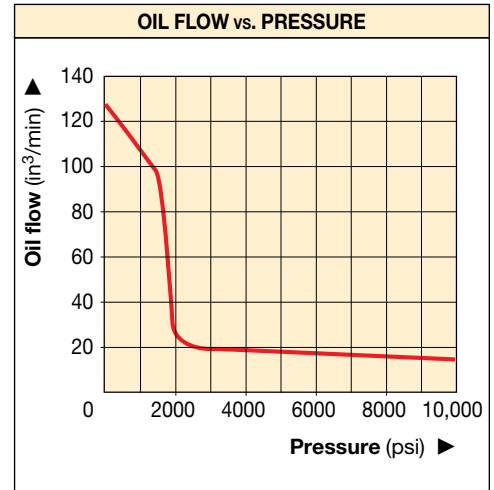
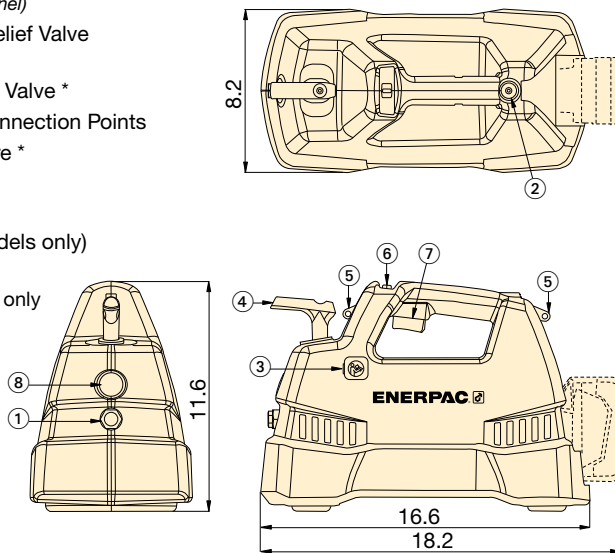

Battery Charger

1-hour quick charger.

XC115VC	115 VAC
XC230VC	230 VAC

▼ Take the battery pump anywhere without power cords or air hoses.



Pump Types (Used with Cylinder)	Oil Capacity (in ³)	Model Number*	Output Flow Rate (in ³ /min)			Valve Function	Charger Voltage (VAC)	Wt. ³⁾ (lbs)
			No Load	2000 psi	10,000 psi			
Single-acting	60	XC1201MB ¹⁾	125	30	15	3-way, 2-pos.	115	21.9
	120	XC1202MB	125	30	15			23.8
	60	XC1201ME ¹⁾	125	30	15	3-way, 2-pos.	230	21.9
	120	XC1202ME	125	30	15			23.8
	60	XC1201M ²⁾	125	30	15	3-way, 2-pos.	-	21.9
	120	XC1202M ²⁾	125	30	15			23.8
Single-acting	120	XC1302SB	125	30	15	Dump and Hold	115	25
	120	XC1302SE	125	30	15		230	25
	120	XC1302S ²⁾	125	30	15		-	25
Double-acting	60	XC1401MB	125	30	15	4-way,	115	22.3
	120	XC1402MB	125	30	15	3-pos.		24.2
	60	XC1401ME	125	30	15	4-way,	230	22.3
	120	XC1402ME	125	30	15	3-pos.		24.2
	60	XC1401M ²⁾	125	30	15	4-way,	-	22.3
	120	XC1402M ²⁾	125	30	15	3-pos.		24.2

1) Available as a cylinder-pump set, see page 62. 2) Batteries and charger not included.

3) Includes oil and battery

* "E" suffix indicates pumps have 230V chargers with European plug and CE CMC compliant.