

# ZU4-Series, Portable Electric Pumps

▼ Shown from left to right: ZU4304ME, ZU4420SE-H, ZU4304PE-K



- High-efficiency two-speed pump design – higher oil flow and bypass pressure
- Powerful 1,25 kW universal electric motor provides high power-to-weight ratio and excellent low-voltage operating characteristics
- High-strength, moulded composite shroud protects motor and electronics, while providing an ergonomic, non-conductive handle for easy transport.

### Pro-Series models only

- \* Back-lit LCD readout provides pressure display and a number of diagnostics and readout capabilities never offered on a portable pump before
  - pump usage information, hour and cycle counts
  - self-test, diagnostic and read-out capabilities
  - pressure readout and auto-mode pressure settings.



◀ Designed to be tough, the ZU4-Series with steel reservoirs will take the abuse of today's construction sites.

# Z

**Tough.  
Dependable.  
Innovative.**

## CLASS



### ZU4-Series Features and Options

For special requirements see factory installed features and options.

Page: **86**

### ▼ COMMON PUMP MODELS

For technical information and other options see next page.

#### BASIC PUMP TYPES

Select the model that suits your application. For special requirements contact your Enerpac office.

#### Manual Valve

- Ideal choice for most applications.
- Manual valve control, for single-acting or double-acting applications.
- Motor control on shroud.

#### Manual Valve with Pendant \*

- For light production and lifting applications.
- Manual valve for single- or double-acting cylinders.
- Manual valve with power seat (VM43LPS), ideal for post-tensioning applications.

#### Dump Valve \*

- Ideal for punching, crimping and cutting.
- For use when load-holding is not required.

#### Solenoid Valve \*

- Ideal for lifting applications and where remote control is required.
- With VE32 valve, motor only runs during the advance function, while holding and retracting, the motor is off.
- Motor runs continuously on pumps with VE33 and VE43 valves.

\* Pendant with 3 m. cord controls valve and motor.

# ZU4-Series, Electric Pumps



## Z-Class – A Pump For Every Application

Patented Z-Class pump technology provides high by-pass pressures for increased productivity – important in applications using long hose runs and high pressure-drop circuits, like heavy lifting or certain double-acting tools.

Enerpac ZU4-Series Pumps are built to power small to large-sized cylinders or hydraulic tools, or wherever high-speed, intermittent duty, remote hydraulic power is needed.

### Classic Electric Pump

- The Classic has traditional electro-mechanical components (transformers, relays and switches) in place of solid-state electronics.

The Classic delivers durable, safe and efficient hydraulic power for demanding markets like construction, post-tensioning and foundation repair.

### Standard Electric Pump

- For applications that do not require digital display features of the Premium Pump. Available in all manual or jog versions.

### Pro Electric Pump

- Digital (LCD) display features a built-in hour meter and shows self-diagnostic, cycle-count and low voltage warning information.

Pressure can also be displayed when the pump is equipped with an optional pressure transducer.



## ZU4 Series



Reservoir Capacity:

**4 - 40 litres**

Flow at Rated Pressure:

**1,0 l/min**

Motor Size:

**1,25 kW**

Maximum Operating Pressure:

**700 bar**

Pump type	Used with Cylinder		Valve Function			Valve Type <sup>1)</sup>	Pump Control	Useable Oil Capacity (litres)	Model Number 230 V - 1 phase - 50 Hz <sup>2)</sup>			Pro Electric Weight <sup>3)</sup> (kg)
									Classic Electric	Standard (STD) Electric	Pro Electric (incl. LCD)	
	●		●		●	VM32	Manual	4,0	ZU4204RE	ZU4204ME	ZU4204LE	27
	●		●		●	VM32	Manual	8,0	ZU4208RE	ZU4208ME	ZU4208LE	32
	●		●	●	●	VM33	Manual	8,0	ZU4308RE	ZU4308ME	ZU4308LE	32
	●		●	●	●	VM33	Manual	20,0	ZU4320RE	ZU4320ME	ZU4320LE	50
		●	●	●	●	VM43	Manual	8,0	ZU4408RE	ZU4408ME	ZU4408LE	32
		●	●	●	●	VM43	Manual	20,0	ZU4420RE	ZU4420ME	ZU4420LE	50
	●		●		●	VM32	Remote (Man.)	4,0	ZU4204PE	ZU4204JE	ZU4204KE	27
	●		●		●	VM32	Remote (Man.)	8,0	ZU4208PE	ZU4208JE	ZU4208KE	32
	●		●		●	VM32	Remote (Man.)	20,0	ZU4220PE	ZU4220JE	ZU4220KE	50
	●		●	●	●	VM33	Remote (Man.)	8,0	ZU4308PE	ZU4308JE	ZU4308KE	32
		●	●	●	●	VM43	Remote (Man.)	8,0	ZU4408PE	ZU4408JE	ZU4408KE	32
		●	●	●	●	VM43	Remote (Man.)	20,0	ZU4420PE	ZU4420JE	ZU4420KE	50
	●		●		●	VE32D	Remote	4,0	N/A	N/A	ZU4104DE	29
	●		●		●	VE32D	Remote	8,0	N/A	N/A	ZU4108DE	33
	●		●		●	VE32D	Remote	20,0	N/A	N/A	ZU4120DE	51
						-	-	-	-	-	-	-
						-	-	-	-	-	-	-
						-	-	-	-	-	-	-
	●		●		●	VE32	Remote	4,0	N/A	N/A	ZU4204SE	29
	●		●		●	VE32	Remote	8,0	N/A	N/A	ZU4208SE	33
	●		●	●	●	VE33	Remote	8,0	N/A	N/A	ZU4308SE	39
		●	●	●	●	VE43	Remote	8,0	N/A	N/A	ZU4408SE	39
		●	●	●	●	VE43	Remote	20,0	N/A	N/A	ZU4420SE	56
						-	-	-	-	-	-	-
						-	-	-	-	-	-	-
						-	-	-	-	-	-	-

<sup>1)</sup> See valves section for technical information on valve types. <sup>2)</sup> See custom order matrix on page 89 for other voltage options.

<sup>3)</sup> Subtract 1,4 kg for Standard (STD) Electric models.



## Pressure Transducer \*

- More durable than analog gauges (against mechanical and hydraulic shock)
- More accurate than analog gauges (0,5% full scale of pump)
- Calibration can be fine tuned for certification
- "Set pressure" feature turns off motor at user defined pressure (or shifts valve to neutral on models with VE33/VE43 valves)
- Display pressure in bar, psi or MPa.

\* Requires LCD Electric

Accessory Kit Model Number	Adjustable Pressure Range (bar)	Switch-point repeatability	Dead-band (bar)
ZPT-U4 *	3,5 - 700	± 0,5%	3,5

\* Add suffix **T** for factory installation.



## Level/Temperature Switch

- Ensures feedback on pump oil level and temperature
- Drop-in design allows for easy installation to pump reservoir
- Plugs directly into pump electrical enclosure
- Built-in thermal sensing shuts off pump when unsafe operating temperature is reached
- Oil level switch shuts down pump before oil reaches an unsafe operating level.

Model Number	Operating Temperature (°C)	Maximum Pressure (bar)	 (kg)
ZLS-U4 *	5-110	10	0,1

\* Add suffix **L** for factory installation.



## Hoses

Enerpac offers a complete line of high-quality hydraulic hoses. To ensure the integrity of your system, specify only Enerpac hydraulic hoses.

Page: 116



## Gauges

Minimize the risk of overloading and ensure long, dependable service from your equipment. Refer to the System Components section for a full range of gauges.

Page: 124



## Foot Switch

- Hands-free remote control on solenoid dump and 3-position valves
- With 3 metres cord.

Accessory Kit Modelnr.	Can be used on ZU4-Series Pumps with
ZCF-2 *	Solenoid VE-Series valves

\* Add suffix **U** for factory installation.



## Roll Cage

- Protects pump
- Provides greater pump stability.

Accessory Kit Modelnr.	Fits on reservoir
ZRC-04 *	4 and 8 litres <sup>1)</sup>
ZRC-04H *	4 and 8 litres <sup>2)</sup>
ZRB-10 *	10 litres
ZRB-20 *	20 litres
ZRB-40 *	40 litres

\* Add suffix **R** for factory installation.

<sup>1)</sup> Without heat exchanger

<sup>2)</sup> With heat exchanger.



## Skid Bar

- Provides easy two-hand lift
- Provides greater pump stability on soft or uneven surfaces.

Accessory Kit Modelnr.	Fits on reservoir	 (kg)
SBZ-4 *	4 and 8 l without heat exchanger	2,2
SBZ-4L *	4 and 8 l with heat exchanger	3,2

\* Add suffix **K** for factory installation.

# ZU4-Series, Options & Accessories



## ZU4-Series Options

Accessory Kits can be installed by the customer.

See chart below for all possible options on ZU4-Series pumps:

- Classic Electric,
  - Standard (STD) Electric (no LCD)
  - Pro Electric (with LCD).
- Refer to page 89 for ordering matrix.

ZU4-Series Options	Factory Installed			Accessory Kits		
	Classic Electric	Standard Electric	Pro Electric	Classic Electric	Standard Electric	Pro Electric
Return Line Filter	F	F	F	ZPF	ZPF	ZPF
Skid Bar <sup>1)</sup>	K	K	K	SBZ	SBZ	SBZ
Roll Cage	R	R	R	ZRC	ZRC	ZRC
Heat Exchanger	H	H	H	ZHE	ZHE	ZHE
1000 bar Pressure Gauge	G	G	G	G	G	G
Pressure Transducer	-	-	T	-	-	ZPT-U4
Level/Temperature Switch	-	-	L	-	-	ZLS-U4
Foot Switch	-	-	U	-	-	ZCF-2

<sup>1)</sup> Skid Bar not in combination with Roll Cage.

## ZU4 Series



Reservoir Capacity:

**4 - 40 litres**

Flow at Rated Pressure:

**1,0 l/min**

Motor Size:

**1,25 kW**

Maximum Operating Pressure:

**700 bar**



### Return Line Filter

- 25 micron filter removes contaminants from return oil flow
- By-pass valve prevents damage if filter is dirty
- With maintenance indicator.

Accessory Kit Modelnr.	Maximum Pressure (bar)	Maximum Oil Flow (l/min)	By-pass Setting (bar)
ZPF *	13,8	45,4	1,7

\* Add suffix **F** for factory installation.



### Heat Exchanger

- Removes heat from by-pass oil to provide cooler operation
- Stabilizes oil viscosity, increasing oil life and reduces wear of pump and other hydraulic components.

Accessory Kit Nr.	Can be used on	(kg)
ZHE-U115 *	115 V pumps	4,1
ZHE-U230 *	230 V pumps	4,1

\* Add suffix **H** for factory installation.



### Heat Exchanger

Can be factory installed on ZU4-Series Classic, Standard Electric and Pro Electric models.

- Extends system life.
- Stabilizes oil temperature at a maximum of 54 °C at 21 °C ambient temperature.

Do not exceed maximum oil flow and pressure ratings. Heat exchanger is not suitable for water-glycol or high water based fluids.

Thermal Transfer *		Maximum Pressure	Maximum Oil Flow	Voltage
Btu/h	kJoule	(bar)	(l/min)	(VDC)
900	950	20,7	26,5	12

\* At 1,9 l/min at 21 °C ambient temperature.

# ZU4, Specifications and Dimensions

## OIL FLOW VERSUS PRESSURE

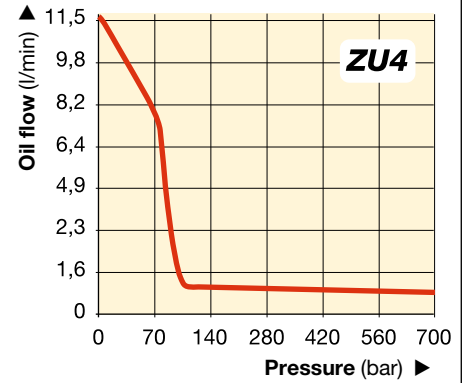

### ZU4-SERIES PERFORMANCE CHART

Motor Size (kW)	Output Flow Rate at 50 Hz (l/min)				Motor Electrical Specifications (Volts-Ph-Hz)	Sound Level (dBA)	Relief Valve Adjustment Range (bar)
	7 bar	50 bar	350 bar	700 bar			
1,25	11,5	8,8	1,2	1,0	115-1-50/60 230-1-50/60	85-90	140-700

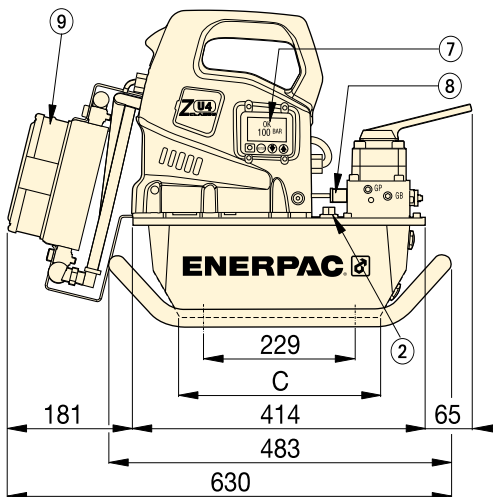

ZU4-Series with 4 and 8 litres reservoirs

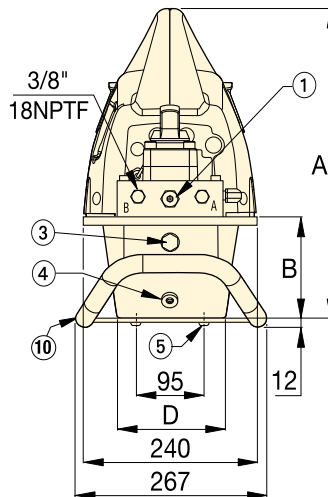

3/8"-18 NPTF Advance and Retract Ports

- ① User adjustable relief valve
- ② Oil fill port SAE #10 7/8"-14 UNF-2B
- ③ Oil level sight gauge
- ④ Oil drain 1/2" NPTF
- ⑤ M8, 6 mm deep
- ⑥ Handles on all 10, 20 and 40 litres reservoirs.

Options (see chart on page 87):

- ⑦ Back-lit LCD Electric
- ⑧ Pressure transducer
- ⑨ Heat Exchanger
- ⑩ Skid Bar  
Fits 4 and 8 litres reservoirs
- ⑪ Handle guard installed on all 10, 20 and 40 litres reservoirs
- ⑫ Reservoir handles (not shown) included on all 10, 20 and 40 litres reservoirs.

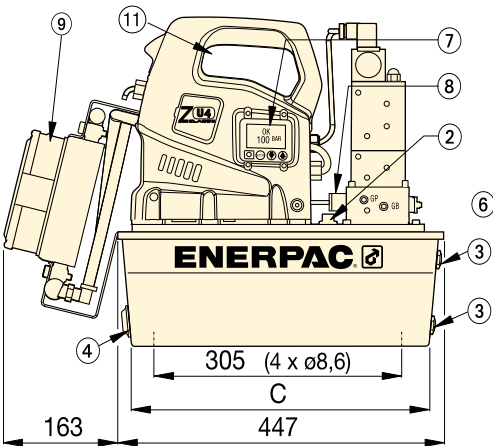

ZU4-Series with 10, 20 and 40 litres reservoirs  
(left view shown without side handle)

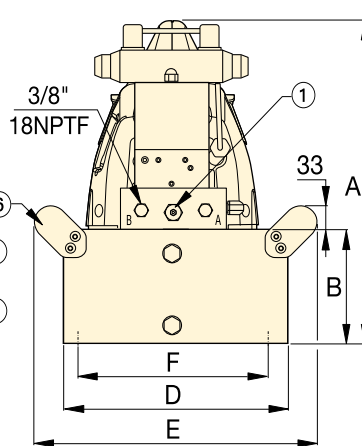

### Pump Dimensions (mm)

Usable Reservoir Capacity (litres)	A	B	C	D	E	F
4,0	424	142	279	152	-	-
8,0	424	142	279	206	-	-
10,0	439	157	413	305	384	279
20,0	465	180	413	422	500	396
40,0	551	269	399	503	576	480

# ZU4-Series, Pump Ordering Matrix

## CUSTOM BUILD YOUR ZU4-SERIES PUMP

If the ZU4-Series pump that would best fit your application cannot be found in the chart on page 85, you can easily build your custom ZU4-Series pump here.

▼ This is how a ZU4-Series pump model number is built up:

<b>Z</b>	<b>U</b>	<b>4</b>	<b>1</b>	<b>04</b>	<b>D</b>	<b>E</b>	<b>-</b>	<b>H</b>	<b>K</b>	<b>T</b>
1	2	3	4	5	6	7		8		
Product Type	Motor Type	Flow Group	Valve Type	Reservoir Size	Valve Operation	Voltage		Options and Accessories		

### 1 Product Type

**Z** = Pump Series

### 2 Motor Type

**U** = Universal electric motor

### 3 Flow Group

**4** = 1,0 l/min @ 700 bar

### 4 Valve Type (see page 110-111 for more details)

- 1** = Dump (VE32D)
- 2** = 3 way/2 position manual or electric (VM32 or VE32)
- 3** = 3 way/3 position manual or electric (VM33 or VE33)
- 4** = 4 way/3 position manual or electric (VM43 or VE43)
- 6** = 3 way/3 position locking manual w/po check (VM33L)
- 7** = 3 way/2 position manual (VM22)
- 8** = 4 way/3 position locking manual w/po check (VM43L)
- 9** = 4 way/3 position manual w/power seating (VM43-LPS)

### 5 Reservoir Size (useable capacity)

- 04** = 4 litres
- 08** = 8 litres
- 10** = 10 litres <sup>1)</sup>
- 20** = 20 litres <sup>1)</sup>
- 40** = 40 litres <sup>1)</sup>

<sup>1)</sup> reservoir includes side handles.

### 6 Valve Operation

- D** = Dump (solenoid valve w/pendant and LCD Electric)
- J** = Jog (manual valve w/pendant and Standard Electric (i.e. w/o LCD))
- K** = Jog (manual valve w/pendant and LCD Electric)
- L** = Manual valve w/LCD Electric (w/o pendant)
- P** = Manual valve w/pendant and classic electric (i.e. w/o LCD)
- R** = Manual valve w/Classic electric (i.e. w/o LCD) [w/o pendant]
- M** = Manual valve w/Standard Electric (i.e. w/o LCD) [w/o pendant]
- S** = Solenoid valve w/pendant and LCD Electric

### 7 Voltage

- B** = 115V, 1 ph, 50/60Hz
- E** = 208-240V, 1 ph, 50/60 Hz (w/European plug and CE EMC compliant)
- I** = 208-240V, 1 ph, 50/60 Hz (w/NEMA 6-15 plug)

### 8 Options and Accessories (see page 87 for possibilities)

- F** = Filter
- G** = 0-1000 bar pressure gauge (ø 63,5 mm) <sup>1)</sup>
- H** = Heat exchanger
- K** = Skid Bar (4 and 8 litres reservoirs only)
- L** = Level/temperature switch <sup>2)3)</sup>
- N** = No reservoir handles (includes lifting eyes)
- R** = Roll Cage
- T** = Pressure transducer <sup>2)</sup>
- U** = Foot switch

<sup>1)</sup> Pressure gauge not available on pump models with pressure transducer

<sup>2)</sup> These options require Pro Electric

<sup>3)</sup> Not available on 4 and 8 litres reservoirs

## ZU4 Series



Reservoir Capacity:

**4 - 40 litres**

Flow at Rated Pressure:

**1,0 l/min**

Motor Size:

**1,25 kW**

Maximum Operating Pressure:

**700 bar**



### Speed Chart

To determine how a specific pump will operate your cylinder, see the Pump-Cylinder Speed Chart in the 'Yellow Pages'.

Page: **269**



### Ordering Example

**Model Number:**  
**ZU4108DE-HKT**

is a Pro Electric model pump with LCD, 1,0 l/min oil flow at 700 bar, pump with a dump valve, an 8 liter reservoir, operates on 230V, heat exchanger, pressure transducer and skid bar.



### Spring Centred Valve Kits

VM and VC-Series manual 3-position valves can be easily converted into spring centred valves. With these

retro-fit kits the handle will automatically move into the neutral valve position when released.

Page: **111**