

Inductive sensor BI7-M18-AD4X-H1141

TURCK
works

Industrial
Automation

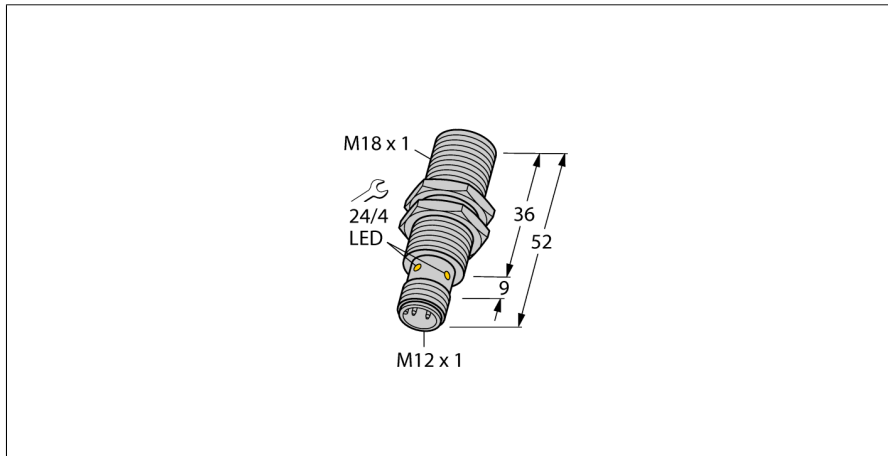

- Threaded barrel, M18 x 1
- Chrome-plated brass
- DC 2-wire, 10...65 VDC
- NO contact
- M12 x 1 male connector

Wiring Diagram

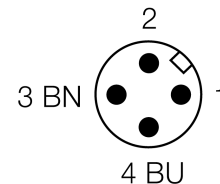
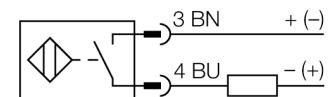

Functional principle

Inductive sensors detect metal objects contactless and wear-free. For this, they use a high-frequency electromagnetic AC field that interacts with the target. Inductive sensors generate this field via an RLC circuit with a ferrite coil.

Type designation	BI7-M18-AD4X-H1141
Ident-No.	4414541
Ident-No (TUSA)	T4414541
Rated switching distance Sn	7 mm
Mounting conditions	flush
Assured switching distance	≤ (0,81 x Sn) mm
Correction factors	St37 = 1; Al = 0.3; stainless steel = 0.7; Ms = 0.4
Repeatability	≤ 2 % of full scale
Temperature drift	≤ ± 10 %
Hysteresis	1...15 %
Ambient temperature	-25...+70 °C
Operating voltage	10... 65VDC
Residual ripple	≤ 10 % U _{in}
DC rated operational current	≤ 100 mA
Residual current	≤ 0.6 mA
Rated insulation voltage	≤ 0.5 kV
Short-circuit protection	yes/ cyclic
Voltage drop at I _s	≤ 5 V
Smallest operating current I _m	≥ 3 mA
Switching frequency	1 kHz
Construction	Threaded barrel, M18 x 1
Dimensions	52 mm
Housing material	Metal, CuZn, chrome-plated
Active area material	Plastic, PA12-GF30
Max. tightening torque housing nut	25 Nm
Electrical connection	Flange connector, M12 x 1
Vibration resistance	55 Hz (1 mm)
Shock resistance	30 g (11 ms)
Protection class	IP67
MTTF	2283 years acc. to SN 29500 (Ed. 99) 40 °C
Switching state	LED yellow

Inductive sensor BI7-M18-AD4X-H1141

TURCK
works

Industrial
Automation

Distance D	2 x B
Distance W	3 x Sn
Distance T	3 x B
Distance S	1.5 x B
Distance G	6 x Sn

Diameter of the active area B \varnothing 18 mm

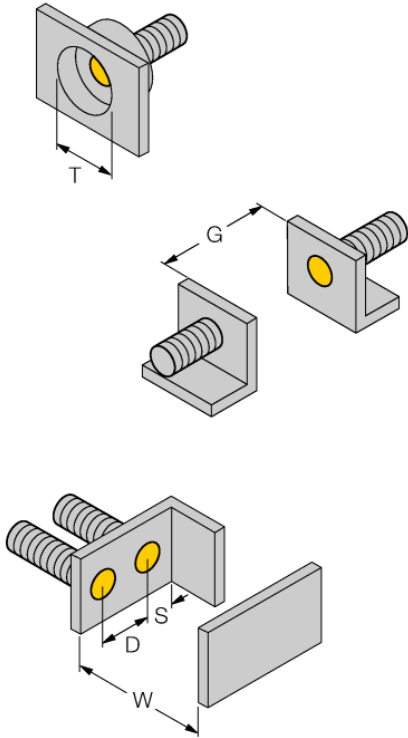

**Inductive sensor
BI7-M18-AD4X-H1141**



Accessories

Type code	Ident-No.	Description	
BST-18B	6947214	Fixing clamp for threaded barrel devices, with dead-stop; material: PA6	
QM-18	6945102	Quick-mount bracket with dead-stop; material: Chrome-plated brass Male thread M24 x 1.5. Note: The switching distance of proximity switches can be reduced by the use of quick-mount brackets.	
MW-18	6945004	Mounting bracket for threaded barrel devices; material: Stainless steel A2 1.4301 (AISI 304)	
BSS-18	6901320	Mounting bracket for smooth and threaded barrel devices; material: Polypropylene	

Wiring accessories

Type code	Ident-No.	Description	
RKC4T-2/TEL	6625010	Connection cable, female M12, straight, 3-pin, cable length: 2 m, sheath material: PVC, black; cULus approval; other cable lengths and qualities available, see www.turck.com	