

DASH	FRAME	C	B	2F	2FF	BS
9419	182/184	16.63 [422.28]	7.44 [188.93]	4.50 [114.30]	5.50 [139.70]	2.99 [75.98]

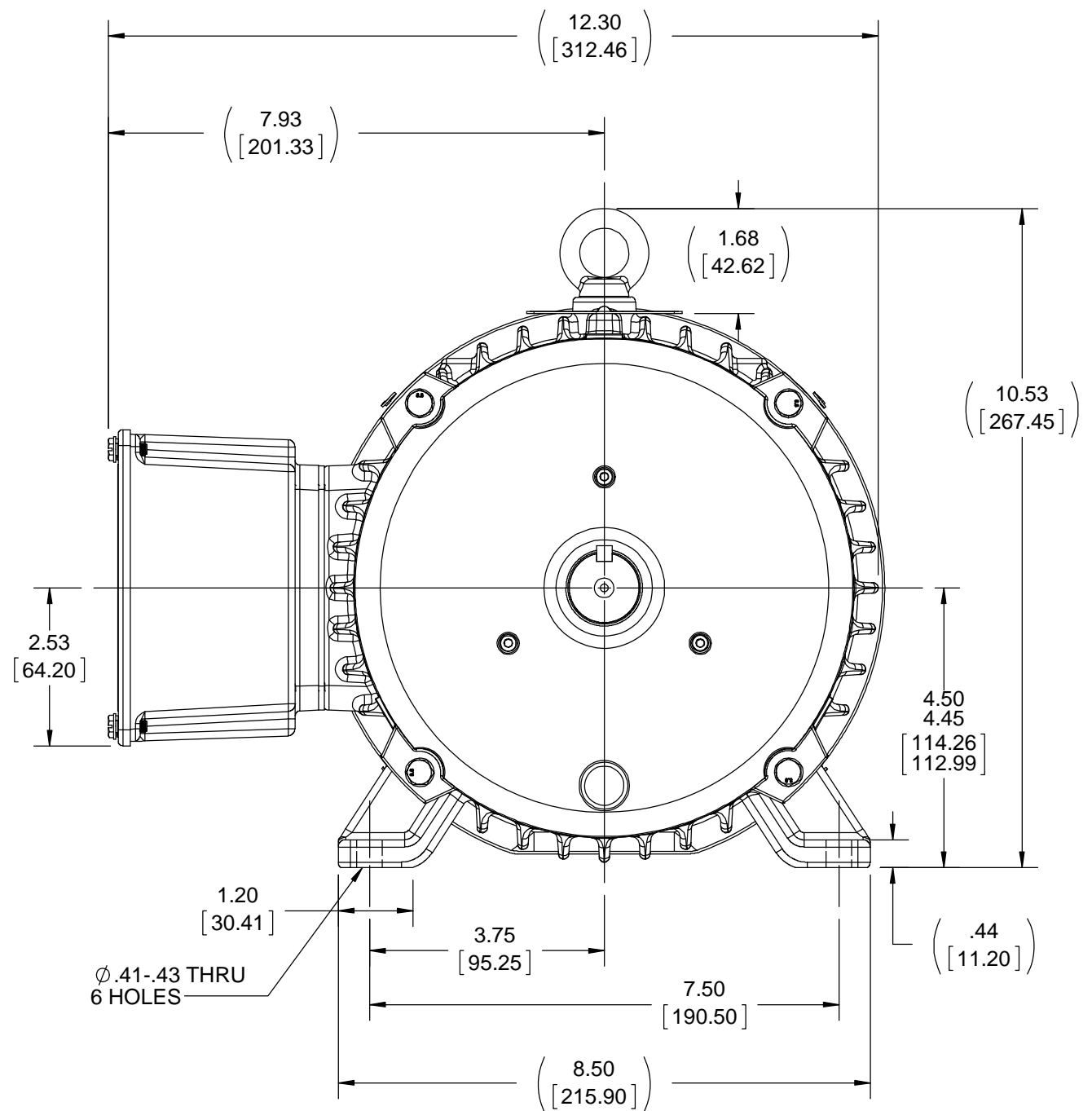
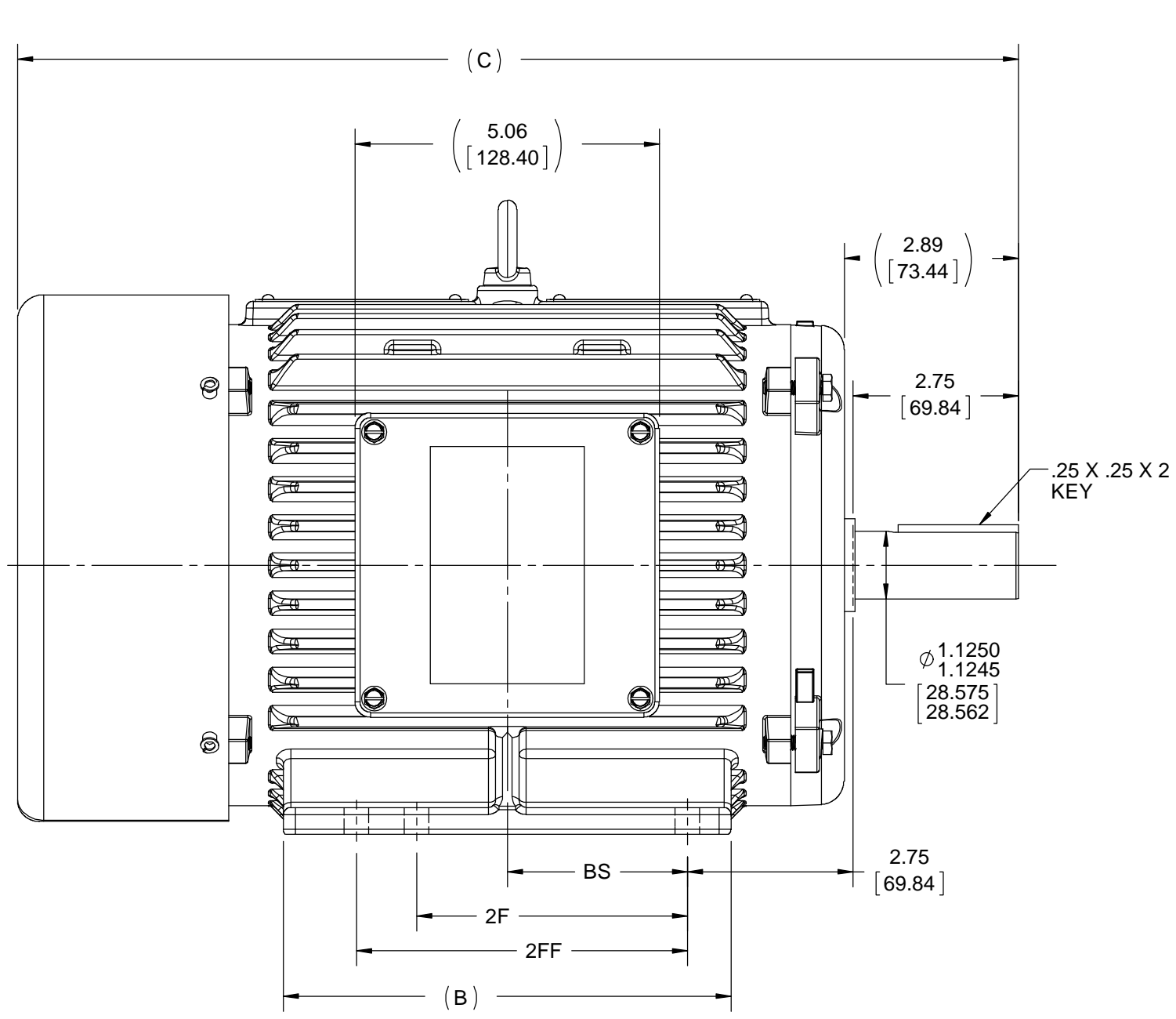

B
A

B
A

- NOTES: (UNLESS OTHERWISE SPECIFIED)
- ALL DIMENSIONS & TOLERANCES APPLY POST- FINISH OR PLATING.
 - CRITICAL TO FUNCTION DIMENSIONS ARE INSIDE OVAL BORDER. QUERY SOLID MODEL (IGES) FOR COMPLETE PART DEFINITION.

DRAWING REVISION F	REVISION BY GNK	DATE 08/09/2018
ECO ECO-0150486	APPROVED BY GNK	DATE 08/09/2018
ECO DESCRIPTION DRAWING UPDATED COPYRIGHT REGAL BELOIT AMERICA, INC. ALL RIGHTS RESERVED. PROPRIETARY AND CONFIDENTIAL INFORMATION - THIS DOCUMENT IS THE PROPERTY OF REGAL BELOIT AMERICA, INC. ("OWNER") AND CONTAINS OWNER'S PROPRIETARY INFORMATION. ANY PERSON, CORPORATION OR OTHER FIRM RECEIVING IT IS DEEMED, BY RECEIVING IT, TO AGREE THAT IT, AND/OR ANY PART OF IT, SHALL NOT BE DISCLOSED TO ANY PERSON, CORPORATION OR OTHER ENTITY, DUPLICATED, AND/OR USED, EXCEPT AS EXPRESSLY APPROVED IN WRITING IN ADVANCE BY OWNER. THIS DOCUMENT SHALL BE RETURNED TO OWNER UPON REQUEST. IT MAY BE SUBJECT TO CERTAIN RESTRICTIONS UNDER APPLICABLE EXPORT CONTROL LAWS AND REGULATIONS.		

TOLERANCES UNLESS OTHERWISE SPECIFIED:

DEC.	mm	INCH	ANGLE
.X	±2.5	[±0.10]	±7' 30"
.XX	±0.50	[±0.020]	
.XXX	±0.130	[±0.0051]	
.XXXX	±0.0130	[±0.00051]	

REMOVE BURRS & BREAK SHARP EDGES: .08/.38 [.003/.015] X 45°
CORNER FILLETS: R.50 [.020]
MACHINED SURFACES: 200 INCH/mm 5.1
INCH SHOWN IN [BRACKETS]

DRAWN BY	REGAL ™ Regal Beloit America, Inc.		
DATE	DESCRIPTION OUTLINE NOVAMAX, 182/184T, TEFC, RIGID		
APPROVED BY	MATERIAL	PROCESS/FINISH	
DATE	SIZE	DRAWING NUMBER	SHEET
REFERENCE	B	520-00319	1 OF 1
THIRD ANGLE PROJECTION			