

PRODUCT INFORMATION PACKET

Model No: 215TTDWD16345
Catalog No: E759A
10,1800,DP,215T,3/60/575
Open Drip Proof (ODP)



Regal and Marathon are trademarks of Regal Beloit Corporation or one of its affiliated companies.
©2018 Regal Beloit Corporation, All Rights Reserved. MC017097E





Nameplate Specifications

Output HP	10 Hp	Output KW	7.5 kW
Frequency	60 Hz	Voltage	575 V
Current	10.5 A	Speed	1765 rpm
Service Factor	1.15	Phase	3
Efficiency	91.7 %	Duty	CONTINUOUS
Insulation Class	B	Design Code	B
KVA Code	H	Frame	215T
Enclosure	DP	Overload Protector	NOT
Ambient Temperature	40 °C	Drive End Bearing Size	6307
Opp Drive End Bearing Size	6206	UL	Recognized
CSA	Y	CE	Y
IP Code	12		

Technical Specifications

Electrical Type	SQ CAGE IND RUN	Starting Method	ACROSS THE LINE
Poles	4	Rotation	REV
Mounting	RIGID	Motor Orientation	HORIZONTAL
Drive End Bearing	BALL	Opp Drive End Bearing	BALL
Frame Material	ROLLED STEEL	Shaft Type	T
Overall Length	17.3 in	Frame Length	11.15 in
Shaft Diameter	1.38 in	Shaft Extension	3.47 in
Assembly/Box Mounting	F1/F2 CAPABLE		
Outline Drawing	SS86500-1115	Connection Diagram	5102.01

This is an uncontrolled document once printed or downloaded and is subject to change without notice. Date Created: 04/05/2018

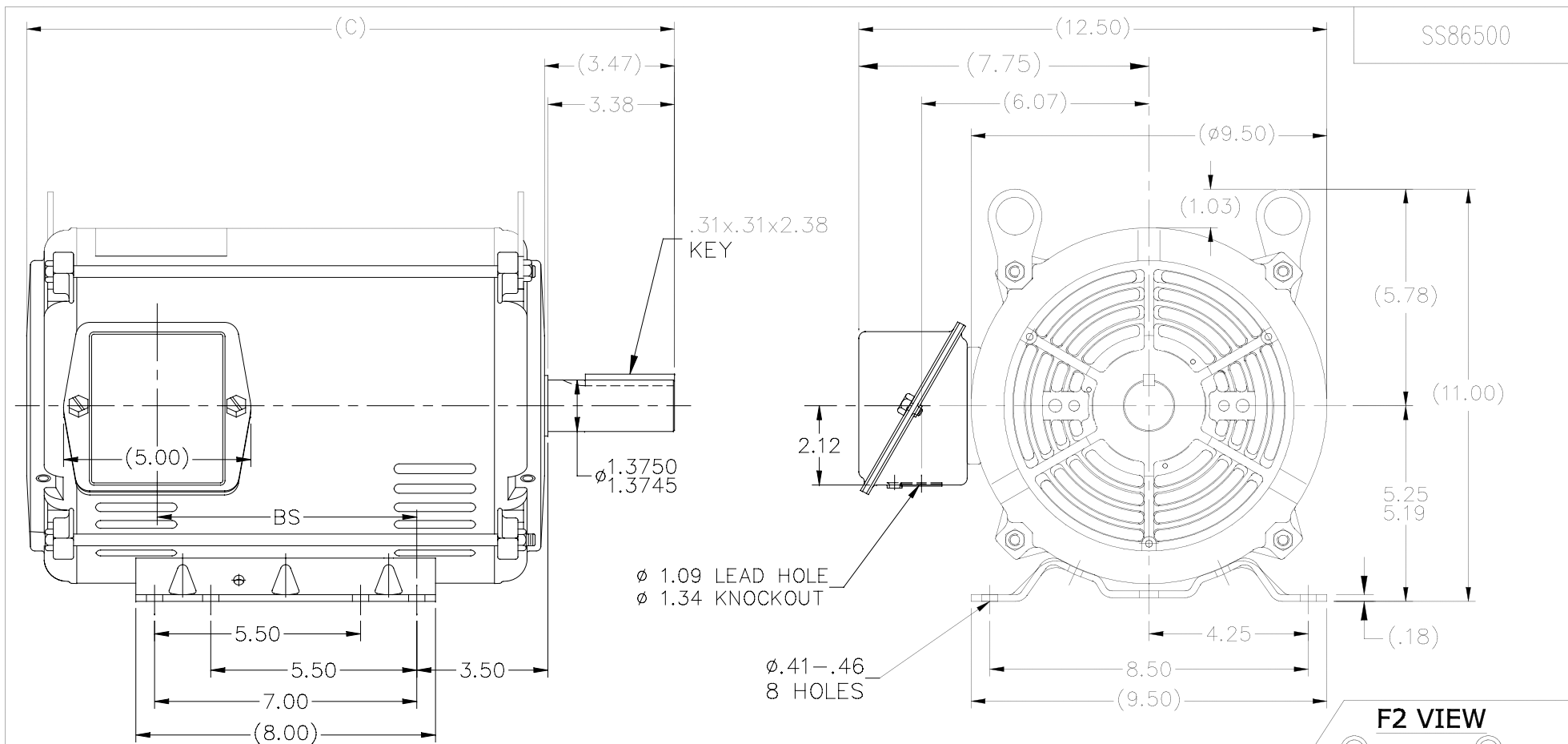

SS86500

.31x.31x2.38
KEY

ø 1.09 LEAD HOLE
ø 1.34 KNOCKOUT

ø.41-.46
8 HOLES

F2 VIEW

- NOTES:
1. NAMEPLATE TO BE READ FROM C'BOX SIDE OF MOTOR.
 2. BOX CAN BE MOUNTED IN 90° STEPS.
 3. BOX CAN BE MOUNTED ON OPPOSITE SIDE BY REMOVING BRACKETS AND TURNING FRAME 180°. (EXCEPT AS NOTED.)

DASH	FR.	C	BS	MOUNTING
1115	213/15T	17.30	6.93	F1/F2
1240	213/15T	18.55	8.18	F1 ONLY

14	TITLE BLOCK LOGO CHANGE PER ECO-0078542	MDV 06/09/2015	MDV	TOLERANCES UNLESS SPECIFIED		 Regal Beloit America, Inc.	DRAWN SMC 04-13-1993		
13	FOR FRAME 11.15 MOUNTING NOTE ADDED	UD 12/13/12	SR	DEC.	INCHES		CHK MOL 04-04-1993		
12	ADDED: F2 VIEW.	KVN 2/10/2009	SVL	.X	±.1	APPD DRN 04-13-1993			
11	UPDATED DRAWING	TJW 04/27/2007		.XX	±.03	TITLE OUTLINE	SCALE 1=4		
10	REM'VD. DASH 965 FROM SERIES CN38252	RWR 07-20-2004	ML	.XXX	±.005	210 FR. - BB - TS - DR. PR.	REF		
9	REDRAWN IN AUTOCAD	TAT 06-29-2004	ML	.XXXX	±.0005	MAT'L.	FMF		
NO.	REVISION	BY & DATE	CHK	ANG	±7'30"	FINISH	PREV		
THIS DRAWING IN DESIGN AND DETAIL IS OUR PROPERTY AND MUST NOT BE USED EXCEPT IN CONNECTION WITH OUR WORK ALL RIGHTS OF DESIGN AND INVENTION ARE RESERVED THIS IS AN ELECTRONICALLY GENERATED DOCUMENT - DO NOT SCALE THIS PRINT			RFP	CAD FILE ss86500		SIZE A	DRAWING NO. SS86500	PAGE 1 OF 1	REV. 14
			DIST LB						

005102-01

VIEW FROM OUTSIDE OF MOTOR AT SWITCH END.

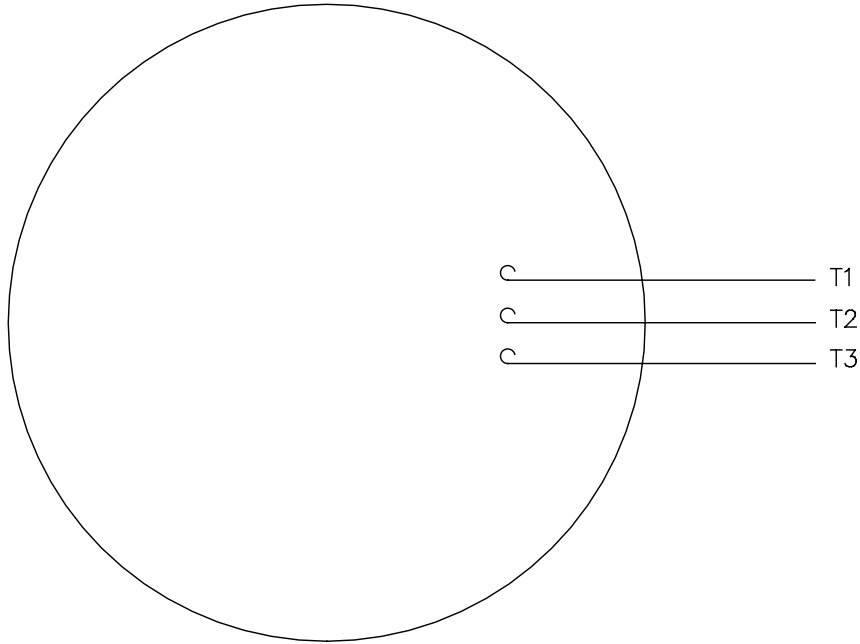

LINE LEADS

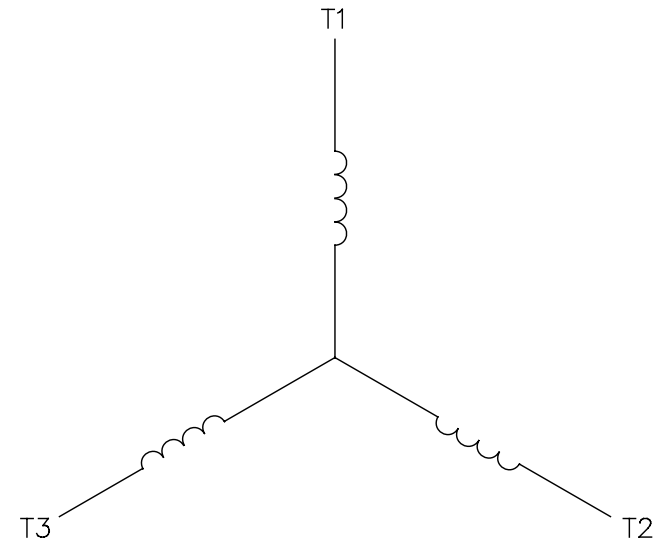

CONNECT LEADS AS FOLLOWS
FOR FOUR CONDUCTOR CORD ()

CORD	L1 (RED)	L2 (WHITE)	L3 (BLACK)	(GREEN)
MOTOR	T1	T2	T3	GROUND

				TOLERANCES UNLESS SPECIFIED		REGAL™ Regal Beloit America, Inc.		DRAWN JRW 9/11/75			
				DEC.	INCHES			CHK			
				.X	±.1			APPD JCW 9/11/75			
08	UPDATED TO REGAL LOGO	SAJ 06/26/15	AJY	.XX	±.01	TITLE EXTERNAL WIRING DIAGRAM TYPE "T" W/O PROTECTOR		SCALE 1=1			
07	UPDATED TO CURRENT STANDARDS	DBT 5/30/97		.XXX	±.005			REF W-T6343-6			
06	REDRAWN ON CAD; ADDED DECAL NUMBER	SAW 1/24/95		.XXXX	±.0005			FMF 6T17FB7			
NO.	REVISION	BY & DATE	CHK	ANG	±1/2"	FINISH		PREV			
THIS DRAWING IN DESIGN AND DETAIL IS OUR PROPERTY AND MUST NOT BE USED EXCEPT IN CONNECTION WITH OUR WORK ALL RIGHTS OF DESIGN AND INVENTION ARE RESERVED THIS IS AN ELECTRONICALLY GENERATED DOCUMENT - DO NOT SCALE THIS PRINT				RFP	5/1/02	CAD FILE 00510201		SIZE	DRAWING NO.		REV.
				DIST	BRF-NLV	A	005102-01		08		

CERTIFICATION DATA SHEET

Model#: 215TTDWD16345 AA WINDING#: K2154505 NONE 3
 CONN. DIAGRAM: 005102.01 ASSEMBLY: F1/F2 CAPABLE
 OUTLINE: SS86500-1115

TYPICAL MOTOR PERFORMANCE DATA

HP	KW	SYNC. RPM	F.L. RPM	FRAME	ENCLOSURE	KVA CODE	DESIGN
10	7.50	1800	1765	215T	DP	H	B

PH	Hz	VOLTS	FL AMPS	START TYPE	DUTY	INSL	S.F	AMB°C	ELEVATION
3	60	575	10.5	ACROSS THE LINE	CONTINUOUS	B4	1.15	40	3300

FULL LOAD EFF: 91.7	3/4 LOAD EFF: 92.1	1/2 LOAD EFF: 91.4	GTD. EFF	ELEC. TYPE	NO LOAD AMPS
FULL LOAD PF: 77.8	3/4 LOAD PF: 72	1/2 LOAD PF: 60.2	90.2	SQ CAGE IND RUN	5.3

F.L. TORQUE	LOCKED ROTOR AMPS	L.R. TORQUE	B.D. TORQUE	F.L. RISE°C
29.7 LB-FT	64.4	62.3 LB-FT 210	83.3 LB-FT 280	25

SOUND PRESSURE @ 3 FT.	SOUND POWER	ROTOR WK^2	MAX. WK^2	SAFE STALL TIME	STARTS /HOUR	APPROX. MOTOR WGT
60 dBA	70 dBA	1 LB-FT^2	74 LB-FT^2	20 SEC.	2	150 LBS.

*** SUPPLEMENTAL INFORMATION ***

DE BRACKET TYPE	ODE BRACKET TYPE	MOUNT TYPE	ORIENTATION	SEVERE DUTY	HAZARDOUS LOCATION	DRIP COVER	SCREENS	PAINT
STANDARD	STANDARD	RIGID	HORIZONTAL	FALSE	NONE	FALSE	NONE	BLUE (ENAMEL)

BEARINGS		GREASE	SHAFT TYPE	SPECIAL DE	SPECIAL ODE	SHAFT MATERIAL	FRAME MATERIAL
DE	OPE						
BALL	BALL	POLYREX EM	T	NONE	NONE	AISI 1045 (C-240)	ROLLED STEEL
6307	6206						

THERMO-PROTECTORS				THERMISTORS	CONTROL	SPACE /n HEATERS
THERMOSTATS	PROTECTORS	WDG RTDs	BRG RTDs			
NONE	NOT	NONE	NONE	NONE	FALSE	NONE VOLTS

If Inverter equals NONE, contact factory for further information

INVERTER TORQUE: NONE
INV. HP SPEED RANGE: NONE
ENCODER: NONE
NONE NONE
NONE NONE PPR
BRAKE: NONE NONE
NONE P/N NONE
NONE NONE
NONE FT-LB NONE V NONE Hz

*
N
O
T
E
S
*

DATE: 06/22/2017 07:35:36 AM
 FORM 3531 REV.3 02/07/99
 ** Subject to change without notice.

Data Sheet

Date: 19-06-2017
 Customer: _____
 Attention: _____
 Submitted by: FAREEDA DUDEKULA



215TTDWD16345

Submittal

Data @ 575 V

Motor Load Data

Load	0%	25%	50%	75%	100%	115%	125%	LR
Current (Amps)	5.3	5.6	6.8	8.5	10.5	11.8	12.7	64.4
Torque (ft-lb)	0.00	7.5	14.7	22.2	29.7	34.4	37.4	62.3
RPM	1800	1790	1784	1775	1765	1,758	1755	0
Efficiency (%)		90.8	91.4	92.1	91.7	90.8	90.5	
P.F. (%)	4.7	37.7	60.2	72.0	77.8	80.2	81.3	42.0

Motor Speed Data

	LR	Pull-Up	BD	Rated	Idle
Speed (RPM)	0	900	1575	1765	1800
Current (Amps)	64.4	63.2	39.2	10.5	5.3
Torque (ft-lb)	62.3	58.0	83.3	29.7	0.00

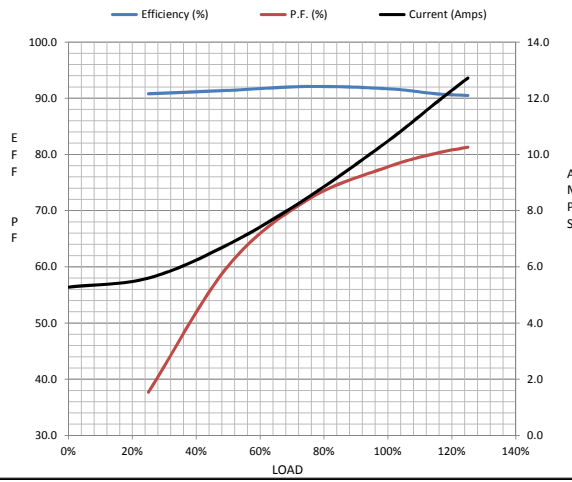

Information Block				
HP	10.0			
Sync. RPM	1800			
Frame	215			
Enclosure	DP			
Construction	TDW			
Voltage	575 V			
Frequency	60 Hz			
Design	B			
LR Code letter	H			
Service Factor	1.15			
Temp Rise @ FL	25 ° C			
Duty	CONT			
Ambient	40 ° C			
Elevation	1,000 feet			
Rotor/Shaft wk ²	1.00 Lb-Ft ²			
Ref Wdg	K2154505 NONE			
Sound Pressure @ 1M	60 dBA			
VFD Rating	NONE			
Outline Dwg	SS86500-1115			
Conn. Diag	005102.01			
Additional Specifications:				
0				
365THFS8036				
EQUIV CKT (OHMS / PHASE)				
R1	R2	X1	X2	Xm
0.9750	0.6910	3.2090	3.6700	60.9400

Speed -Torque Curve

