

PRODUCT INFORMATION PACKET

Model No: 365TTFC6633
Catalog No: Y820A
75,1800,TEFC,365T,3/60/230/460
Other Purpose



Regal and Marathon are trademarks of Regal Beloit Corporation or one of its affiliated companies.
©2018 Regal Beloit Corporation, All Rights Reserved. MC017097E





Nameplate Specifications

Output HP	75 Hp	Output KW	56 kW
Frequency	60 Hz	Voltage	230/460 V
Current	172/86 A	Speed	1782 rpm
Service Factor	1.15	Phase	3
Efficiency	95.4 %	Duty	CONTINUOUS
Insulation Class	F	Design Code	C
KVA Code	G	Frame	365T
Enclosure	TEFC	Overload Protector	NOT
Ambient Temperature	40 °C	Drive End Bearing Size	NU314
Opp Drive End Bearing Size	6313	UL	Recognized
CSA	Y	CE	Y
IP Code	55		

Technical Specifications

Electrical Type	SQ CAGE INV RATED	Starting Method	PWS & YDRUN OR INV
Poles	4	Rotation	REV
Mounting	RIGID	Motor Orientation	HORIZONTAL
Drive End Bearing	ROLLER	Opp Drive End Bearing	BALL
Frame Material	CAST IRON	Shaft Type	T
Overall Length	38.39 in	Shaft Diameter	2.38 in
Shaft Extension	5.88 in	Assembly/Box Mounting	F1/F2 CAPABLE
Outline Drawing	SS620611	Connection Diagram	EE7308AA

This is an uncontrolled document once printed or downloaded and is subject to change without notice. Date Created: 04/05/2018

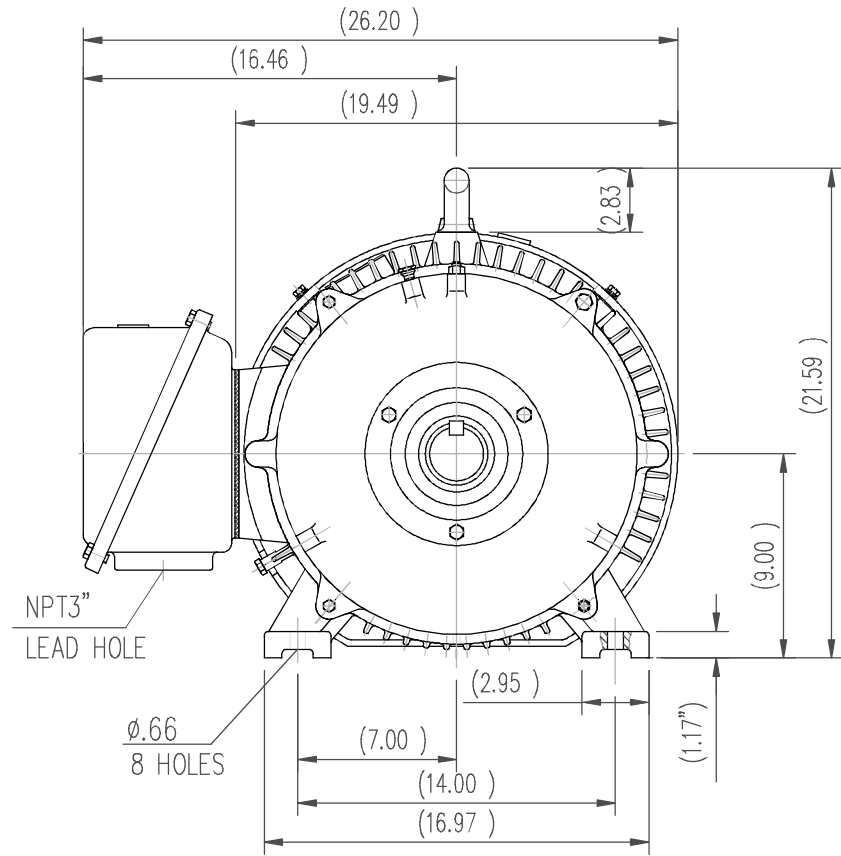
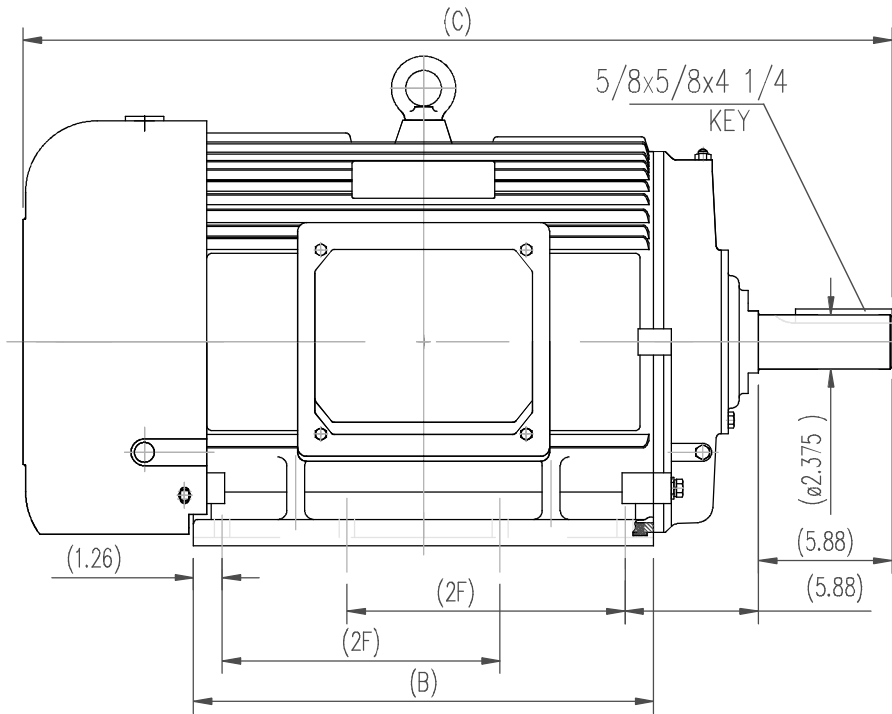

364T	36.61	18.5	11.25
365T	38.39	20.28	12.25
Frame	C	B	2F

		TOLERANCES UNLESS SPECIFIED		REGAL REGAL-BELOIT CORPORATION		DRAWN ZOU 7.17.2012	
		DEC.	INCHES			CHK	
		.X	±.1			APPD	
		.XX	±.03	TITLE		SCALE 1=1	
		.XXX	±.005	364/365T TEFC-SEVERE DUTY		REF	
		.XXXX	±.0005	MAT'L.		FMF	
NO.	REVISION	BY & DATE	CHK	ANG	FINISH	PREV	
THIS DRAWING IN DESIGN AND DETAIL IS OUR PROPERTY AND MUST NOT BE USED EXCEPT IN CONNECTION WITH OUR WORK ALL RIGHTS OF DESIGN AND INVENTION ARE RESERVED THIS IS AN ELECTRONICALLY GENERATED DOCUMENT - DO NOT SCALE THIS PRINT				RFP	CAD FILE	SS620611	SIZE
				DIST			DRAWING NO.
							SS620611
							REV.



LOW VOLTAGE



HIGH VOLTAGE



DRAWING REVISION K	REVISION BY AJW	DATE 07-17-2015
ECO ECO-0081632	APPROVED BY T. VUE	DATE 07-17-2015
ECO DESCRIPTION REV'D IEC MARKINGS PER IEC 60034-8		
<small>COPYRIGHT REGAL BELOIT AMERICA, INC. ALL RIGHTS RESERVED. PROPRIETARY AND CONFIDENTIAL INFORMATION - THIS DOCUMENT IS THE PROPERTY OF REGAL BELOIT AMERICA, INC. ("OWNER") AND CONTAINS OWNER'S PROPRIETARY INFORMATION. ANY PERSON, CORPORATION OR OTHER FIRM RECEIVING IT IS DEEMED, BY RECEIVING IT, TO AGREE THAT IT, AND/OR ANY PART OF IT, SHALL NOT BE DISCLOSED TO ANY PERSON, CORPORATION OR OTHER ENTITY, DUPLICATED, AND/OR USED, EXCEPT AS EXPRESSLY APPROVED IN WRITING IN ADVANCE BY OWNER. THIS DOCUMENT SHALL BE RETURNED TO OWNER UPON REQUEST. IT MAY BE SUBJECT TO CERTAIN RESTRICTIONS UNDER APPLICABLE EXPORT CONTROL LAWS AND REGULATIONS.</small>		



DRAWN BY LZ	Regal Beloit America, Inc.	
DATE 01-12-1994		
APPROVED BY GK	DESCRIPTION CONN DIAGRAM-EXTERNAL 3Ø-2/1 DELTA-12 LEADS	
DATE 01-14-1994		
REFERENCE	MATERIAL	PROCESS/FINISH
THIRD ANGLE PROJECTION	SIZE A	DRAWING NUMBER EE7308AA
		SHEET 1 OF 1

CERTIFICATION DATA SHEET

Model#: 365TTFC6633 AA **WINDING#:** CHT36540008 NONE 1
CONN. DIAGRAM: EE7308AA **ASSEMBLY:** F1/F2 CAPABLE
OUTLINE: SS620611

TYPICAL MOTOR PERFORMANCE DATA

HP	KW	SYNC. RPM	F.L. RPM	FRAME	ENCLOSURE	KVA CODE	DESIGN
75&60	56&45	1800	1782&1485	365T	TEFC	G	C

PH	Hz	VOLTS	FL AMPS	START TYPE	DUTY	INSL	S.F	AMB°C	ELEVATION
3	60/50	230/460#190/ 380	172/86&165/8 2.5	PWS & YDRUN OR INV	CONTINUOUS	F7	1.15/1.15	40	3300

FULL LOAD EFF: 95.4&95	3/4 LOAD EFF: 95.4	1/2 LOAD EFF: 95	GTD. EFF	ELEC. TYPE	NO LOAD AMPS
			94.5	SQ CAGE INV RATED	52 / 26

F.L. TORQUE	LOCKED ROTOR AMPS	L.R. TORQUE	B.D. TORQUE	F.L. RISE°C
221 LB-FT	1084 / 542	460 LB-FT 208	575 LB-FT 260	65

SOUND PRESSURE @ 3 FT.	SOUND POWER	ROTOR WK^2	MAX. WK^2	SAFE STALL TIME	STARTS /HOUR	APPROX. MOTOR WGT
75 dBA	85 dBA	20 LB-FT^2	- LB-FT^2	20 SEC.	2	10050 LBS.

***** SUPPLEMENTAL INFORMATION *****

DE BRACKET TYPE	ODE BRACKET TYPE	MOUNT TYPE	ORIENTATION	SEVERE DUTY	HAZARDOUS LOCATION	DRIP COVER	SCREENS	PAINT
STANDARD	STANDARD	RIGID	HORIZONTAL	PREMIUM SEVERE DUTY	NONE	FALSE	NONE	BLUE (EPOXY)

BEARINGS		GREASE	SHAFT TYPE	SPECIAL DE	SPECIAL ODE	SHAFT MATERIAL	FRAME MATERIAL
DE	OPE						
ROLLER NU314	BALL 6313	SHC- 100/POLYREX	T	NONE	NONE	4140 STRESSPROOF (C-214)	CAST IRON

THERMO-PROTECTORS				THERMISTORS	CONTROL	SPACE /n HEATERS
THERMOSTATS	PROTECTORS	WDG RTDs	BRG RTDs			
NONE	NOT	NONE	NONE	NONE	FALSE	NONE VOLTS

If Inverter equals NONE, contact factory for further information

INVERTER TORQUE: CONSTANT 10:1 INV. HP SPEED RANGE: NONE
ENCODER: NONE NONE NONE NONE NONE PPR
BRAKE: NONE NONE NONE P/N NONE NONE NONE NONE FT-LB NONE V NONE Hz

*
N
O
T
E
S
*

Data Sheet

Date: 19-06-2017
 Customer: _____
 Attention: _____
 Submitted by: FAREEDA DUDEKULA



365TTC6633

Submittal

Data @ 460 V

Motor Load Data

Load	0%	25%	50%	75%	100%	115%	125%	LR
Current (Amps)	26.0	33.0	48.0	66.0	86.0	98.0	108	542
Torque (ft-lb)	0.00	55.0	110	166	221	254	280	460
RPM	1800	1795	1790	1788	1782	1,780	1778	0
Efficiency (%)		93.0	95.0	95.4	95.4	95.0	94.5	
P.F. (%)	4.5	57.0	77.0	83.0	85.0	86.0	86.0	35.0

Motor Speed Data

	LR	Pull-Up	BD	Rated	Idle
Speed (RPM)	0	900	1715	1782	1800
Current (Amps)	542	475	300	86.0	26.0
Torque (ft-lb)	460	400	575	221	0.00

Information Block

HP	75.0			
Sync. RPM	1800			
Frame	365			
Enclosure	TEFC			
Construction	TFC			
Voltage	30/460#190/38V			
Frequency	60 Hz			
Design	A			
LR Code letter	G			
Service Factor	1.15			
Temp Rise @ FL	65 ° C			
Duty	CONT			
Ambient	40 ° C			
Elevation	1,000 feet			
Rotor/Shaft wk ²	20.0 Lb-Ft ²			
Ref Wdg	CHT36540008 NONE			
Sound Pressure @ 1M	75 dBA			
VFD Rating	CONSTANT 10:1			
Outline Dwg	SS620611			
Conn. Diag	EE/308AA			
Additional Specifications:				
0				
365THFS8036				
EQUIV CKT (OHMS / PHASE)				
R1	R2	X1	X2	Xm
0.0490	0.0300	0.2870	0.4230	10.0250

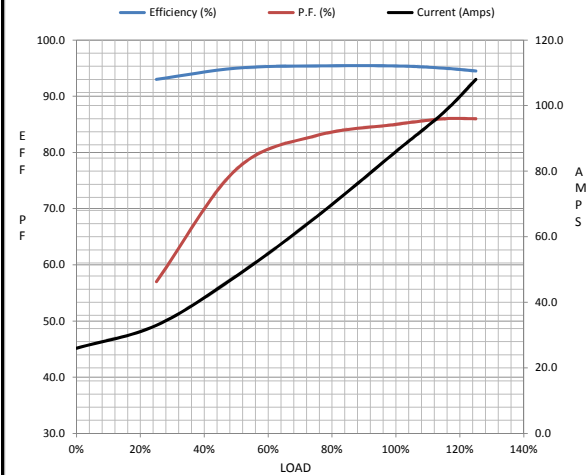

Speed -Torque Curve

