



104W LED high bay fixture with over 10,000 lumens. Reduces energy consumption by up to 70%. Ideal for large spaces, including warehouses, gymnasiums, and distribution centers.

Color: White

Weight: 27.3 lbs

Project:	Type:
Prepared By:	Date:

Driver Info		LED Info	
Type	Constant Current	Watts	104W
120V	1.03A	Color Temp	3000K (Warm)
208V	0.65A	Color Accuracy	72 CRI
240V	0.56A	L70 Lifespan	100,000 Hours
277V	0.49A	Lumens	14,773 lm
Input Watts	121.9W	Efficacy	121.2 lm/W

Technical Specifications

Other

BAYLED104 with Bi-Level Operation:

Allows 50% and 100% output modes

Warranty:

RAB warrants that our LED products will be free from defects in materials and workmanship for a period of five (5) years from the date of delivery to the end user, including coverage of light output, color stability, driver performance and fixture finish. RAB's warranty is subject to all terms and conditions found at rablighting.com/warranty.

Compliance

UL Listed:

Suitable for damp locations with cord and hook.
Suitable for wet locations with 3/4" pendant stem.

IESNA LM-79 & LM-80 Testing:

RAB LED luminaires and LED components have been tested by an independent laboratory in accordance with IESNA LM-79 and LM-80.

DLC Listed:

This product is on the Design Lights Consortium (DLC) Qualified Products List and is eligible for rebates from DLC Member Utilities. Designed to meet DLC 5.1 requirements.
DLC Product Code: PWZF0IRS

LED Characteristics

LEDs:

Multi-chip, high-output, long-life LEDs

Color Consistency:

3-step MacAdam Ellipse binning to achieve consistent fixture-to-fixture color

Color Stability:

LED color temperature is warranted to shift no more than 200K in color temperature over a 5-year period

Color Uniformity:

RAB's range of Correlated Color Temperature follows the guidelines of the American National Standard for Specifications for the Chromaticity of Solid State Lighting (SSL) Products, ANSI C78.377-2017.

Performance

Lifespan:

100,000-Hour LED lifespan based on IES LM-80 results and TM-21 calculations

Wattage Equivalency:

Replaces 320W Metal Halide

Construction

Ambient Temperature:

Suitable for use in up to 55°C (131°F)

Thermal Management:

Superior heat sinking with external Air-Flow fins

Housing:

Precision die-cast aluminum housing and door frame with 3-foot 600V power cord

Lens:

Tempered glass

Reflector:

Specular vacuum metallized polycarbonate

Gaskets:

High-temperature silicone

Finish:

Our environmentally friendly polyester powder coatings are formulated for high-durability and long-lasting color

Green Technology:

Mercury and UV free. RoHS-compliant components.

Installation

Recommended Mounting Height:

30 ft

Technical Specifications (continued)

Electrical

Drivers:

Constant Current, 800mA, Class 2 with 6 kV surge protection, 100-277VAC, 50/60 Hz

THD:

9.8% at 120V, 10.04% at 277V

Power Factor:

99.3% at 120V, 93.6% at 277V

Dimensions

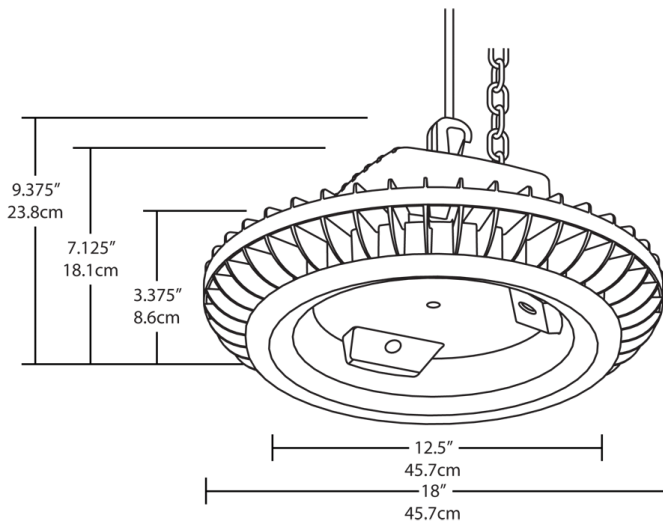

Features

High output, high efficiency LED high bay

Bi-level and dimming models available when installed with pendant by others

Polysshield and wire guard accessories available for additional protection

100,000-hour lifespan

5-Year, No-Compromise Warranty

Ordering Matrix

Family	Wattage	Color Temp	Finish	Options	Other Options
BAYLED	104	Y	W	/BL	
	78 = 78W 104 = 104W	Blank = 5100K Cool N = 4000K Neutral Y = 3000K Warm	W = White	Blank = No Option /BL = Bi-Level /D10 = 0-10V Dimming /D10/LC = 0-10V Dimming w/Lightcloud	Blank = Standard USA = BAA Compliant