

BALDOR • RELIANCE

Customer information packet

VLECP84104T-4

60M 4P TEFC VER 286LP IEEE841 32-8 DRIP

Class - CLI GP A,B,C,D

Division - Division II

Copyright © All product information within this document is subject to ABB Motors and Mechanical Inc. copyright © protection, unless otherwise noted.

2/16/2025 11:08:25 PM

Specifications

Enclosure	TEFC
Frame	286LP
Frame Material	Iron
Frequency	60.00 Hz
Haz Area Class and Group	CLI GP A,B,C,D
Haz Area Division	Division II
Motor Letter Type	Three Phase
Output @ Frequency	30.000 HP @ 60 HZ
Phase	3
Synchronous Speed @ Frequency	1800 RPM @ 60 HZ
Voltage @ Frequency	460.0 V @ 60 HZ
Agency Approvals	CCSA US CSA EEV UR
Ambient Temperature	40 °C
Auxillary Box	No Auxillary Box
Auxillary Box Lead Termination	None
Base Indicator	No Mounting
Bearing Grease Type	Polyrex EM (-20F +300F)
Blower	None
Constant Torque Speed Range	1
Current @ Voltage	36.000 A @ 460.0 V
Design Code	B
Drip Cover	Drip Cover
Duty Rating	CONT
Efficiency @ 100% Load	93.6 %
Electrically Isolated Bearing	Not Electrically Isolated
Enclosure Modification	841
Feedback Device	NO FEEDBACK
Front Shaft Indicator	Standard
Haz Area Temp Code	T3C
Heater Indicator	No Heater

Part detail

Revision	H
Type	AC
Mech. spec.	10K389
Base	
Status	PRD/A
Elec. spec.	10WGZ438
Layout	10LYK389
Eff. date	02-29-2024
CD Diagram	CD0006
Poles	04
Leads	3#10
Proprietary	False
Created date	03-25-2019

High Voltage Full Load Amps	36.0 a
Insulation Class	F
Inverter Code	Inverter Duty
IP Rating	IP56
KVA Code	G
Lifting Lugs	Vertical Lifting Lugs
Locked Bearing Indicator	Locked Bearing
Max Speed	2700 rpm
Motor Lead Quantity/Wire Size	3 @ 10 AWG
Motor Lead Termination	Ring Terminals
Motor Standards	NEMA
Motor Type	1060M
Mounting Arrangement	V1
Number of Poles	4
Overall Length	36.31 IN
Power Factor	84
Product Family	Chem Process S/P 32-8 IEEE 841
Pulley End Bearing Type	Ball
Pulley Face Code	P-Base
Pulley Shaft Indicator	P-Base Groove & Key
Rodent Screen	None
RoHS Status	ROHS NON-COMPLIANT
Service Factor	1.15
Shaft Diameter	2.125 IN
Shaft Ground Indicator	No Shaft Grounding
Shaft Rotation	Reversible
Shaft Slinger Indicator	No Slinger
Speed	1770 rpm
Speed Code	Single Speed
Starting Method	Direct on line
Thermal Device - Bearing	None
Thermal Device - Winding	None
Vibration Sensor Indicator	No Vibration Sensor
Winding Thermal 1	None

Winding Thermal 2

None

Nameplate

NP4332

STK.NO.	VLECP84104T-4	P/N		ENCLOSURE	TEFC
SPEC.	10K389Z438G1	CC	010A	FRAME	286LP
HP	30	CLASS	F	HZ	60
RPM	1770	RPM MAX	2700	PH	3
VOLT	460	KVA-CODE	G	ODE BRG	7309
AMP	35.6	MOTOR WEIGHT	619	DE BRG	6213
RATING	40C AMB-CONT	MAX. KVAR	7.7	D.E. BRG.	65BC02X30X
NEMA-NOM-EFF	93.6	# OF ROTOR BARS	40	O.D.E. BRG.	45BT03X30X
G.MIN.EFF	92.4	# OF STATOR SLOTS	48	BLANK	
TEMP CODE	T3	PF	84	INV.TYPE	PWM
TEMP =	200	SER.F.	1.15	IP	56
CT HZ FROM	30	INVERTER-TEMP-CODE	200	C HP FR	60
HTR-VOLTS		C HP TO	90	HTR-AMPS	
		CT HZ TO	60	HTR-WATTS	
		HTR-VOLTS		MAX. SPACE HEATER TEMP.	
				VT HZ FROM	30
				VT HZ TO	60

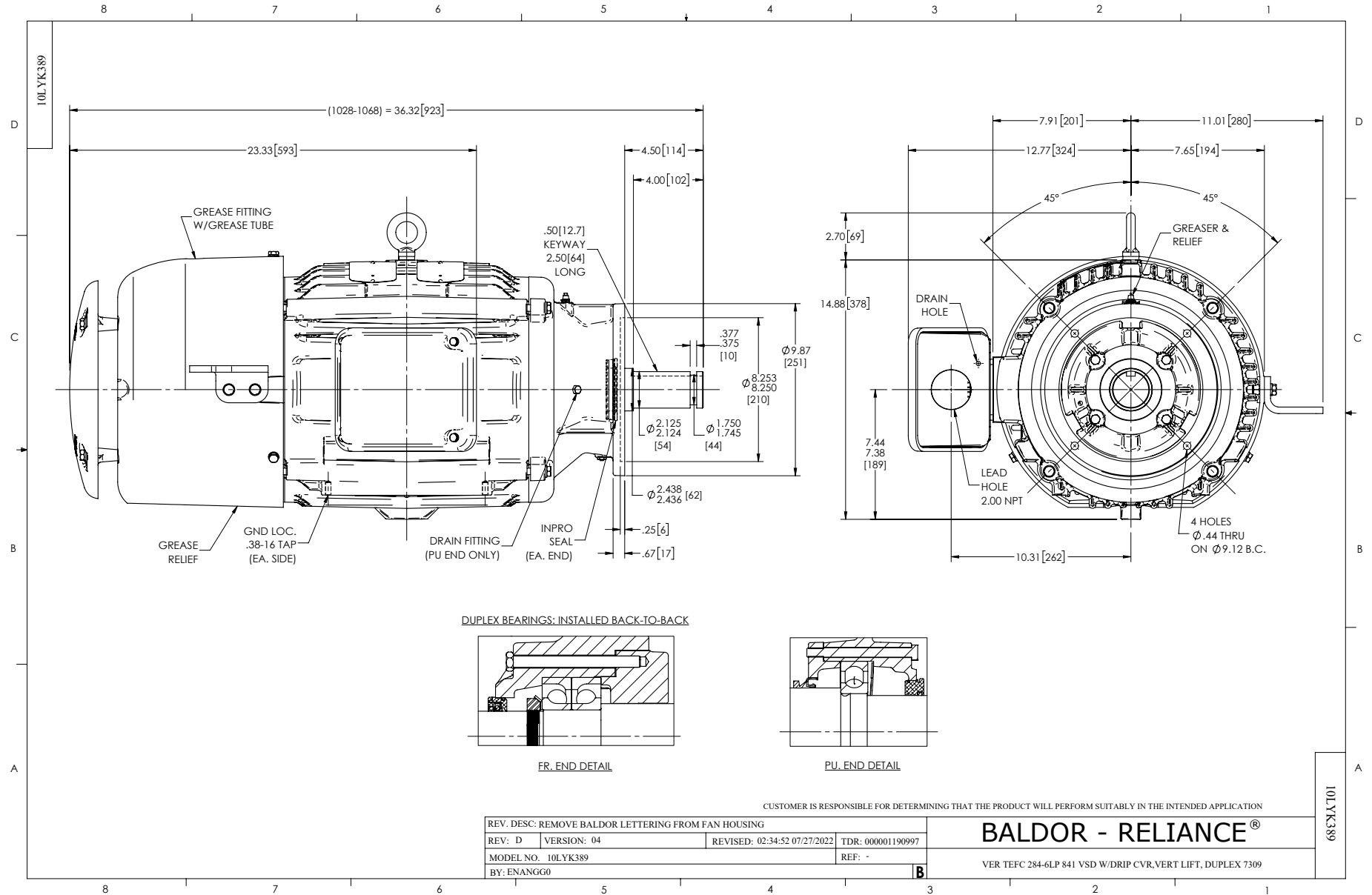

CD0006

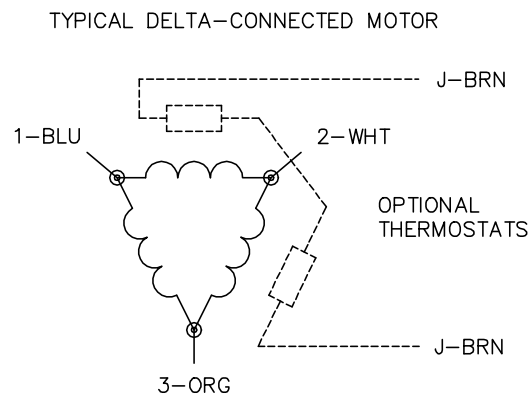
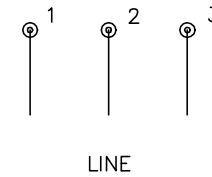
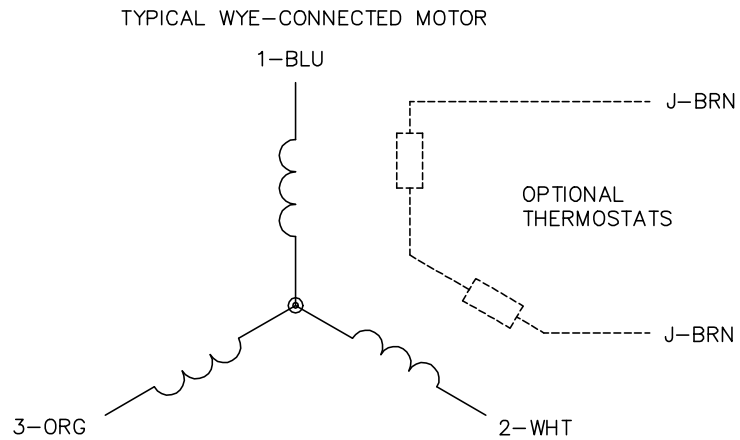

NOTES:

1. THREE LEAD MOTOR MAY BE EITHER WYE CONNECTED OR DELTA CONNECTED.
2. INTERCHANGE ANY TWO LINE LEADS TO REVERSE ROTATION.
3. OPTIONAL THERMOSTATS ARE PROVIDED WHEN SPECIFIED.
4. ACTUAL NUMBER OF INTERNAL PARALLEL CIRCUITS MAY VARY.
5. LEAD COLORS ARE OPTIONAL. LEADS MUST BE NUMBERED AS SHOWN.

CD0006

REV. DESC: ADD CLASS CONN00000007		
REV. LTR: E	VERSION: 01	TDR: 000001099922
FILE: \AAA\00005\141	REVISED: 10:24:49 02/19/2019	BY: ENBRIRO
MTL: -	© □	

BALDOR - RELIANCE®

3PH, SV, 3 LEADS, WYE OR DELTA CONNECTED

SH 1 of 1