

To Protect Your Warranty, Use Only ENERPAC Hydraulic Oil.

Enerpac recommends that all kit components be installed to insure optimum performance of the repaired product.

Key:

- A. Hydraulic Pressure Gauge (see figure 1)
- B. Manifold / Valve Station (see figure 2)
- C. Hydraulic Oil Fill Plug (see figure 3)
- D. Pump Assembly (see figure 4)
- E. Oil Filter Assembly (see figure 5)
- F. Shuttle Valve Assembly (see figure 6)
- G. Air On-Off Switch Assembly (see figure 7)
- H. Filter / Regulator (see figure 8)
- I. Air On-Off Switch (see figure 9)

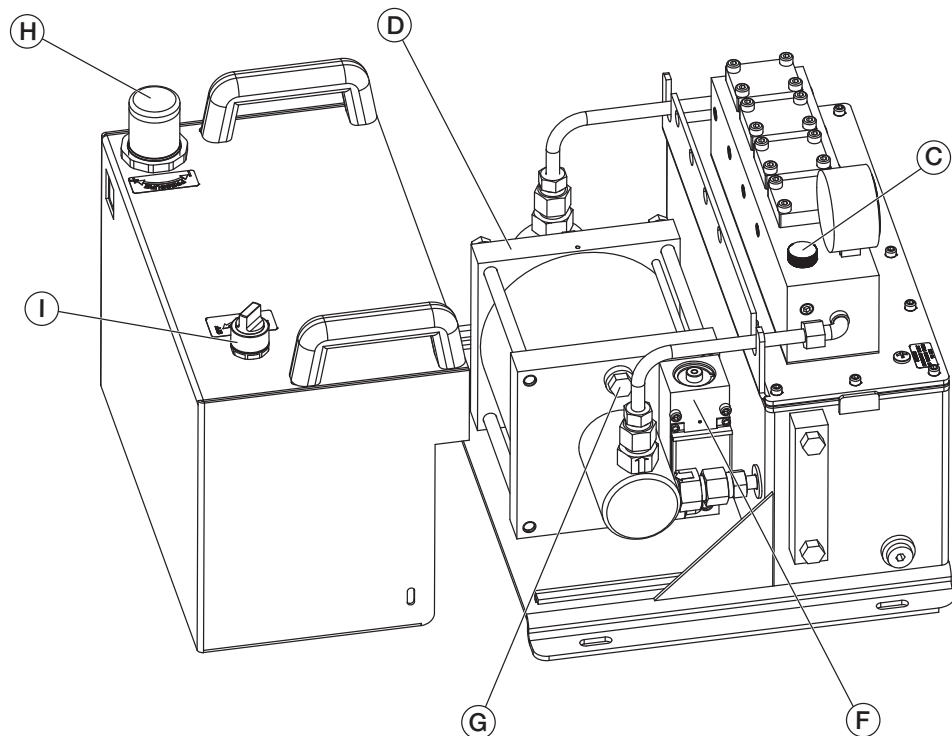
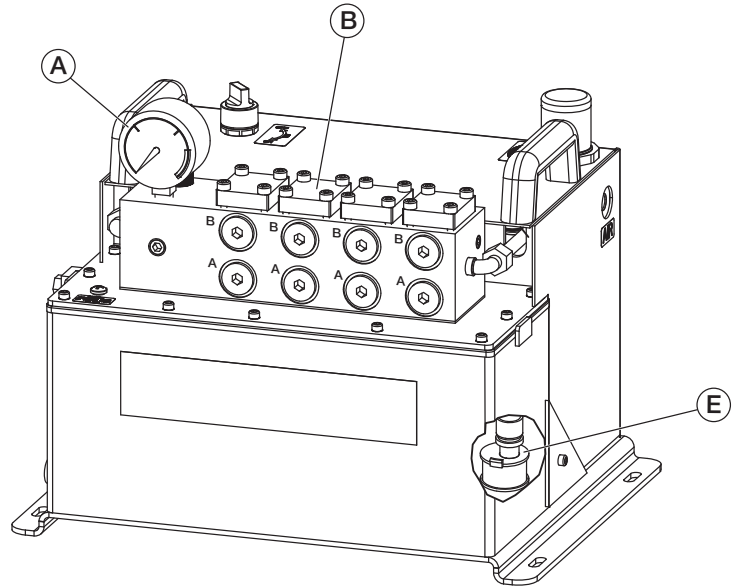
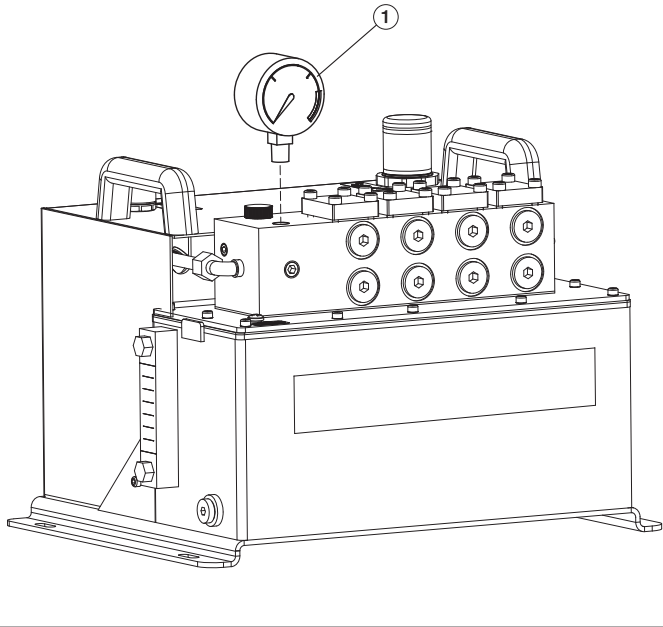

Figure 1 - Hydraulic Pressure Gauge



Parts List for Figure 1

Item	Part Number	Qty.	Description
1	G2517L	1	Hydraulic Pressure Gauge

Notes:

Apply Teflon tape to threads of gauge.

Torque 1.5 to 3 turns after hand tight, 34 Nm max. [25 ft-lbs].

Figure 2 - Manifold / Valve Station

Notes:

 Torque to 8-10 Nm [6-8 ft-lbs].

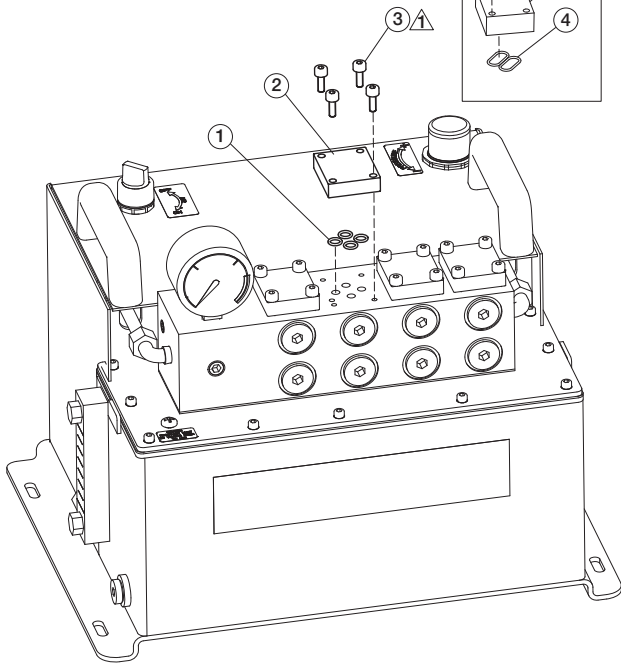
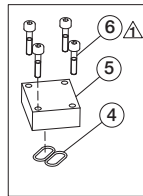

Parts List for Figure 2

Item	Part Number	Qty.	Description
1	◆	4	O-Ring (-012)
2	◆	1	Cover Plate, D03
3	◆	4	Socket Hd Cap Screw, #10-24 x 7/8" long
4	❖	2	O-Ring (-016)
5	❖	1	Cross Over plate
6	❖	4	Socket Hd Cap Screw, #10-24 x 1" long

◆ Included in MC1 Cover plate Kit.

❖ Included in MC2 Cross Over Plate Kit.

Figure 3 - Hydraulic Oil Fill Plug

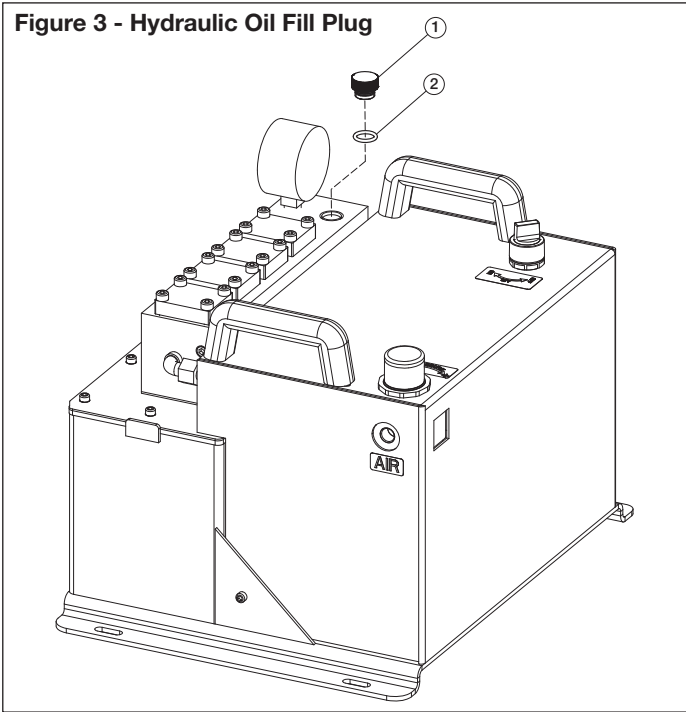

Parts List for Figure 3

Item	Part Number	Qty.	Description
1	DW1700900SR	1	Plug
2		1	O-Ring

Figure 4 - Pump Assembly

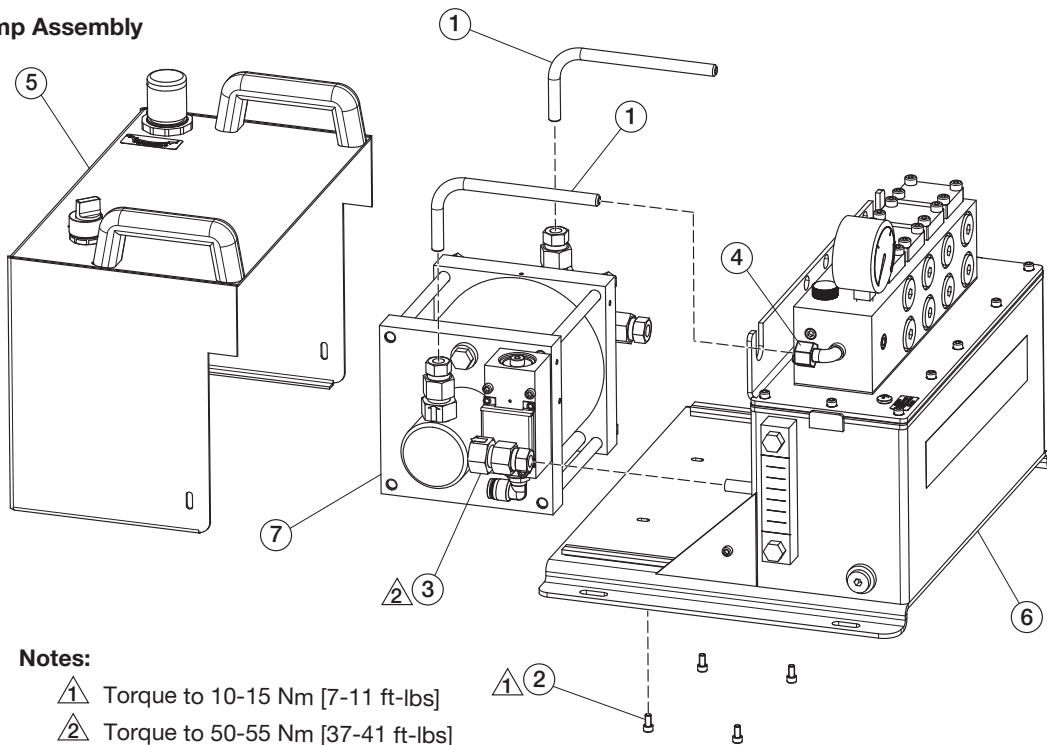

Parts List for Figure 4

Item	Part Number	Qty.	Description	Item	Part Number	Qty.	Description
1	---	2	Pipe-Elbow	6	---	1	Tank Assembly
2	---	4	Bolt M5-0.8 x 10 mm LG	7▲	DX7025900SR	1	Pump Assembly, 70 bar
3	---	2	Connector		DX7026900SR	1	Pump Assembly, 150 bar
4	---	2	Connector		DX7027900SR	1	Pump Assembly, 300 bar
5	---	1	Cover Assembly	▲ Refer to L4241 to identify pump element seal kit			

Figure 5 - Oil Filter Assembly

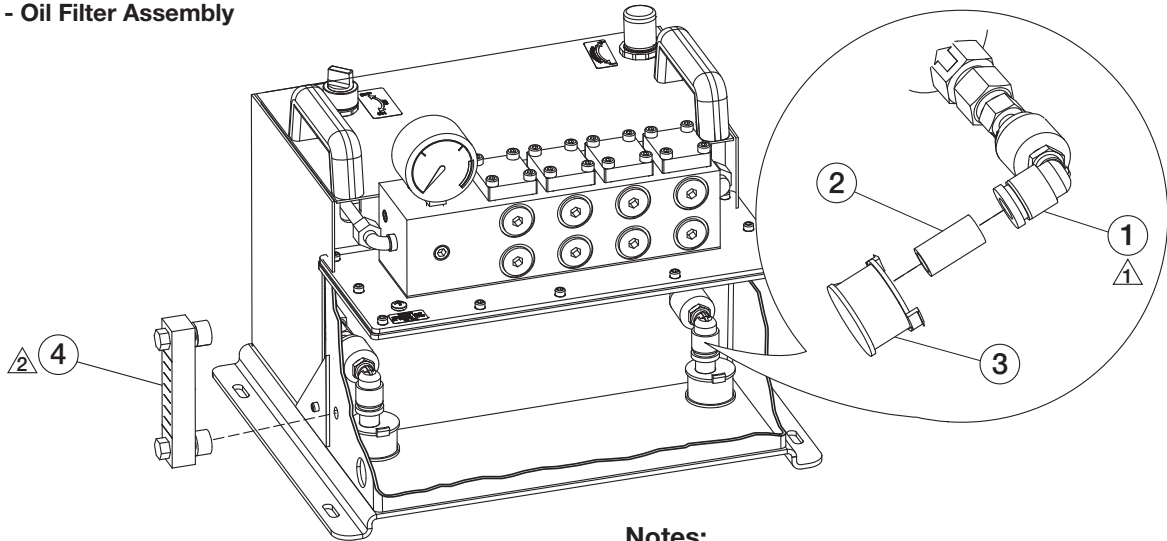

Notes:

- ⚠ Torque to 6-8 ft-lbs [8-10 Nm].
- ⚡ Tighten bolts snug tight.

Parts List for Figure 5

Item	Part Number	Qty.	Description
1	---	2	Connector
2	---	2	Adapter
3	DC9178118	2	Oil Filter (Suction Strainer)
4	■	1	Oil Level Gauge
■ Included in DD1367223SR Service Level Kit.			

Figure 6 - Shuttle Valve Assembly

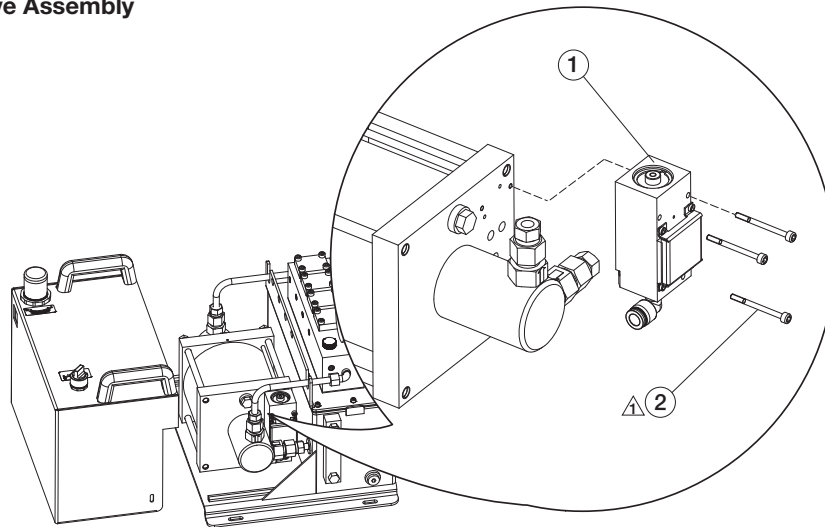

Notes:

- ⚠ Torque to 3-5 ft-lbs [5-7 Nm].

Parts List for Figure 6

Item	Part Number	Qty.	Description
1	DX7040900SR	1	Air Shuttle Valve Assembly
2	---	3	Bolt, M4 x 0.7 x 50 mm Lg. (included with item 1)

Figure 7 - Air On-Off Switch Assembly

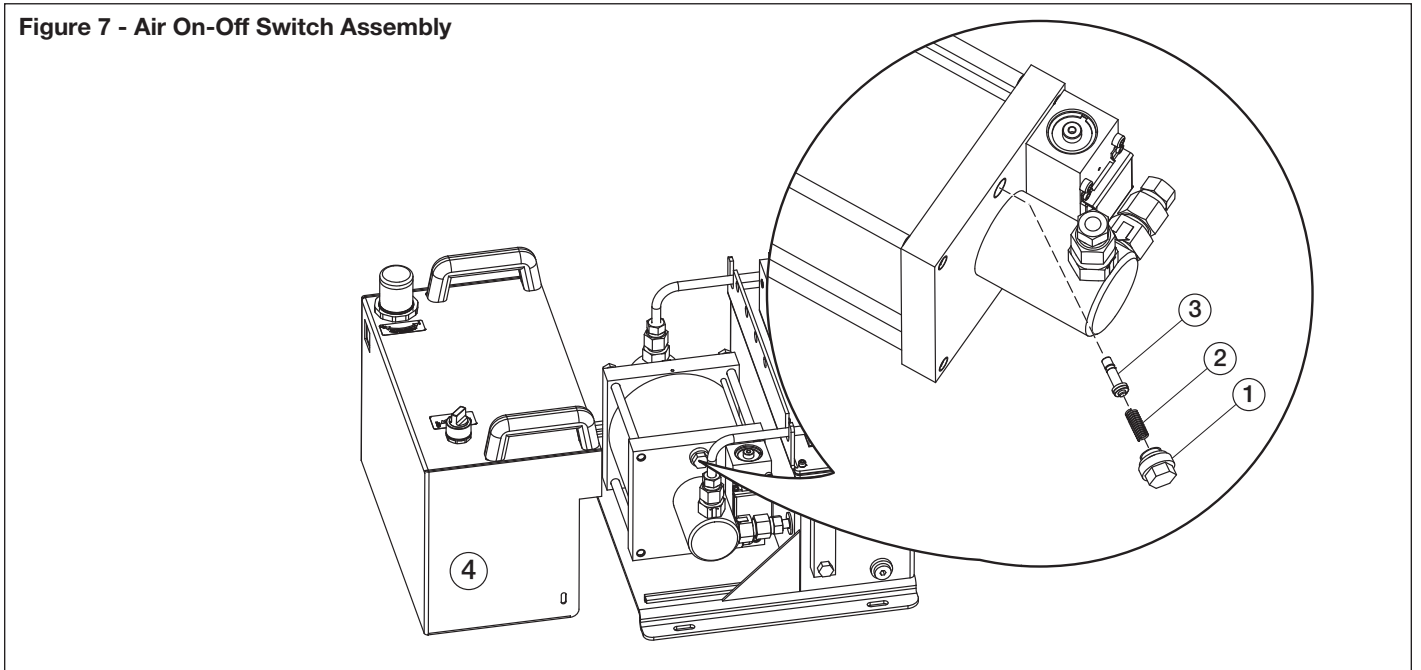

Parts List for Figure 7			
Item	Part Number	Qty.	Description
1	★	1	Cap Assembly
2	★	1	Coil Spring
3	★	1	Piston Assembly
★ Included in DX7058900SR Air Switch Assembly			

Figure 8 - Filter / Regulator

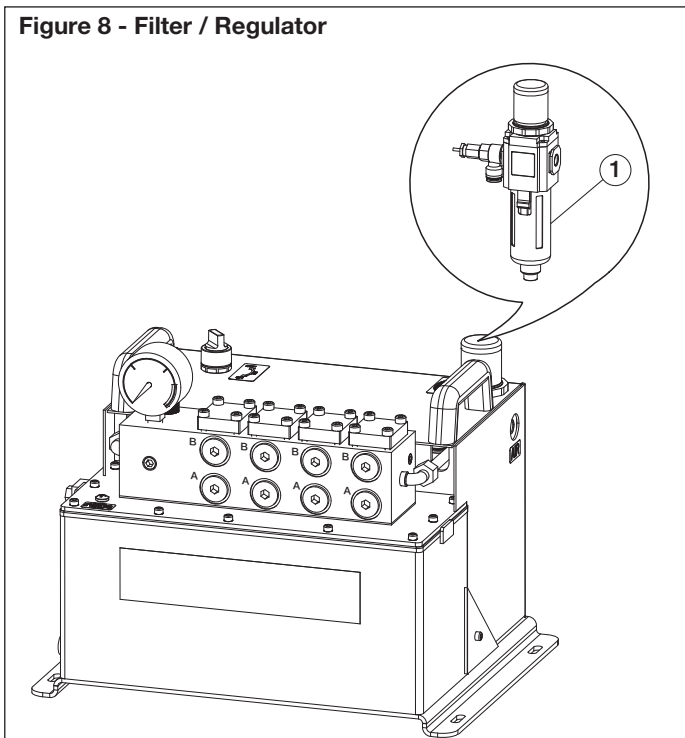

Parts List for Figure 8			
Item	Part Number	Qty.	Description
1	DX9070118	1	Filter/Regulator Assembly
Notes: Pneumatic fittings NOT included with new filter/regulator.			

Figure 9 - Air On-Off Switch

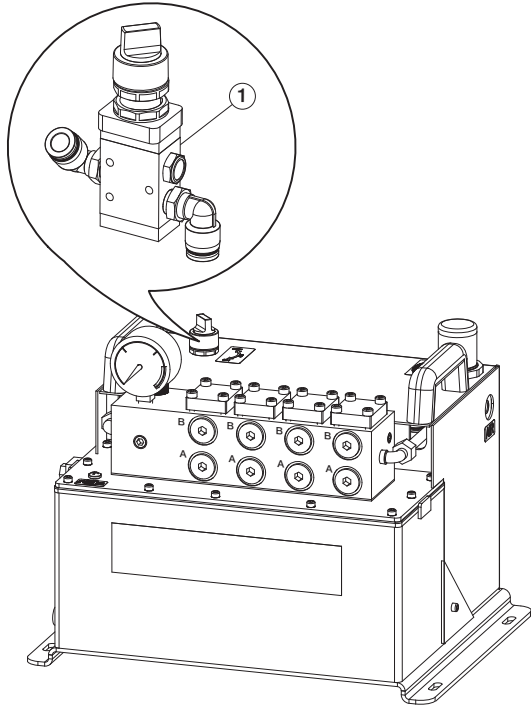

Parts List for Figure 9

Item	Part Number	Qty.	Description
1	DX9044660	1	Air On-Off Switch Assembly

Notes:

Pneumatic fittings NOT included with new air on-off switch.

NOTES



www.enerpac.com