

Hub City™ Worm Gear Drives

Double Reduction

GW Series Catalog Ratings

Series GW60D & GW70D

SERIES	INPUT RPM	RATIO	OUTPUT RPM	MECH. INPUT HP	CONVENTIONAL OIL		PAO SYNTHETIC OIL		PAG SYNTHETIC OIL	
					EFF. %	MECH. OUTPUT TORQUE	EFF. %	MECH. OUTPUT TORQUE	EFF. %	MECH. OUTPUT TORQUE
GW60D	1750	75	23.1	9.10	78.4	19271	80.4	19753	81.9	20138
		100	16.5	8.67	68.6	21417	70.3	21952	71.7	22381
		150	11.4	5.95	73.3	23471	75.1	24058	76.6	24527
		200	8.54	4.95	69.0	24607	70.7	25222	72.1	25714
		250	7.14	4.25	64.9	24841	66.5	25462	67.8	25959
		300	5.69	3.61	65.9	25821	67.5	26467	68.8	26983
		400	4.27	3.01	61.4	26473	63.0	27135	64.2	27664
		500	3.41	2.52	59.3	26872	60.8	27544	62.0	28081
		600	2.85	2.24	55.7	27151	57.1	27830	58.2	28373
		750	2.38	1.93	51.8	27386	53.1	28071	54.1	28618
		900	1.98	1.62	51.0	27434	52.3	28120	53.3	28669
		1000	1.75	1.61	49.2	27737	50.4	28430	51.4	28985
		1200	1.42	1.40	47.0	27683	48.1	28375	49.1	28929
		1500	1.19	1.24	43.1	28088	44.2	28790	45.1	29352
		1800	0.99	1.00	40.1	25273	41.1	25905	41.9	26410
		2400	0.73	0.84	36.9	27893	37.9	28590	38.6	29148
		3000	0.58	0.75	34.0	26792	34.9	27462	35.5	27998
3600	0.49	0.65	28.0	23067	28.7	23644	29.3	24105		
GW70D	1750	75	23.1	9.13	82.7	20601	84.8	21116	86.4	21528
		100	16.5	9.13	79.1	27535	81.1	28223	82.6	28774
		150	11.4	7.25	76.3	30621	78.2	31387	79.7	31999
		200	8.54	5.81	74.4	31857	76.2	32653	77.7	33291
		250	7.14	4.90	72.2	31238	74.1	32019	75.5	32644
		300	5.69	4.27	70.0	33136	71.8	33964	73.2	34627
		400	4.27	3.41	67.2	33805	68.8	34650	70.2	35326
		500	3.41	2.86	64.7	34209	66.3	35064	67.6	35748
		600	2.85	2.53	61.7	34477	63.2	35339	64.4	36028
		750	2.38	2.13	59.6	33682	61.1	34524	62.3	35198
		900	1.98	1.73	58.4	32016	59.8	32816	61.0	33457
		1000	1.75	1.73	54.9	35031	56.2	35907	57.3	36607
		1200	1.42	1.52	52.2	35168	53.5	36047	54.6	36751
		1500	1.19	1.28	50.6	34325	51.9	35183	52.9	35870
		1800	0.99	1.04	49.1	32580	50.4	33395	51.3	34046
		2400	0.73	0.90	43.3	33661	44.4	34503	45.2	35176
		3000	0.58	0.76	39.7	32512	40.7	33325	41.5	33975
3600	0.49	0.60	37.8	29307	38.7	30040	39.5	30626		

OVERHUNG LOAD AND THRUST LOAD INFORMATION

NOTE: ALL TORQUE VALUES LISTED IN INCH-POUNDS, ALL OVERHUNG LOAD VALUES LISTED IN POUNDS. THE POINT OF APPLICATION OF THE OVERHUNG LOAD IS CONSIDERED TO BE ONE SHAFT DIAMETER MEASURED OUTWARD FROM THE GEAR CASE HOUSING. AT SPEEDS ABOVE 1750 RPM, UNITS MAY BECOME THERMALLY LIMITED. FOR EXTENDED OPERATION, LIMIT INPUT HP TO 1750 RPM CATALOG RATING.

THRUST AND OVERHUNG LOAD RATINGS (LBS.)	GW60D	GW70D
Thrust Load Ratings (Low Speed Shaft, All Ratios)	3990	4009
Overhung Load Capacity* (High Speed Shaft, All Ratios)	150	150
Overhung Load Capacity* (Low Speed Shaft, All Ratios)	3723	6209
Overhung Load Capacity** (Extended Brg Design Output Shaft, All Ratios)	2245	3791

ADDITIONAL RATINGS FOR OTHER INPUT SPEEDS ARE AVAILABLE AT: WWW.HUBCITYINC.COM

* OHL AND THRUST VALUES SHOWN ARE INDEPENDENT FUNCTIONS AND CANNOT BE APPLIED SIMULTANEOUSLY. REFER APPLICATIONS WITH COMBINED OHL AND THRUST TO REGAL CUSTOMER SERVICE DEPARTMENT.

* THE POINT OF APPLICATION OF THE OVERHUNG LOAD IS CONSIDERED TO BE ONE SHAFT DIAMETER MEASURED OUTWARD FROM THE GEARCASE HOUSING.

**LOAD LOCATED AT END OF OUTPUT SHAFT.

OUTPUT TORQUE VALUES SHOWN ARE INCH-POUNDS (IN-LB).

Hub City™ Worm Gear Drives

Double Reduction Models

1304, 1504, 1804, 2104, 2404, 2604, 3004, 3204, 3804, 4204, 4504, 5204, GW6004, GW7004, GW8004, GW10004

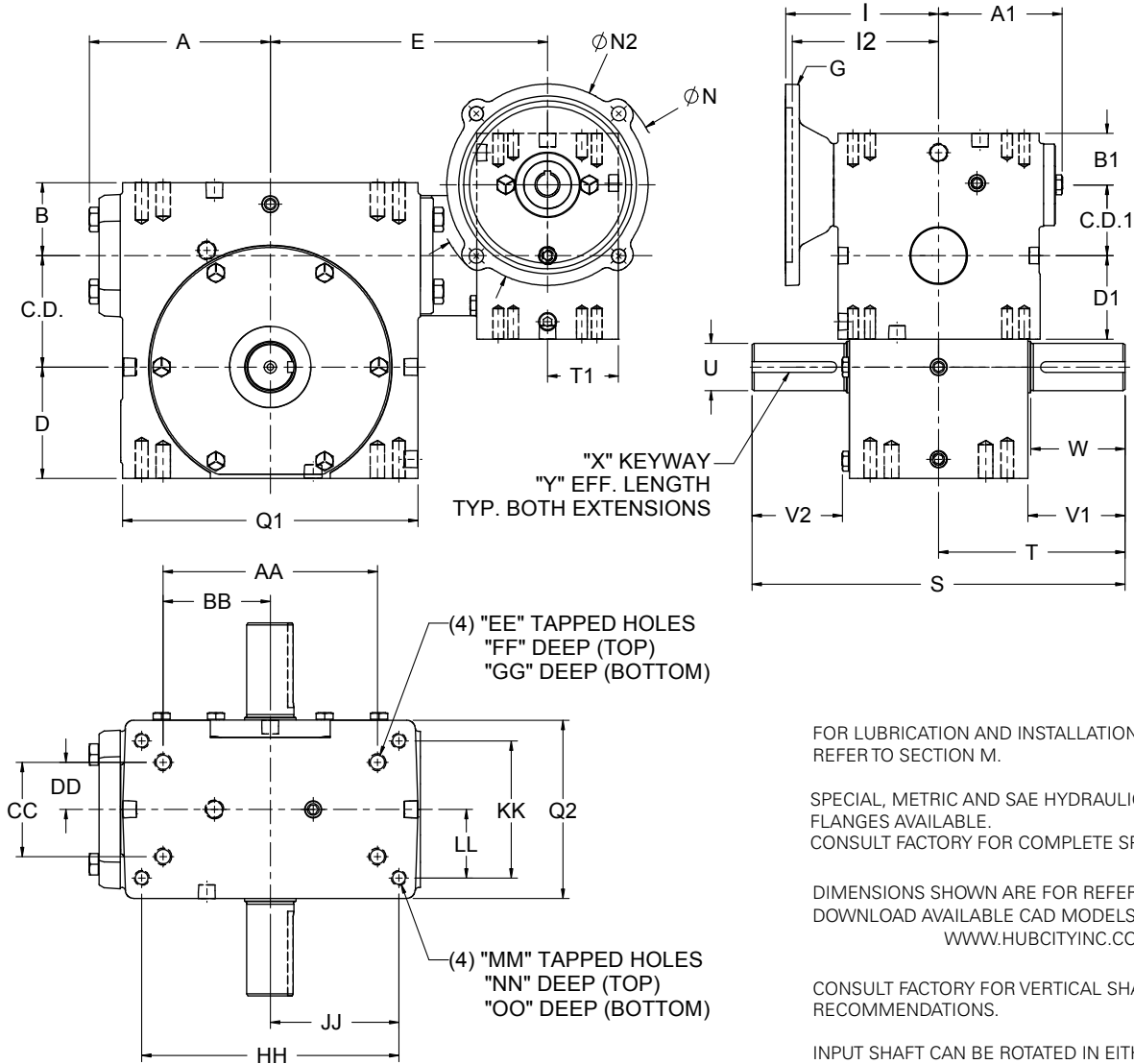

Standard Styles Available

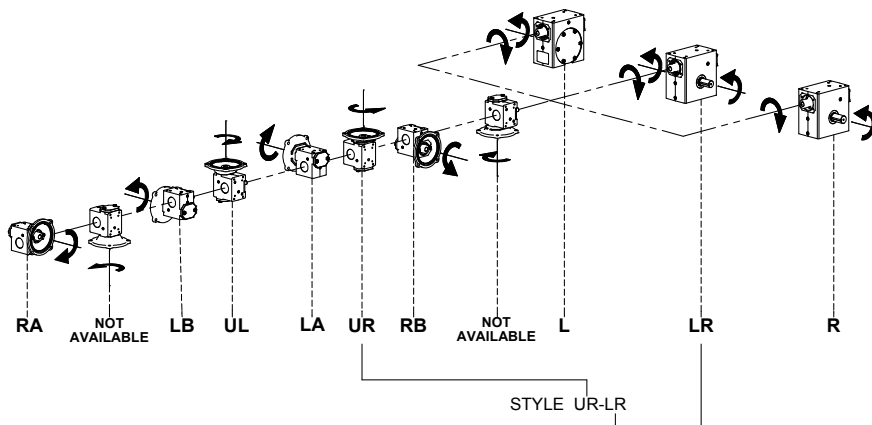

Hub City™ Worm Gear Drives

Double Reduction Models

1304, 1504, 1804, 2104, 2404, 2604, 3004, 3204, 3804, 4204, 4504, 5204, GW6004, GW7004, GW8004, GW10004

MODEL	PRIMARY	SECONDARY	C.D.	A	B	D	Q1	Q2	E	T1	C.D.1	A1	B1	D1	S	T
1304	134	134-56C	1.334	2.61	1.186	1.562	4.12	3.12	4.87	1.56	1.334	2.61	1.186	1.562	6.50	3.25
1504	GW134	154	1.541	3.14	1.928	1.906	4.88	3.44	5.85	1.84	1.334	2.61	1.610	1.720	8.62	4.31
1804	134	184-56C	1.751	3.23	1.374	1.875	5.16	3.44	5.50	1.56	1.334	2.61	1.186	1.562	7.00	3.50
2104	134	214-56C	2.064	3.61	1.500	2.437	5.88	4.12	5.87	1.56	1.334	2.61	1.186	1.562	8.50	4.25
2404	GW134	244	2.376	3.77	2.061	2.500	6.12	4.06	6.44	1.84	1.334	2.61	1.610	1.720	10.28	5.14
2604	134	264-56C	2.626	4.33	1.874	2.938	7.20	4.50	6.58	1.56	1.334	2.61	1.186	1.562	9.00	4.50
3004	GW184	304	3.001	4.84	2.624	3.250	8.12	5.25	7.86	1.78	1.750	3.24	1.940	2.060	13.50	6.75
3204	214	324-143TC	3.251	5.28	2.124	3.250	8.62	5.20	8.09	2.06	2.064	3.61	1.500	2.437	10.88	5.44
3804	214	384-143TC	3.751	4.90	2.374	3.937	9.60	5.62	8.61	2.06	2.064	3.61	1.500	2.437	13.38	6.69
4204	GW214	424	4.251	6.10	2.686	4.438	10.25	6.13	9.18	1.91	2.060	3.61	2.020	2.280	16.24	8.12
4504	324	454-213TC	4.501	5.23	2.499	4.625	9.25	4.63	9.14	2.60	3.251	5.28	2.124	3.250	14.50	7.25
5204	324	524-213TC	5.168	5.98	2.624	5.375	10.75	5.06	9.89	2.60	3.251	5.28	2.124	3.250	15.62	7.81
GW6004	GW324	GW601	6.000	N/A	4.000	6.500	14.25	8.13	13.30	2.88	3.250	5.02	2.630	3.500	20.00	10.00
GW7004	GW324	GW701	7.000	N/A	4.320	7.590	14.88	7.63	12.96	2.88	3.250	5.02	2.630	3.500	23.52	11.76
GW8004	GW424	GW801	8.000	N/A	4.100	8.860	17.00	8.63	13.94	3.07	4.250	6.10	2.690	4.440	24.50	12.25
GW10004	GW454	GW1001	10.000	N/A	5.110	10.360	20.88	9.53	17.05	3.60	5.250	7.50	3.630	5.120	29.50	14.75

MODEL	U	V1	V2	W	X	Y
1304	.625/.624	1.69	1.53	1.60	3/16 X 3/32	1.38
1504	.750/.7485	2.11	1.90	2.08	3/16 X 3/32	1.51
1804	.750/.749	1.78	1.57	1.54	3/16 X 3/32	1.41
2104	.875/.874	2.19	1.98	1.95	3/16 X 3/32	1.83
2404	1.125/1.1235	2.66	2.44	2.62	1/4 X 1/8	1.76
2604	1.250/1.249	2.25	2.04	N/A	1/4 X 1/8	1.85
3004	1.250/1.2485	3.60	3.36	3.57	1/4 X 1/8	2.26
3204	1.375/1.374	2.84	2.62	2.75	5/16 X 5/32	2.31
3804	1.500/1.499	3.88	N/A	N/A	3/8 X 3/16	3.16

MODEL	U	V1	V2	W	X	Y
4204	1.875/1.8735	4.50	4.21	4.47	1/2 X 1/4	3.06
4504**	1.625/1.624	4.18	N/A	3.90	3/8 X 3/16	3.28
5204***	1.750/1.749	4.47	N/A	4.17	3/8 X 3/16	3.50
GW6004	2.500	4.65	4.65	N/A	5/8 X 5/16 P&W	4.00
GW7004	2.750	5.65	5.65	N/A	5/8 X 5/16 P&W	4.00
GW8004	3.000	5.98	5.98	5.26	3/4 X 3/8 P&W	4.50
GW10004	3.750	6.76	6.76	6.39	7/8 X 7/16 P&W	5.00

** ALSO AVAILABLE WITH 1.750/1.749 (U) DIAMETER OUTPUT SHAFT. CONSULT FACTORY.

*** ALSO AVAILABLE WITH 2.000/1.999 (U) DIAMETER OUTPUT SHAFT. CONSULT FACTORY.

MODEL	AA	BB	CC	DD	EE	FF	GG	HH	JJ	KK	LL	MM	NN	OO	WT. LBS.
1304	2.250	1.125	1.625	0.813	1/4 UNC	0.50	0.50	3.250	1.625	2.000	1.000	5/16 UNC	0.50	0.50	22
1504	4.188	2.094	2.750	1.375	5/16 UNC	0.63	0.63	N/A	N/A	N/A	N/A	N/A	N/A	N/A	26
1804	3.125	1.563	1.625	0.813	1/4 UNC	0.50	0.50	4.188	2.094	2.750	1.375	5/16 UNC	0.63	0.63	26
2104	4.000	2.000	2.000	1.000	3/8 UNC	0.50	0.70	5.000	2.500	2.875	1.438	3/8 UNC	0.70	0.70	36
2404	5.000	2.500	2.875	1.438	3/8 UNC	0.69	0.69	N/A	N/A	N/A	N/A	N/A	N/A	N/A	52
2604	4.875	2.438	2.688	1.344	3/8 UNC	0.70	0.70	6.375	3.188	3.375	1.688	3/8 UNC	0.70	0.70	48
3004	7.000	3.500	4.000	2.000	7/16 UNC	0.88	0.88	N/A	N/A	N/A	N/A	N/A	N/A	N/A	81
3204	6.250	3.125	2.750	1.375	1/2 UNC	0.75	0.75	7.500	3.750	4.000	2.000	7/16 UNC	0.88	0.88	85
3804	6.875	3.438	3.000	1.500	1/2 UNC	0.94	1.00	8.500	4.250	4.750	2.375	1/2 UNC	1.00	1.00	115
4204	8.500	4.250	5.000	2.500	5/8 UNC	1.00	1.00	N/A	N/A	N/A	N/A	N/A	N/A	N/A	135
4504	8.125	4.063	3.250	1.625	5/8 UNC	0.88	1.13	N/A	N/A	N/A	N/A	N/A	N/A	N/A	176
5204	9.500	4.750	3.750	1.875	5/8 UNC	1.00	1.25	N/A	N/A	N/A	N/A	N/A	N/A	N/A	202
GW6004	12.750	6.375	6.380	3.190	5/8 UNC	1.00	1.00	N/A	N/A	N/A	N/A	N/A	N/A	N/A	406
GW7004	12.500	6.250	5.500	2.750	1 UNC	1.56	1.56	N/A	N/A	N/A	N/A	N/A	N/A	N/A	482
GW8004	14.250	7.125	6.500	3.250	1 UNC	1.66	1.66	N/A	N/A	N/A	N/A	N/A	N/A	N/A	728
GW10004	17.750	8.875	6.875	3.438	1-1/4 UNC	2.04	2.04	N/A	N/A	N/A	N/A	N/A	N/A	N/A	1151

MODEL	G	I	I2	N	N2
1304	48CZ	3.46	N/A	4.36	3.87
	56C			6.63	6.50
1504	48CZ	3.46	N/A	4.36	3.87
	56C			6.63	6.50
1804	48CZ	3.46	N/A	4.36	3.87
	56C			6.63	6.50
2104	48CZ	3.46	N/A	4.36	3.87
	56C			6.63	6.50
2404	48CZ	3.46	N/A	4.36	3.87
	56C			6.63	6.50
2604	48CZ	3.46	N/A	4.36	3.87
	56C			6.63	6.50
3004	48CZ	4.09	N/A	4.36	3.87
	56C			6.63	6.50
	143TC			6.63	6.50

MODEL	G	I	I2	N	N2
3204	48CZ	4.46	N/A	4.36	3.87
	56C			6.63	6.50
3804	143TC				
	48CZ	4.46	N/A	4.36	3.87
56C	6.63			6.50	
4204	143TC				
	48CZ	4.46	N/A	4.36	3.87
56C	6.63			6.50	
4504	143TC				
	56C	6.14	N/A	6.50	6.50
143TC					
5204	182TC	N/A	6.34	9.00	9.00
	213TC				
5204	56C	6.14	N/A	6.50	6.50
	143TC				
5204	182TC	N/A	6.34	9.00	9.00
	213TC				

MODEL	G	I	I2	N	N2
GW6004	56C	6.14	N/A	6.50	6.50
	143TC				
	182TC	N/A	6.34	9.00	9.00
213TC	6.90				
GW7004	56C	6.14	N/A	6.50	6.50
	143TC				
	182TC	N/A	6.34	9.00	9.00
213TC	6.90				
GW8004	56C	6.45	N/A	6.50	6.50
	143TC				
	182TC	N/A	7.21	9.00	9.00
	213TC				
254TC					
GW10004	56C	7.85	N/A	6.50	6.50
	143TC				
	182TC	N/A	8.61	9.00	9.00
	213TC				
	254TC	N/A	9.17		