



The Timken Company

4500 Mt Pleasant St. NW

N. Canton, OH 44720

Phone: (234) 262-3000

E-Mail: CustomerCAD@timken.com • **Web site:** www.timken.com

Part Number QAPF20A315S, Single Concentric Four-Bolt Pillow Block

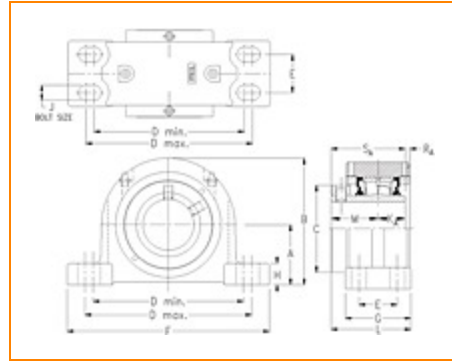
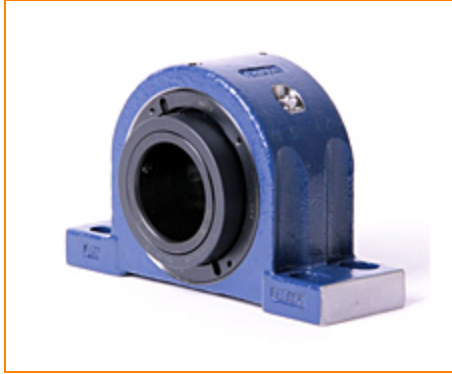

[Specifications](#) | [Dimensions](#) | [Radial and Thrust Factors](#) | [Engineering Seal Speed](#) | [Engineering Bearing Attributes](#) | [Engineering Internal Radial Clearance](#)

Specifications

Engineering Group Mounted Bearing

Bearing Number 22220

Shaft Size 3 15/16 in

Shaft Size Type Imperial

Full Timken Part Number

- QAPF20A315SB
- QAPF20A315SC
- QAPF20A315SEB
- QAPF20A315SEC
- QAPF20A315SEM
- QAPF20A315SEN
- QAPF20A315SEO
- QAPF20A315SET
- QAPF20A315SM
- QAPF20A315SN
- QAPF20A315SO
- QAPF20A315ST



Locking Style	Single Concentric
Housing Construction	Four-Bolt Pillow Block
UPC Code	0883450046701 0883450046718 0883450046732 0883450046749 0883450046756 0883450046763 0883450046770 0883450046787 0883450189354 0883450189460 0883450266697 0883450266802

Dimensions

Dimension A	4-1/4 in 108 mm
Dimension B	8.78 in 223 mm
Dimension C	6 in 152.4 mm
Dimension D Min	10.88 in 276.4 mm
Dimension D Max	13.38 in 339.9 mm
Dimension E	2-1/4 in 57.2 mm
Dimension F	14.88 in 378 mm
Dimension G	4.31 in 109.5 mm

Dimension H	1.4 in 35.6 mm
--------------------	-------------------

Dimension J (Bolt Size)	0.75 in 20 mm
--------------------------------	------------------

Dimension KA	1.63 in 41.4 mm
---------------------	--------------------

Dimension L	5.13 in 130.3 mm
--------------------	---------------------

Dimension M	2.97 in 75.4 mm
--------------------	--------------------

Dimension RA	0.35 in 8.9 mm
---------------------	-------------------

Dimension SA	4.59 in 116.6 mm
---------------------	---------------------

Radial and Thrust Factors

C0 - Static Load	113000 lbf 502000 N
-------------------------	------------------------

C - Dynamic Load (Basic)	97700 lbf 435000 N
---------------------------------	-----------------------

e - Geometry Factor	0.24
----------------------------	------

Y1 - Geometry Factor	2.85
-----------------------------	------

Y2 - Geometry Factor	4.24
-----------------------------	------

Engineering Seal Speed

Oil Lubrication - M/N Seal	1200 rpm
-----------------------------------	----------

Oil Lubrication - T Seal	2000 rpm
---------------------------------	----------

Oil Lubrication - B/C/O Seal	900 rpm
-------------------------------------	---------

Grease Lubrication - M/N Seal	1200 rpm
--------------------------------------	----------

Grease Lubrication - T Seal	1600 rpm
------------------------------------	----------

Grease Lubrication - B/C/O Seal	900 rpm
--	---------

Engineering Bearing Attributes

Float	0.083 in
	2.108 mm

Shaft Tolerance	0.0030 in
	0.076 mm

Engineering Internal Radial Clearance

Eng Internal Radial Clearance - Min	0.0030
--	--------

Eng Internal Radial Clearance - Max	0.0047
--	--------

Pre Install Clearance Min	0.0030 in
	0.075 mm

Pre Install Clearance Max	0.0047 in
	0.120 mm

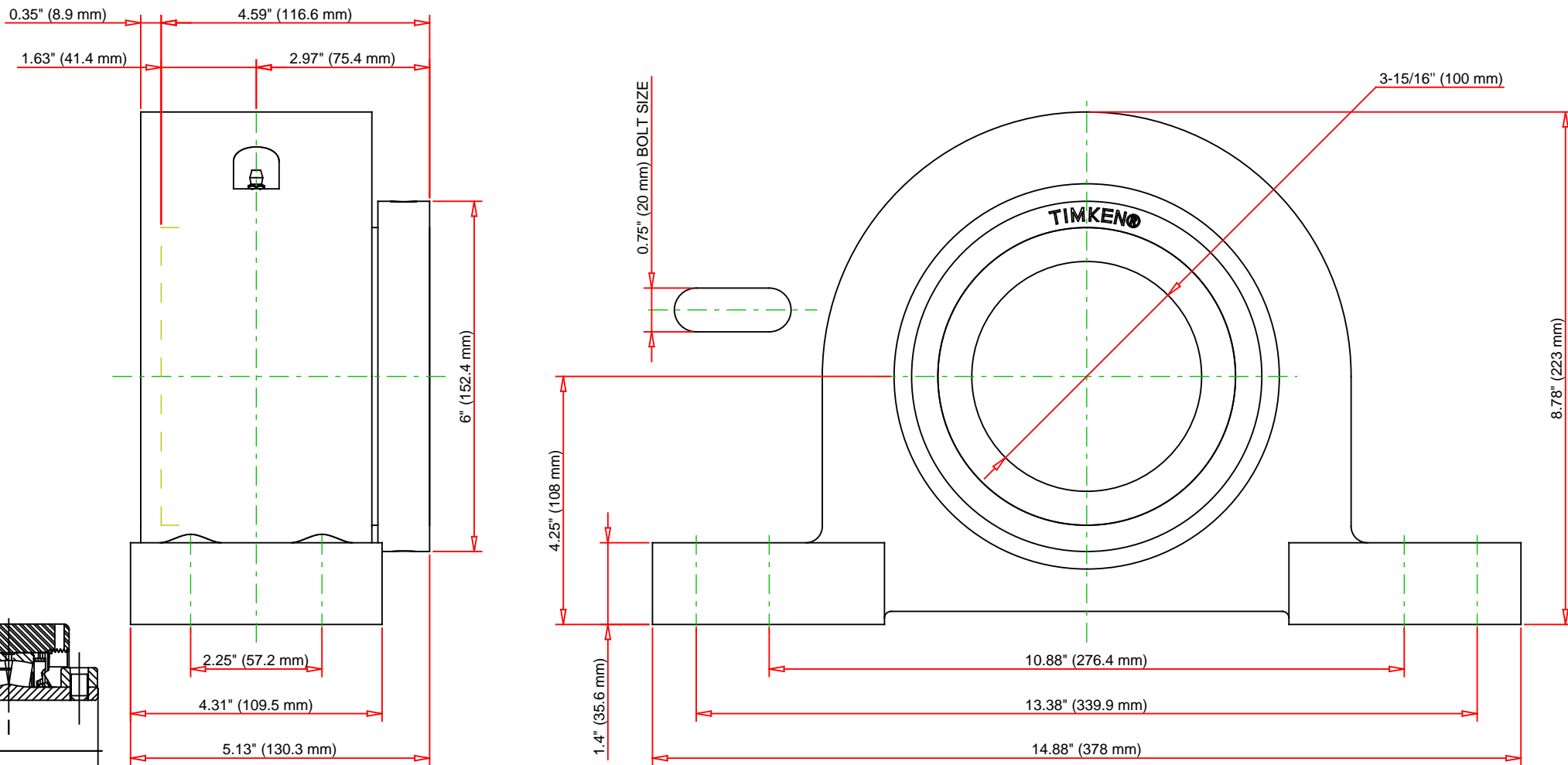

Note: Section View not to Scale

C - Dynamic Load	97700	lbf	435000	N
C0 - Static Load	113000	lbf	502000	N
Weight	67	lb	30.4	kg
Max. Speed T-Seals & Grease	1600	rpm		
Rad. Clearance - Max.	0.0047			

TIMKEN

THE TIMKEN COMPANY
NORTH CANTON, OHIO USA

QAPF20A315S

Single Concentric Four-Bolt Pillow Block

Every reasonable effort has been made to ensure the accuracy of the information contained in this writing, but no liability is accepted for errors, omissions or for any other reason.

FOR DISCUSSION ONLY