



The Timken Company

4500 Mt Pleasant St. NW

N. Canton, OH 44720

Phone: (234) 262-3000

E-Mail: CustomerCAD@timken.com • **Web site:** www.timken.com

Part Number QATP18A304S, Single Concentric Top Pull Take-Up Block

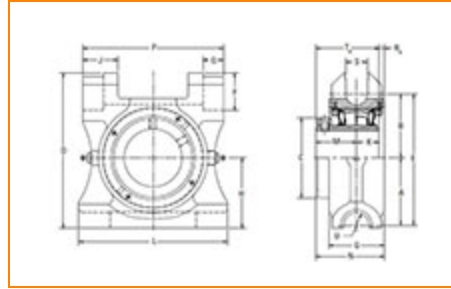

[Specifications](#) | [Dimensions](#) | [Radial and Thrust Factors](#) | [Engineering Seal Speed](#) | [Engineering Bearing Attributes](#) | [Engineering Internal Radial Clearance](#)

Specifications

Engineering Group Mounted Bearing

Bearing Number 22218

Shaft Size 3 1/4 in

Shaft Size Type Imperial

Full Timken Part Number

- QATP18A304SB
- QATP18A304SC
- QATP18A304SEB
- QATP18A304SEC
- QATP18A304SEM
- QATP18A304SEN
- QATP18A304SEO
- QATP18A304SET
- QATP18A304SM
- QATP18A304SN
- QATP18A304SO



QATP18A304ST

Locking Style Single Concentric**Housing Construction** Top Pull Take-Up**Dimensions****Dimension A1** 4.32 in
109.7 mm**Dimension B** 4.09 in
103.9 mm**Dimension C** 5.13 in
130.2 mm**Dimension D** 9.94 in
252.5 mm**Dimension E** 8.41 in
213.6 mm**Dimension F** 2.41 in
61.3 mm**Dimension G** 3.54 in
90 mm**Dimension H** 4.5 in
114.3 mm**Dimension J** 2.25 in
57.1 mm**Dimension K** 1.44 in
36.5 mm**Dimension L** 9-1/2 in
241.3 mm**Dimension M** 2.59 in
65.9 mm

Dimension N	4.37 in 110.9 mm
Dimension P	9 in 228.6 mm
Dimension Q	1.31 in 33.3 mm
Dimension RA	0.34 in 8.6 mm
Dimension S	1.38 in 35.1 mm
Dimension TA	4.03 in 102.4 mm
Dimension U	0.81 in 20.6 mm

Radial and Thrust Factors

C0 - Static Load	87200 lbf 388000 N
C - Dynamic Load (Basic)	79700 lbf 355000 N
e - Geometry Factor	0.23
Y1 - Geometry Factor	2.90
Y2 - Geometry Factor	4.31

Engineering Seal Speed

Oil Lubrication - M/N Seal	1400 rpm
Oil Lubrication - T Seal	2400 rpm
Oil Lubrication - B/C/O Seal	1000 rpm

Grease Lubrication - M/N Seal	1400 rpm
--------------------------------------	----------

Grease Lubrication - T Seal	2000 rpm
------------------------------------	----------

Grease Lubrication - B/C/O Seal	1000 rpm
--	----------

Engineering Bearing Attributes

Float	0.08 in 2.03 mm
--------------	--------------------

Shaft Tolerance	0.0030 in 0.076 mm
------------------------	-----------------------

Engineering Internal Radial Clearance

Eng Internal Radial Clearance - Min	0.0024
--	--------

Eng Internal Radial Clearance - Max	0.0039
--	--------

Pre Install Clearance Min	0.0024 in 0.060 mm
----------------------------------	-----------------------

Pre Install Clearance Max	0.0039 in 0.100 mm
----------------------------------	-----------------------

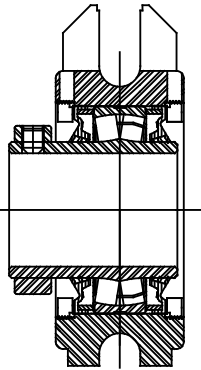
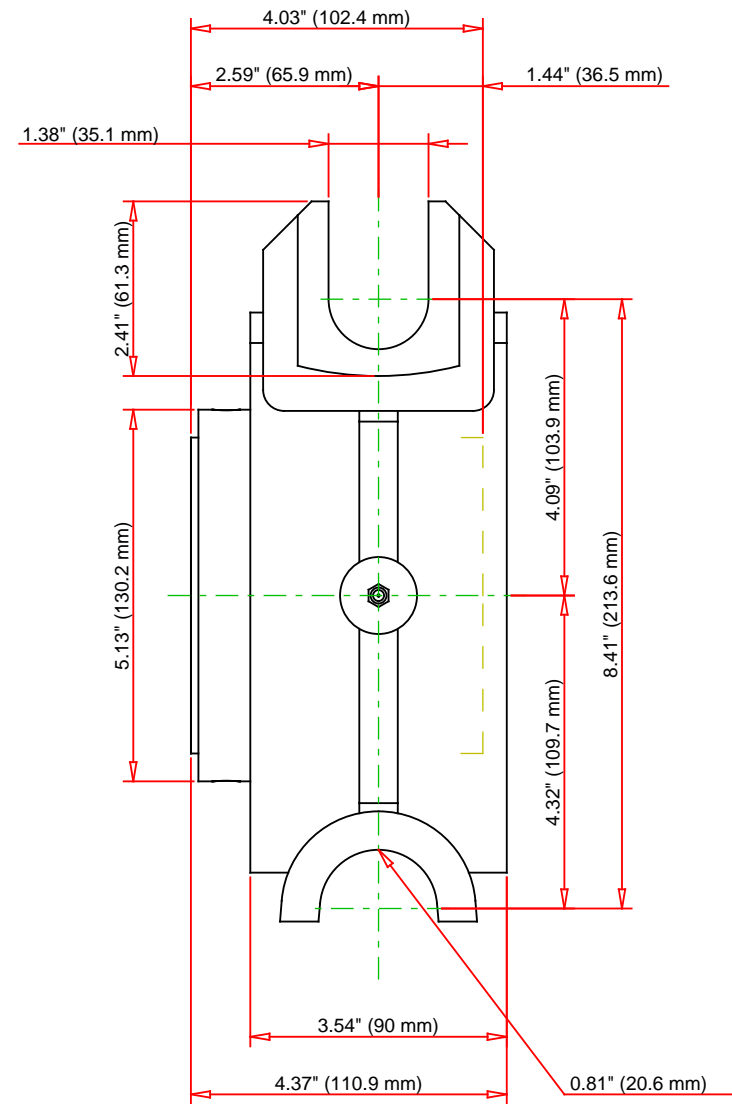
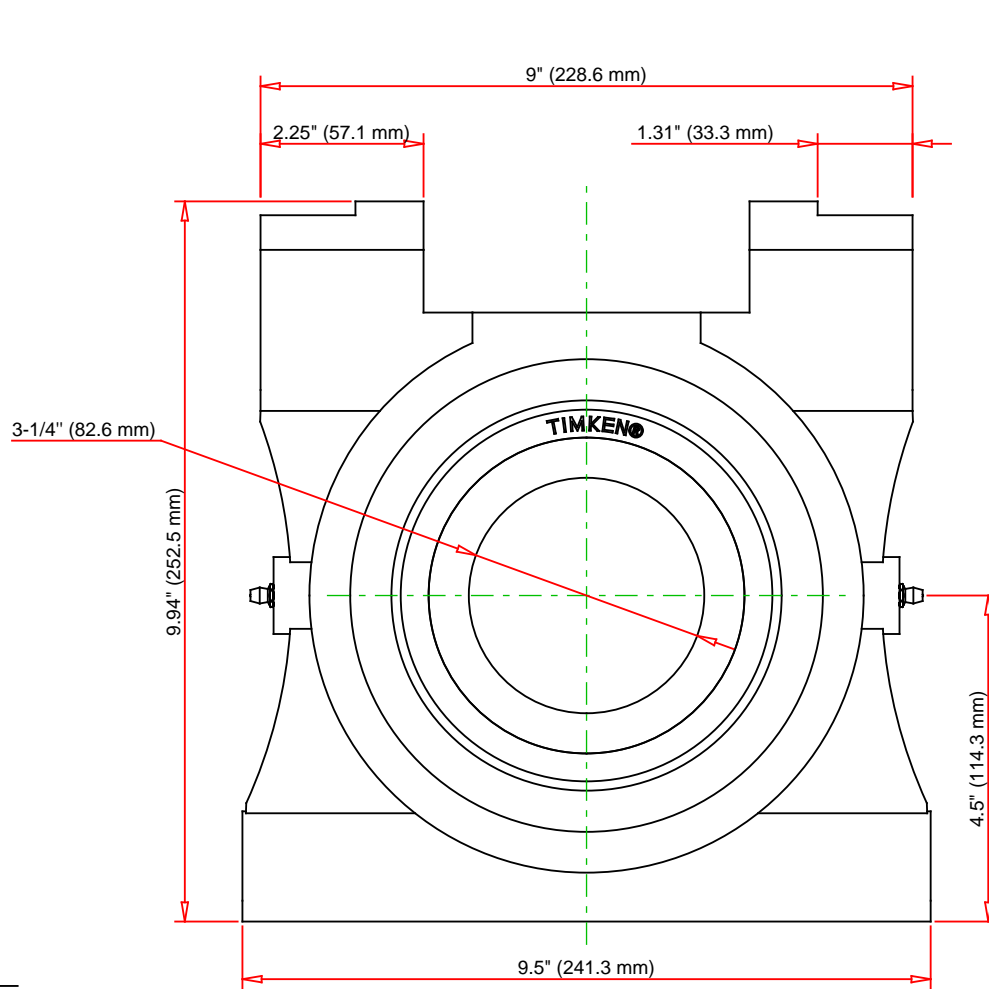

Note: Section View not to Scale

C - Dynamic Load	79700	lbf	355000	N
C0 - Static Load	87200	lbf	388000	N
Weight		lb		kg
Max. Speed T-Seals & Grease	2000	rpm		
Rad. Clearance - Max.	0.0039			

TIMKEN

THE TIMKEN COMPANY
NORTH CANTON, OHIO USA

QATP18A304S

Single Concentric Top Pull Take-Up
Block

Every reasonable effort has been made to ensure the accuracy of the information contained in this writing, but no liability is accepted for errors, omissions or for any other reason.

FOR DISCUSSION ONLY