



The Timken Company

4500 Mt Pleasant St. NW

N. Canton, OH 44720

Phone: (234) 262-3000

E-Mail: CustomerCAD@timken.com • **Web site:** www.timken.com

Part Number QAMC15A211S, Single Concentric Cartridge Block

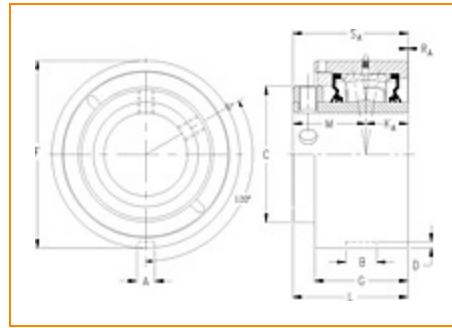

[Specifications](#) | [Dimensions](#) | [Radial and Thrust Factors](#) | [Engineering Seal Speed](#) | [Engineering Bearing Attributes](#) | [Engineering Internal Radial Clearance](#)

Specifications

Engineering Group Mounted Bearing

Bearing Number 22215

Shaft Size 2 11/16 in

Shaft Size Type Imperial

Full Timken Part Number

- QAMC15A211SB
- QAMC15A211SC
- QAMC15A211SEB
- QAMC15A211SEC
- QAMC15A211SEM
- QAMC15A211SEN
- QAMC15A211SEO
- QAMC15A211SET
- QAMC15A211SM
- QAMC15A211SN
- QAMC15A211SO
- QAMC15A211ST



Locking Style	Single Concentric
----------------------	-------------------

Housing Construction	Cartridge
-----------------------------	-----------

UPC Code	0883450303101
	0883450303118
	0883450303125
	0883450303132
	0883450303149
	0883450303156
	0883450303163
	0883450303170
	0883450303187
	0883450303194
	0883450303200
0883450303217	

Dimensions

Dimension A	0.59 in 15 mm
--------------------	------------------

Dimension B	1.03 in 26.2 mm
--------------------	--------------------

Dimension C	4.29 in 109 mm
--------------------	-------------------

Dimension D	0.25 in 6.4 mm
--------------------	-------------------

Dimension F	5 7/8 in 149.2 mm
--------------------	----------------------

Dimension G	3.14 in 79.8 mm
--------------------	--------------------

Dimension KA	1.25 in 31.8 mm
---------------------	--------------------

Dimension L Exp	4.04 in 102.6 mm
------------------------	---------------------

Dimension L Fix	3.96 in 100.6 mm
------------------------	---------------------

Dimension M	2.37 in 60.2 mm
--------------------	--------------------

Dimension RA	0.32 in 8.1 mm
---------------------	-------------------

Dimension SA	3.62 in 91.9 mm
---------------------	--------------------

Radial and Thrust Factors

C0 - Static Load	54100 lbf 240000 N
-------------------------	-----------------------

C - Dynamic Load (Basic)	49900 lbf 222000 N
---------------------------------	-----------------------

e - Geometry Factor	0.22
----------------------------	------

Y1 - Geometry Factor	3.14
-----------------------------	------

Y2 - Geometry Factor	4.67
-----------------------------	------

Engineering Seal Speed

Oil Lubrication - M/N Seal	1600 rpm
-----------------------------------	----------

Oil Lubrication - T Seal	2900 rpm
---------------------------------	----------

Oil Lubrication - B/C/O Seal	1300 rpm
-------------------------------------	----------

Grease Lubrication - M/N Seal	1600 rpm
--------------------------------------	----------

Grease Lubrication - T Seal	2400 rpm
------------------------------------	----------

Grease Lubrication - B/C/O Seal	1300 rpm
--	----------

Engineering Bearing Attributes

Float	0.083 in 2.108 mm
Shaft Tolerance	0.0020 in 0.051 mm

Engineering Internal Radial Clearance

Eng Internal Radial Clearance - Min	0.0020
Eng Internal Radial Clearance - Max	0.0031
Pre Install Clearance Min	0.0020 in 0.050 mm
Pre Install Clearance Max	0.0031 in 0.080 mm

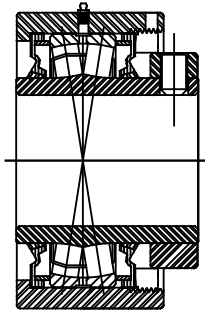
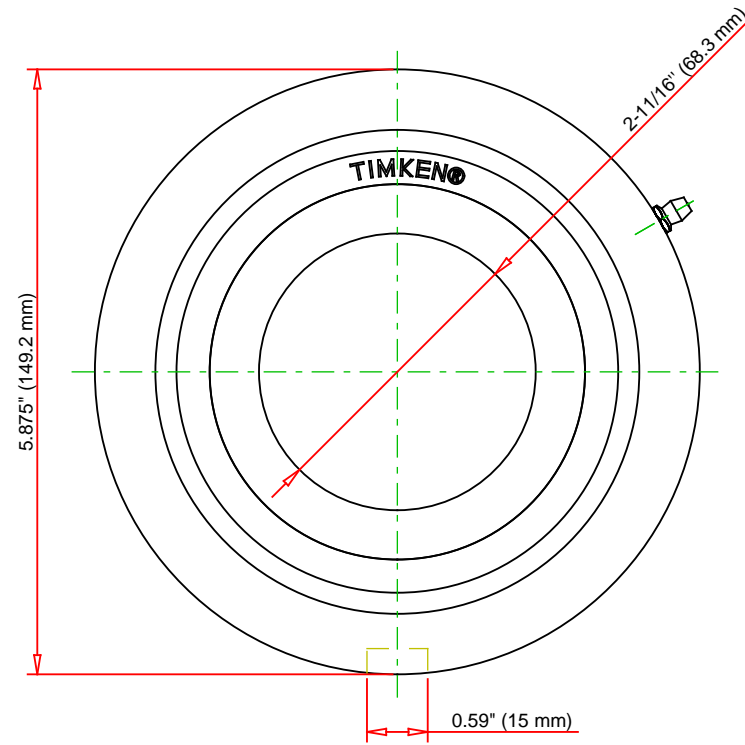
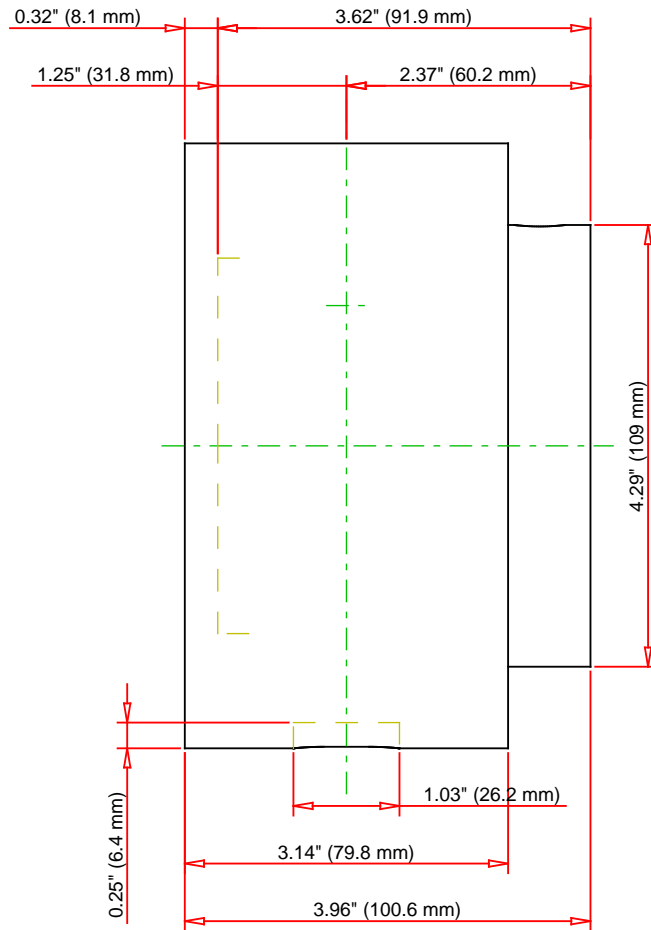

Note: Section View not to Scale

C - Dynamic Load	49900	lbf	222000	N
C0 - Static Load	54100	lbf	240000	N
Weight	18	lb	8.2	kg
Max. Speed T-Seals & Grease	2400	rpm		
Rad. Clearance - Max.	0.0031			

TIMKEN

THE TIMKEN COMPANY
NORTH CANTON, OHIO USA

QAMC15A211S
Single Concentric Cartridge Block

Every reasonable effort has been made to ensure the accuracy of the information contained in this writing, but no liability is accepted for errors, omissions or for any other reason.

FOR DISCUSSION ONLY