



**The Timken Company**

4500 Mt Pleasant St. NW

N. Canton, OH 44720

**Phone:** (234) 262-3000

**E-Mail:** [CustomerCAD@timken.com](mailto:CustomerCAD@timken.com) • **Web site:** [www.timken.com](http://www.timken.com)

## Part Number QAMC15A300S, Single Concentric Cartridge Block

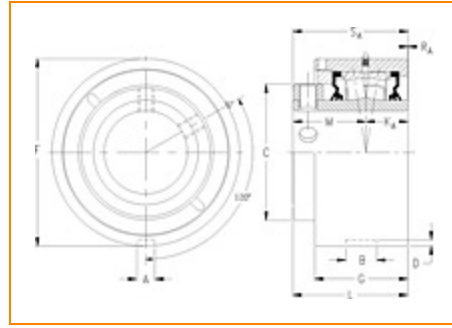

[Specifications](#) | [Dimensions](#) | [Radial and Thrust Factors](#) | [Engineering Seal Speed](#) | [Engineering Bearing Attributes](#) | [Engineering Internal Radial Clearance](#)

### Specifications

**Engineering Group** Mounted Bearing

**Bearing Number** 22215

**Shaft Size** 3 in

**Shaft Size Type** Imperial

**Full Timken Part Number**

- QAMC15A300SB
- QAMC15A300SC
- QAMC15A300SEB
- QAMC15A300SEC
- QAMC15A300SEM
- QAMC15A300SEN
- QAMC15A300SEO
- QAMC15A300SET
- QAMC15A300SM
- QAMC15A300SN
- QAMC15A300SO
- QAMC15A300ST



<b>Locking Style</b>	Single Concentric
----------------------	-------------------

<b>Housing Construction</b>	Cartridge
-----------------------------	-----------

<b>UPC Code</b>	0883450043601
	0883450043618
	0883450043632
	0883450043649
	0883450043656
	0883450043663
	0883450043670
	0883450043687
	0883450194587
	0883450194747
0883450271752	
0883450271912	

## Dimensions

<b>Dimension A</b>	0.59 in 15 mm
--------------------	------------------

<b>Dimension B</b>	1.03 in 26.2 mm
--------------------	--------------------

<b>Dimension C</b>	4.29 in 109 mm
--------------------	-------------------

<b>Dimension D</b>	0.25 in 6.4 mm
--------------------	-------------------

<b>Dimension F</b>	5 7/8 in 149.2 mm
--------------------	----------------------

<b>Dimension G</b>	3.14 in 79.8 mm
--------------------	--------------------

<b>Dimension KA</b>	1.25 in 31.8 mm
---------------------	--------------------

<b>Dimension L Exp</b>	4.04 in 102.6 mm
------------------------	---------------------

<b>Dimension L Fix</b>	3.96 in 100.6 mm
------------------------	---------------------

<b>Dimension M</b>	2.37 in 60.2 mm
--------------------	--------------------

<b>Dimension RA</b>	0.32 in 8.1 mm
---------------------	-------------------

<b>Dimension SA</b>	3.62 in 91.9 mm
---------------------	--------------------

## Radial and Thrust Factors

<b>C0 - Static Load</b>	54100 lbf 240000 N
-------------------------	-----------------------

<b>C - Dynamic Load (Basic)</b>	49900 lbf 222000 N
---------------------------------	-----------------------

<b>e - Geometry Factor</b>	0.22
----------------------------	------

<b>Y1 - Geometry Factor</b>	3.14
-----------------------------	------

<b>Y2 - Geometry Factor</b>	4.67
-----------------------------	------

## Engineering Seal Speed

<b>Oil Lubrication - M/N Seal</b>	1600 rpm
-----------------------------------	----------

<b>Oil Lubrication - T Seal</b>	2900 rpm
---------------------------------	----------

<b>Oil Lubrication - B/C/O Seal</b>	1300 rpm
-------------------------------------	----------

<b>Grease Lubrication - M/N Seal</b>	1600 rpm
--------------------------------------	----------

<b>Grease Lubrication - T Seal</b>	2400 rpm
------------------------------------	----------

<b>Grease Lubrication - B/C/O Seal</b>	1300 rpm
--	----------

## Engineering Bearing Attributes

<b>Float</b>	0.083 in 2.108 mm
--------------	----------------------

<b>Shaft Tolerance</b>	0.0020 in 0.051 mm
------------------------	-----------------------

## Engineering Internal Radial Clearance

<b>Eng Internal Radial Clearance - Min</b>	0.0020
--	--------

<b>Eng Internal Radial Clearance - Max</b>	0.0031
--	--------

<b>Pre Install Clearance Min</b>	0.0020 in 0.050 mm
----------------------------------	-----------------------

<b>Pre Install Clearance Max</b>	0.0031 in 0.080 mm
----------------------------------	-----------------------

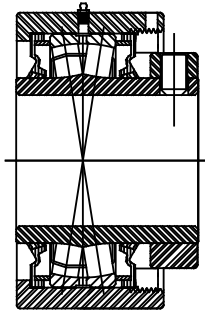
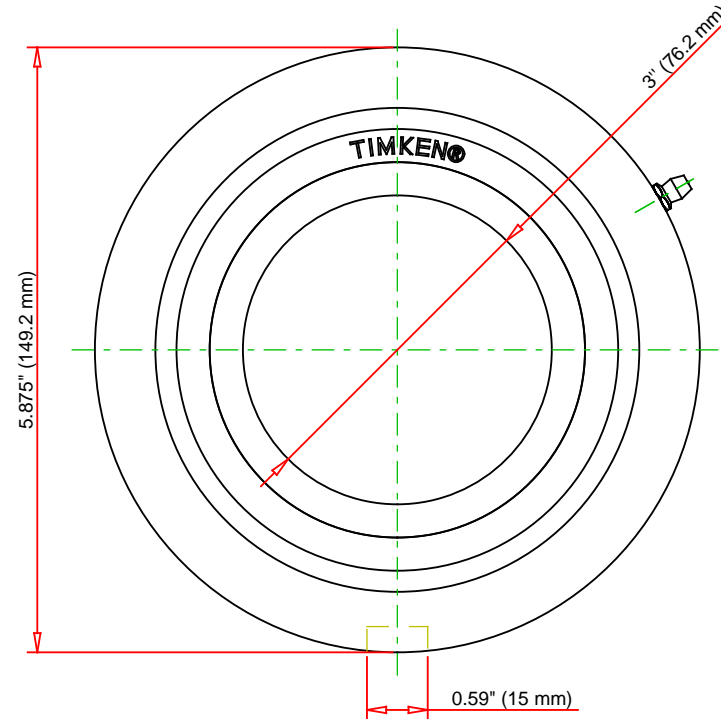
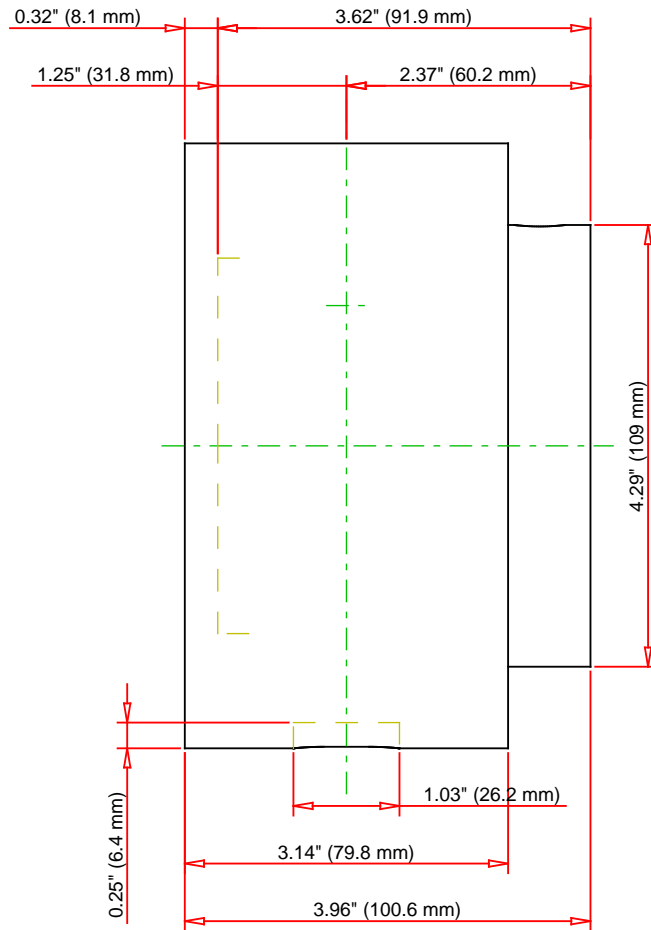

Note: Section View not to Scale

C - Dynamic Load	49900	lbf	222000	N
C0 - Static Load	54100	lbf	240000	N
Weight	18	lb	8.2	kg
Max. Speed T-Seals & Grease	2400	rpm		
Rad. Clearance - Max.	0.0031			

**TIMKEN**

THE TIMKEN COMPANY  
NORTH CANTON, OHIO USA

**QAMC15A300S**  
Single Concentric Cartridge Block

Every reasonable effort has been made to ensure the accuracy of the information contained in this writing, but no liability is accepted for errors, omissions or for any other reason.

**FOR DISCUSSION ONLY**